VPFlowScope M

User manual

© 2025 Van Putten Instruments BV



VPFlowScope M

© 2025 Van Putten Instruments BV

All rights reserved. No parts of this document may be reproduced in any form or by any means - graphic, electronic, or mechanical, including photocopying, recording, taping, or information storage and retrieval systems - without the written permission of the publisher.

Products that are referred to in this document may be either trademarks and/or registered trademarks of the respective owners. The publisher and the author make no claim to these trademarks.

While every precaution has been taken in the preparation of this document, the publisher and the author assume no responsibility for errors or omissions, or for damages resulting from the use of information contained in this document or from the use of programs and source code that may accompany it. In no event shall the publisher and the author be liable for any loss of profit or any other commercial damage caused or alleged to have been caused directly or indirectly by this document.

Last revision date: 04-04-2025 in Delft

Publisher







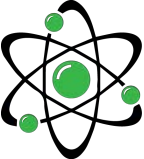

Van Putten Instruments BV
Marlotlaan 1G
2614 GV Delft
The Netherlands

Table of Contents

1 Warning - Read this first	5
2 Introduction	6
3 Product overview	7
1 VPFlowScope M transmitter.....	7
2 VPSensorCartridge	8
3 Safety system	9
4 Configuration	10
4 Quick start	11
5 Measurement	13
1 Flow	13
2 Pressure	13
3 Temperature	13
4 Totalizer	14
6 Mechanical installation	15
1 Installation point	15
2 Piping table	17
3 P35X Cartridges	18
4 P22X Cartridges	21
5 Replacing the VPSensorCartridge.....	23
7 Connectivity & communication	28
1 LEADS	28
2 Analog out	28
4...20mA	28
Pulse	29
Alarm	30
3 RS-485	31
4 Ethernet	31
5 USB	32
6 Display	32
Keypad	32
Main pages	32
Menu	33
7 Data logger	36
8 Modbus	36
1 Register table	37
2 Enumerations	40

9 Electrical connections	42
1 4..20mA	42
2 Pulse	43
3 Alarm	44
4 RS-485	44
5 Ethernet	46
10 VPStudio software	47
11 Exchanging VPSensorCartridges	48
12 Specifications Transmitters	49
13 Specifications VPSensorCartridges	50
14 Order information and accessories	52
1 Transmitter	52
2 VPSensorCartridge	52
3 Accessories	52
15 Energy Monitoring Applications	53
16 Appendix A - Underwriters Laboratories (UL)	54
17 Appendix B - Federal Communications Commission (FCC) Statement	55

1 Warning - Read this first

	<p>Compressed air can be dangerous! Please familiarize yourself with the forces under pressurized conditions. Respect the local guidelines and regulations for working with pressurized equipment.</p>
	<p>Gas flow through pipes follows certain physical laws. These physical laws have serious consequences for the installation requirements. Familiarize yourself with the basic physical laws of flow measurement, to make sure that the product is installed correctly. Always make sure that upstream length, downstream length, flow, pressure, temperature and humidity conditions are within specifications.</p>
	<p>Precision instruments need maintenance. Check your flow meter regularly and make sure it remains clean. When polluted, gently clean the sensor using de-mineralised water or cleaning alcohol.</p>
	<p>Not intended for fiscal metering or billing. Our flow meters are not certified for fiscal metering. Laws on fiscal metering and billing may vary per country or state.</p>
	<p>Do not overestimate the results. VPI instruments does not take any responsibility for the correctness of measurement results under field conditions. The practical measurement uncertainty of a flow meter in the field may vary, depending on how well it is installed, due to the nature of gas flow. The piping table provides guidelines on how to optimize the field accuracy. Our products are not intended to be used as a single means to determine compressor capacity.</p>
	<p>Do not open the device. Our instruments are assembled with high precision. Opening this device is dangerous and may destroy the instrument. Warranty is voided when you open the instrument.</p>
	<p>Different Safety Mechanisms. The safety mechanisms vary based on the cartridge models. Using safety mechanisms designed for one cartridge model on another, or modifying them, is dangerous.</p>
	<p>Prevent possible ground loops. It is recommended to not combine the 24V power supply of this product, a laptop connected with its power supply and the USB cable connection. Use the laptop on battery mode, do not connect the USB cable and 24V power supply of this product at the same time or use an USB isolator in combination with the USB cable.</p>
	<p>Feedback leads to product improvement. Please share your experience with us, as we are continuously improving our products in our commitment to quality, reliability and ease of use. Let us know via sales@vpinstruments.com!</p>

2 Introduction

Congratulations! **You purchased the first on the market and original 4-in-1 flow sensor for compressed air.** With the VPFlowScope M, you can monitor flow, pressure, temperature, and total air consumption, simultaneously. The optional data logger enables you to record all 4 parameters.

With the introduction of the VPFlowScope M, re-calibration becomes history. Unlike traditional flow meters, the VPFlowScope M does not require traditional re-calibration. Instead, the VPFlowScope M consists of a Transmitter and the patented VPSensorCartridge, which reduces re-calibration to a simple exchange.

But there is more to the VPFlowScope M:

- Four in one: flow, pressure, temperature, total flow simultaneously
- Wide measurement range (1:300)
- 2% reading accuracy on flow
- Ultra compact size and low weight
- Optional direction measurement
- Optional display
- Optional data logger

Great products deserve great user manuals. We have done our best to make this user manual as complete as possible. New users, please read it carefully to familiarize yourself with our products. Experienced users can check out the [Quick start chapter](#).

Check the packaging box for any inconsistencies. Should there be any shipping damage, notify the local carrier. At the same time a report should be submitted to Van Putten Instruments BV, Marlotlaan 1G, 2614 GV DELFT, The Netherlands.

This manual is dedicated to:

VPFlowScope M Transmitter: VPM.T001.DXXX, running firmware 3.0 or later

VPFlowScope M VPSensorCartridge: VPM.R150.P35X.PN10

VPFlowScope M VPSensorCartridge: VPM.R150.P22X.PN10

For technical questions or support inquiries, please contact us by email at support@vpinstruments.com.

For latest VPStudio software and overview of latest firmware versions, please visit www.vpinstruments.com.

Older software features may not be covered by the contents of this user manual.

Do you like our products and this user manual? Tell others by sharing your [review](#)! Do you miss something? Let us know via sales@vpinstruments.com!

3 Product overview

3.1 VPFlowScope M transmitter

Meet the Transmitter, the 'brains' of the VPFlowScope M. The Transmitter is one part of the VPFlowScope M which needs to be combined with a VPSensorCartridge and a safety system. The Transmitter features various interfaces as standard: RS-485, Ethernet, USB, analog out. The first three can be used to carry Modbus messages, analog out can be configured to output 4..20mA, pulse and alarm signals. The optional display and data logger offer additional functionality for visualization and logging of measurement data.

The Transmitter is available in 3 configurations to fit every application. The available models are listed in the table below. The Transmitter is to be used with the VPSensorCartridge, of which two versions are available. Inside the VPSensorCartridge are sensors that perform the actual measurement.

When mated to a VPSensorCartridge, the Transmitter can be rotated 360 degrees. This enables you to align the display for every orientation. Loosen the locking ring when rotating the display, fasten it hand-tight when installed.

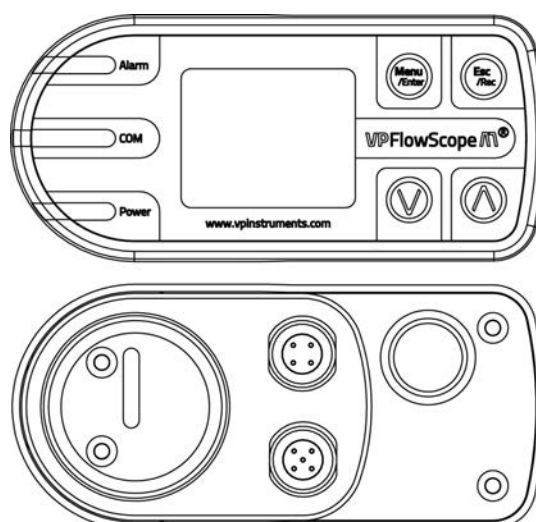

Available Transmitter models

Order Code	4..20mA / Pulse / Alarm	RS-485	USB	Ethernet	Display	Data logger
VPM.T001.D000	✓	✓	✓	✓		
VPM.T001.D010	✓	✓	✓	✓	✓	
VPM.T001.D011	✓	✓	✓	✓	✓	✓

Available models on day of printing

3.2 VPSensorCartridge

The VPSensorCartridge includes all sensors to measure flow, pressure and temperature simultaneously. It also holds its calibration characteristics. This makes it possible to freely exchange the VPSensorCartridge among Transmitters, or to replace it when its calibration has expired.

Every type of VPSensorCartridge can be connected to every model of Transmitter. [See chapter 3.1](#) for all available Transmitters.

The VPSensorCartridge has a flow direction indicator in the shape of an arrow that points in the positive direction. The indicator can be used for proper alignment.

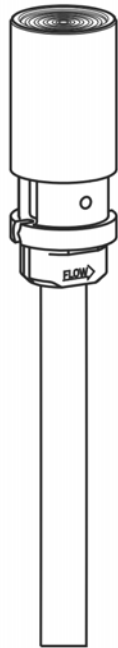

Available VPSensorCartridge models

Order Code	Flow	Temperature	Pressure	Bi-directional
VPM.R150.P350.PN10	✓	✓	✓	
VPM.R150.P351.PN10	✓	✓	✓	✓
VPM.R150.P220.PN16	✓	✓	✓	
VPM.R150.P221.PN16	✓	✓	✓	✓

3.3 Safety system



Installation under pressure can be dangerous. Make sure that you understand the safety system before installing the VPFlowScope M!

The safety system is specially designed for the VPFlowScope M.

• VPM.R150.P35X models

When the VPSensorCartridge is in the compression fitting and the safety cable is attached with the locking ring fully tightened, the probe can never exit the compression fitting due to the matching length of the cable. When the VPSensorCartridge is installed on the right depth, the safety cable can be strained and locked. The complete safety system is tested and certified for safety. Instructions on how to assemble the safety system can be found in [chapter 6 mechanical installation](#).

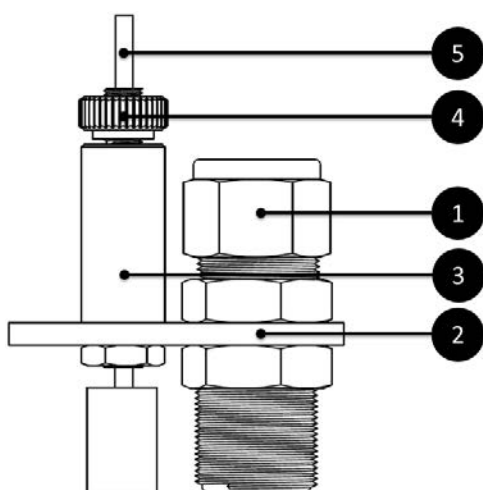

1. **Compression fitting:** 0.5 inch with Teflon ferrule
2. **Safety plate:** Used to connect fitting and safety system
3. **Auto brake:** The safety chain can be slide through the auto brake system. Moving upwards is only possible when the safety lock is pushed downwards
4. **Safety lock:** This nut can be used to lock or unlock the safety release. Push down the lock to release the safety chain
5. **Safety cable:** The safety cable can be attached to the VPSensorCartridge

• VPM.R150.P22X models

VPSensorCartridge is housed within a compression fitting with integrated safety lock, where the probe remains secure thanks to an additional ring. The compression fitting with integrated safety lock is leak proof and ensures the safety. This setup also guarantees easy adjustments for the installation depth. The complete safety system is tested and certified for safety. Test certificate is available upon request.

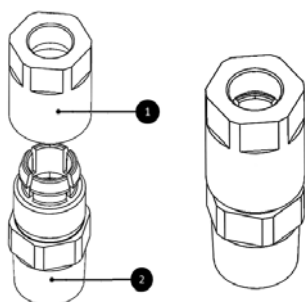

1. **Clamp Nut:** Used to secure the cartridge
2. **Clamp Fitting NPT 1/2"**

3.4 Configuration

The VPFlowScope M needs only one step to be ready for basic operation: It needs to know the exact inner pipe diameter. Setting a wrong inner diameter will lead to very significant misreadings, due to velocity not being properly converted to volumetric units. The pipe diameter can be programmed with the keypad on the Transmitter, by writing the right Modbus register using a Modbus master or with the VPStudio configuration software. VPStudio can be downloaded from our website www.vpinstruments.com.

For P35X models, the minimum programmable diameter is 25 mm | 0.98" and the maximum is 1016 mm | 40".

For P22X models, the minimum programmable diameter is 22 mm | 0.87" and the maximum is 115 mm | 4.5".

4 Quick start

This chapter contains the basic steps to start using your VPFlowScope M. Additional information on all subjects can be found in the next chapters.

1. Unpack

Unpack the box and check if all items are there and in good shape.

2. Apply power

Connect the unit to a DC power source (14..24 VDC). See [chapter 9 electrical connections](#).

3. Mechanical installation

- Find the best point of installation for this product. Make sure that the process conditions are within the specifications of the flow meter and the upstream and downstream straight pipe lengths are respected
- For installation of the VPFlowScope M, an insertion point needs to be created. A socket with internal 1/2 inch thread is required
- A ball valve with a minimum size of DN15 full bore, female BSP or NPT process connection should be in place
- Assemble the VPFlowScope M including safety system and mount it on top of the ball valve
- Open the valve and insert the probe
- The sensor needs to be in the middle of the pipe for diameters larger than 2.5 inch. [See chapter 6.1 installation point](#)
- Tighten the compression fitting nut according to instruction
- Pull on the safety chain for P35X cartridge to strain it and turn the safety lock clockwise to lock it [See chapter 6 mechanical installation](#) for more detailed information

4. Electrical installation

4.1 Permanent installation

Connect a cable with 5 Pin M12 connector to the Transmitter. The cable can be connected to VPVision, a central data acquisition / building management system or data logger via Modbus RTU (RS-485), 4..20mA or Pulse. In addition to RS-485, analog out, a 4 Pin M12 connector is available exposing an Ethernet interface, which can be used for Modbus TCP.

Apply 14..24 VDC to power up the device. Use a Class II power supply (less than 2 Amps). If a display is present, it will light up when power is applied.

4.2 Temporary installation

Use a 24 Volt power supply with M12 connector to power the device.

[See chapter 9 electrical connections](#) for more information.

5. Configure the Transmitter

For correct measurement, the diameter should be programmed into the instrument.

- The quickest way: Program the inner pipe diameter using the display and buttons
- Alternative method: Diameter can also be programmed using Modbus RTU (RS-485, USB) or Modbus TCP (Ethernet). If one is inexperienced using Modbus, the VPStudio software suite can do the exact same thing any other Modbus master can, but wrapped in a user-friendly graphical interface
- Advanced settings: Configure Ethernet/IP address, 4..20mA/Pulse/Alarm boundaries, device date/time using display, Modbus or VPStudio

6. Data recording

VPFlowScope M models featuring the data logger option are equipped with a circular memory, designed to hold one year of data. Whenever the device is active, this memory is being written to. The data logger expects date and time of the device to be set to UTC. Once date and time has been set, the device can go at least 5 days without power while retaining the configured date and time. If the device has been without power for more than 5 days, its internal clock may have been reset due to running out of power.

Incorrectly setting date and time, not configuring date and time, not restoring date and time after extended (over 5 days) loss of power may result in data loss due to important data in the circular memory being overwritten!

All retrieval of data is done using standard Modbus messages, which can be transported equally well over RS-485, USB or Ethernet.

5 Measurement

For all parameters the update interval is 1 second. Within this second, multiple samples are taken and averaged to provide a stable and reliable output.

5.1 Flow

The VPSensorCartridge uses our proprietary insertion type thermal mass flow sensor. There is no bypass flow, which results in a high robustness and less sensitivity for dirt or particles. The flow sensor is directly temperature compensated. The flow reading is under normalized conditions (DIN 1343).

The sensor response signal is directly related to the mass flow rate and can be described by the following formula:

$$\text{Flow} = k \cdot \rho \cdot v \cdot (T_s - T_g)$$

k = sensor (geometrical) constant
 ρ = thermal conductivity of the gas
 ρ = density of the gas
 v = actual velocity in m / sec
 T_s = sensor temperature
 T_g = gas temperature

The optional bi-directional sensitivity is shown in the picture on the right. In bi-directional mode the negative flow value will show up with a minus sign.

No flow
Everything in balance.

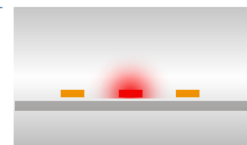

Flow from left
The left part is cooled down; the right part of the bridge is heated up.

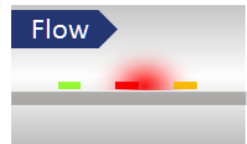

Flow from right
Vice versa! Now the left part is heated up and the right part is cooled down.

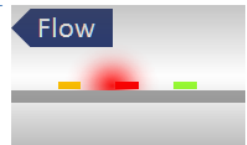

5.2 Pressure

The VPSensorCartridge features a built-in gauge pressure sensor. See your specific VPSensorCartridge specifications for details. The pressure sensor membrane can handle media which are compatible with glass, silicon, stainless steel, Sn/Ni, plating and Au/Ag solder. The sensor signal is sampled with 16 bits. The practical resolution is 5.25 mbar, which is equal to 0.076 psi.

5.3 Temperature

The built in temperature sensor measures the compressed air / gas temperature. At low velocities between zero and 10 m_n/sec, the temperature sensor may heat up itself due to the heated flow sensor element. This will result in higher read out for temperature.

Temperature compensation effects: The flow sensor is compensated dynamically for changes in gas temperature. When exposed to quick temperature changes or large temperature changes (for example taking the unit from outdoor to indoor during winter time, or when mounted downstream of a heat regenerated drier) the temperature compensation may lag behind, which may result in significant measurement errors.

5.4 Totalizer

The totalizer keeps track of the total amount of gas having passed the sensor, which can be displayed on screen in various metric and imperial units. The totalizer value is also available over Modbus. It can be fetched expressed in normalized cubic meters and 1000's of standard cubic feet. All totalizer values are updated with an interval of one second. The totalizer value is written to internal memory every 15 minutes: In the event power cuts out, at most 15 minutes of totalizer accounting is lost.

In effect, the Transmitter features as much as 3 totalizers: Totalizer in the negative direction, totalizer in the positive direction and a combined (sum) totalizer value. The device display only shows the combined (sum) value, which is as mentioned before also available over Modbus. Values for the individual positive and negative direction however are only available as Modbus registers.

[See chapter 8](#) for Modbus registers.

The VPFlowScope M totalizer will reset to zero once the combined (sum) value hits 99,000,000.00 normalized cubic meters. When this value is hit, the combined (sum) value will reset to zero, whilst reducing the positive and negative portion in equal measure.

The totalizer can also be manually reset, which will clear the negative direction, positive direction and combined (sum) value. The reset operation can be carried out by writing to a specific Modbus register, using the device on-display menu and using VPStudio. Setting arbitrary totalizer values is not possible.

6 Mechanical installation

6.1 Installation point

The installation point is crucial for a correct measurement. Sources of error can be: Imprecise installation, uneven flow profiles, swirls, rapid pressure or temperature swings, humidity variation, flow oscillations, sensor contamination and many others. To ensure the highest possible accuracy of flow measurement, installation and piping instructions must be followed. Read this paragraph carefully!

Take into account:

- Choose a location which is accessible, which allows access for wiring and maintenance activities
- Stay within specifications for the VPFlowScope M: when specifications are exceeded, for instance excessive pressure or temperature, inaccurate flow measurement and possible sensor damage are to be expected
- The VPFlowScope M is a precision instrument not designed for mechanical stress. Neither when in operation or during its installation

Avoid:

- Excessive heat; check the temperature specifications
- Potential water damage on the outside. Avoid areas of high humidity and avoid dripping. Be aware that the VPFlowScope M is not watertight, Always use the product with a protective cover when using it outdoors.
- Corrosive atmosphere
- Electrical overloading (voltage spikes, EMF)
- Mechanical stress or vibrations (power tools, hammers, foot bridges, fork lift trucks)
- Harsh environmental influences

	<p>Stop: These devices are only for use with air, nitrogen and other non hazardous and non combustible gases. The maximum working pressure must be respected.</p> <p>P35X models:0...10 bar 0...145 psi gage P22X models:0...16 bar 0...250 psi gage</p>
---	--

Prepare the installation

The VPFlowScope M can be inserted through a tap with 1/2 inch female thread. For installation under pressurized conditions a hot tap saddle can be used.

Use a DN15 full bore ball valve to enable inserting and retracting the VPFlowScope M VPSensorCartridge.

	<p>Warning: Make sure the hole is at least 17 mm (0.67 inch), and completely clear for insertion. Forcefully inserting the VPSensorCartridge will damage it and consequentially incorrect readings or no reading at all</p>
---	---

Installation procedure

Insertion depth

Generally the insertion depth of the VPFlowScope M is 0.5 times the inner pipe diameter, where the bottom of the sensor tip must be in the middle of the pipe (see picture).

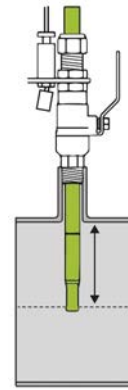

Position

Install the VPFlowScope M upwards in an angle between 1 and 2 o'clock (see picture). Never install the instruments upside down.

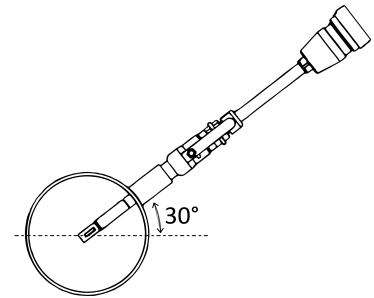

The VPSensorCartridge has a flow direction indicator, this also indicates the alignment of the instrument. A second indicator can be found on the safety system. Make sure it points in the right flow direction. Alignment “by the eye” is sufficient.



Info: A ruler can be used to align the instrument. It can be placed on the flat area where the direction indicator is located.

Exception

Between pipe sizes of 1” and 2” : be aware that the field accuracy level of VPM.R150.P35X models is 10% as the installation errors are bigger.

VPM.R150.P22X models are recommended for diameters smaller than 80 mm.

The insertion depth between DN25 and DN65 is also different. The VPFlowScope M probe has to be inserted almost completely to the bottom of the pipe or else the temperature sensor of the VPFlowScope M probe itself is outside the flow path. The sensor tip will not be in the middle of the pipe any more. The measurement value is automatically corrected for small diameters.

For pipe sizes larger than 65 mm | 2.5 inch, the probe tip should be in the centre of the pipe.

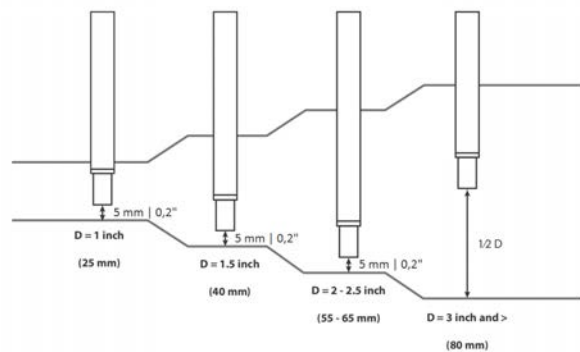

6.2 Piping table



Check the piping table below and match it for your application. The table shows the amount of upstream and downstream length depending on the installation. If applicable in front of the meter, use given upstream length. If applicable in behind the meter, use given downstream length. Gas flow in pipes follows certain rules, which must be observed for optimal measurement results. In some cases the upstream length needs to be longer, in other cases it can be shorter.



If possible, you can always choose a longer upstream length, as these are minimum values. The up- and downstream lengths are used industry wide as guidelines, but will never be a guarantee for obtaining the “true value”.

Piping table

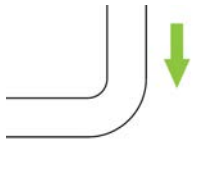
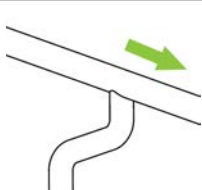
The following table provides a guideline for proper distances between upstream or downstream objects and the VPFlowScope M. The upstream length is the length between the last non-straight object and the VPFlowScope M. If the upstream length is straight, and the distortion is downstream of the VPFlowScope M, you can use the column "downstream length" as a guideline. In very complex situations, with multiple up- and downstream objects, you should consider another location. This table is a practical guideline and is not exact science. Practical situations can have multiple sources of distortion, therefore VPInstruments does not take any responsibility for the correctness.

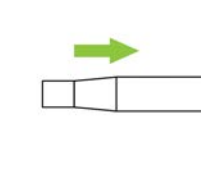
Picture	Description	Upstream length ²	Downstream length ²	Effect
	Single elbow	$30 * D^1$	$10 * D^1$	Distorted flow profile
	Complex feed-in situation (header)	$40 * D^1$	$10 * D^1$	Flow profile will be distorted
	Double elbow, multiple elbows following each other	$40 * D^1$	$10 * D^1$	Distorted profile + swirl
	Diameter change from small to large (gradual or instant)	$40 * D^1$	$5 * D^1$	Jet shaped flow

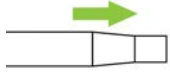
	Diameter change from large to small (gradual change, between 7 and 15 degrees)	$10 * D^1$	$5 * D^1$	Flattened flow profile
---	--	------------	-----------	------------------------

1 = inner diameter; 2 = minimum length

6.3 P35X Cartridges

1. Safety System:

See chapter 3.3 safety system, for all safety system parts.

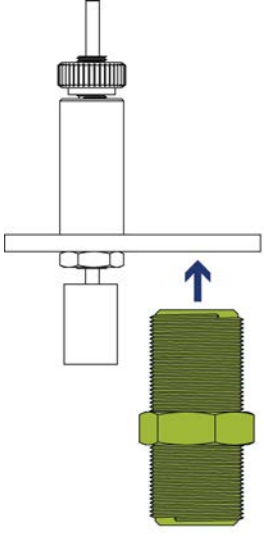
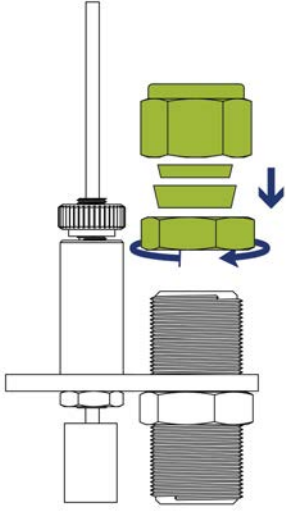
VPM.R150.P35X	
	
<p>Step 1.</p> <ol style="list-style-type: none"> 1. Remove the compression fitting's parts on the long threaded end side 2. Place the safety plate over the compression fitting long threaded end 	<p>Step 2.</p> <ol style="list-style-type: none"> 1. Mount the nut, and close tight. Then mount the compression fitting's tefflon rings and nut

2. Assembling and installing the instrument:





STOP

SAFETY FIRST: START WITH MOUNTING THE SAFETY LINE!

The VPFlowScope M is mounted with a 1/2 inch compression fitting. The probe is sealed with a Teflon ferrule instead of a stainless steel ferrule. Teflon may become slippery. The safety line will keep the sensor secure when it accidentally moves out of the compression fitting. NEVER over-tight the compression fitting, because it might damage the probe.

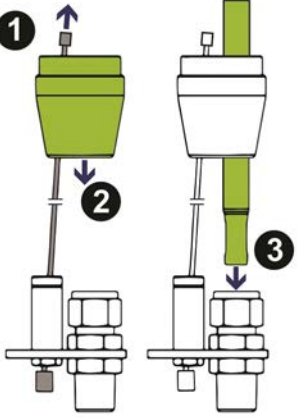
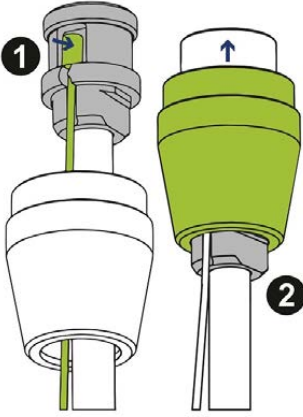
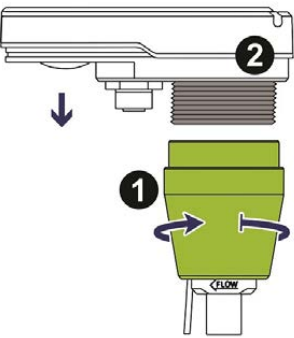
- When the compression fitting is used in accordance with the instructions, the maximum torque needed is 1 Nm.
- In extreme situations, the maximum torque can be increased to 2.5 Nm. Apply this higher torque level only when necessary.

VPM.R150.P35X	
	
<p>Step 1</p> <ol style="list-style-type: none"> 1. Lift the safety cable 2. Slide the locking ring over the safety cable 3. Place the VPSensorCartridge through the locking ring into the compression fitting 	<p>Step 2</p> <ol style="list-style-type: none"> 1. Mount the safety line to the VPSensorCartridge, it should snap in completely 2. Move the locking ring upwards over the VPSensorCartridge and hold it in place
	
<p>Step 3</p> <ol style="list-style-type: none"> 1. Place the Transmitter on top of the assembly 2. Align the probe with the display (default position, arrow should point to the left as on the picture). Tighten the locking ring completely 	<p>Step 4</p> <p>The assembly should look like this. Check if the safety line is secured</p>

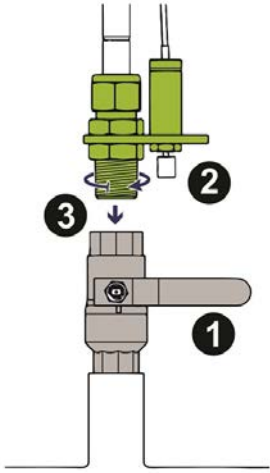
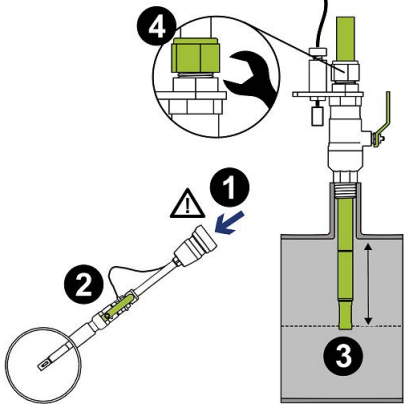
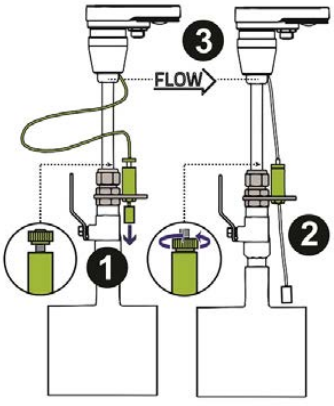
	
<p>Step 5</p> <ol style="list-style-type: none"> 1. Keep the ball valve closed, the probe remains in the compression fitting 2. Check if the safety system is locked 3. Mount the VPFlowScope M including safety system on the ball valve 	<p>Step 6</p> <ol style="list-style-type: none"> 1. Keep your hand on top of the Transmitter ⚠ When you install the VPFlowScope M assembly into a pressurized system you are about to experience temporary leakage around the compression fitting and force trying to push out the VPFlowScope M probe from the compression fitting. When the safety system is correctly installed this is part of the normal installation procedure. 2. Open the ball valve slowly and push the VPFlowScope M probe gently downwards. 3. The probe tip should be in the centre of the pipe 4. Hand-tighten the compression fitting initially to securely position it. After hand-tightening, use a wrench to tighten the fitting an additional 1/2 turn
	
<p>Step 7</p> <ol style="list-style-type: none"> 1. Unscrew the safety lock and pull the safety line tight 2. Tighten the safety lock 3. Align the flow direction. Alignment by the eye is sufficient 	

6.4 P22X Cartridges

1. Safety System:

See chapter 3.3 safety system, for all safety system parts.

VPM.R150.P22X

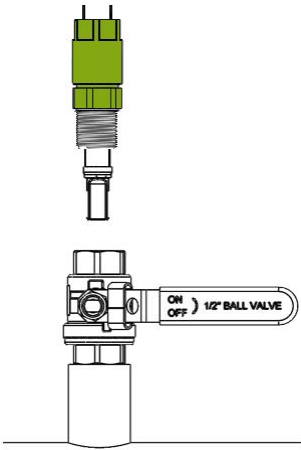

A compression fitting with integrated safety lock is used.
* Test certificate is available upon request.

2. Assembling and installing the instrument:

STOP **SAFETY FIRST: START WITH MOUNTING THE SAFETY LINE!**

The VPFlowScope M is mounted with a 1/2 inch compression fitting. The safety mechanism will keep the sensor secure when it accidentally moves out of the compression fitting.

NEVER over-tight the compression fitting, because it might damage the probe.

- When the compression fitting is used in accordance with the instructions, the torque needed is between 15 to 25 Nm.
- In extreme situations, the maximum torque can be increased to 25 Nm. Apply this higher torque level only when necessary.

VPM.R150.P22X

<p>Step 1</p> <ol style="list-style-type: none"> 1. Keep the ball valve closed, the probe remains in the compression fitting with integrated safety lock 2. Mount the compression fitting with integrated safety lock on the ball valve 	<p>Step 2</p> <ol style="list-style-type: none"> 1. Place the Transmitter on the cartridge 2. Align the probe with the display (default position, arrow should point to the left as on the picture). Tighten the locking ring completely
--	---

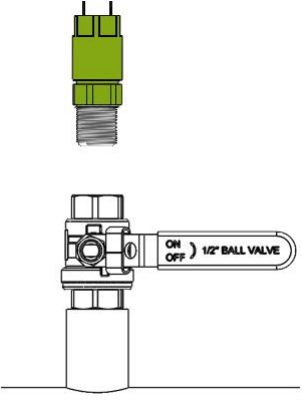
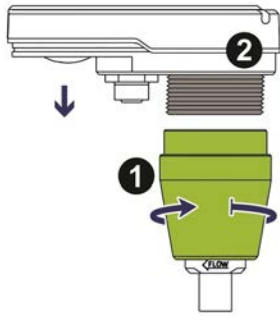
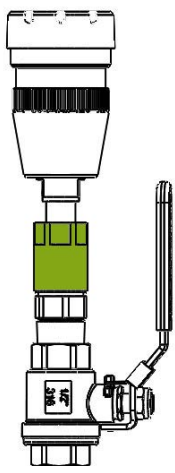
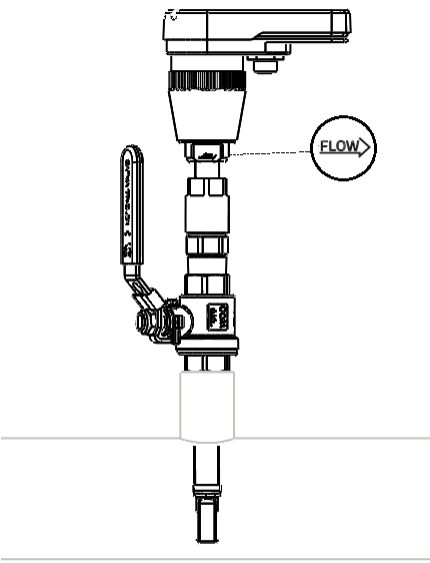
 <p>The diagram shows a green transmitter probe and a ball valve. The ball valve handle is labeled 'ON OFF' and '1/2" BALL VALVE'.</p>	 <p>The diagram shows the transmitter being inserted into the ball valve. A downward arrow is labeled '2', and a circular arrow around the transmitter is labeled '1'.</p>
<p>Step 3</p> <ol style="list-style-type: none"> 1. Keep your hand on top of the Transmitter 2. Open the ball valve slowly and push the VPFlowScope M probe gently downwards. 3. The probe tip should be positioned 5 mm away from the end of the pipe. 4. Align the flow direction. Alignment by the eye is sufficient 5. Hand-tighten the clamp nut. After hand-tightening, use a wrench to tighten. 	<p>Step 4</p> <p>The final assembly should look like this.</p>
 <p>The diagram shows the transmitter and ball valve assembly. The transmitter is green and the ball valve is white.</p>	 <p>The diagram shows the final assembly. A circular arrow labeled 'FLOW' indicates the direction of flow.</p>

6.5 Replacing the VPSensorCartridge

When a VPSensorCartridgeVPM.R150.P35X model needs to be replaced, there is no need to remove the complete assembly. The safety system can be left in place.

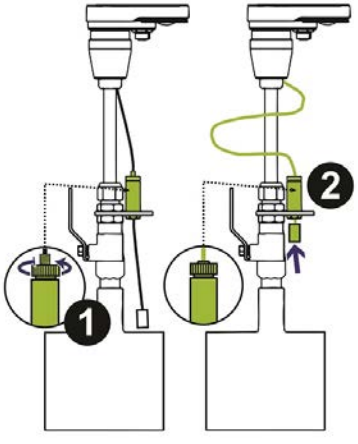
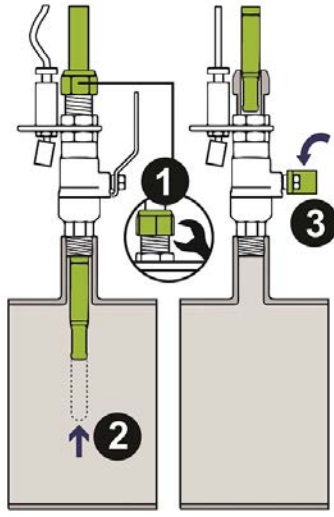
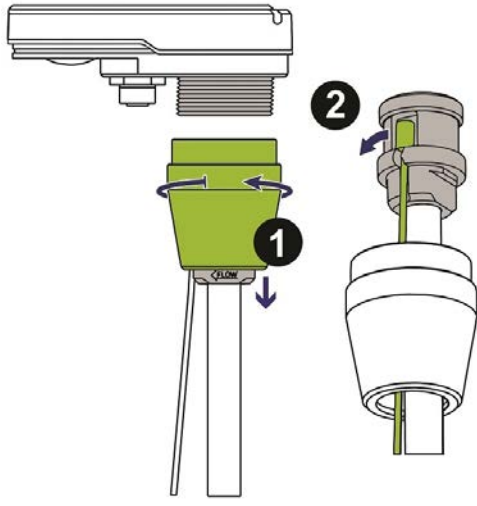
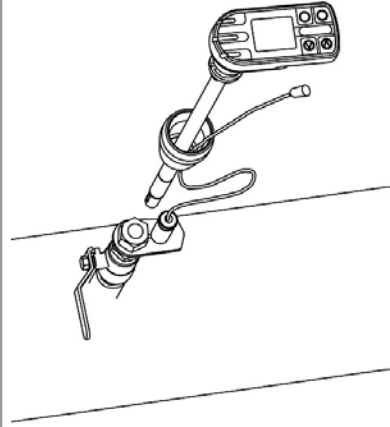
VPM.R150.P35X	
	
<p>Step 1</p> <ol style="list-style-type: none"> 1. Unscrew the safety lock 2. Push the safety lock downwards and lift the safety line until it reaches the end stop 	<p>Step 2</p> <ol style="list-style-type: none"> 1. Apply pressure by hand on top of the Transmitter to prevent the VPFlowScope M to pop upward uncontrolled. Then slowly loosen the compression fitting 2. Lift the probe gently, until the safety chain is completely strained 3. Close the ball valve
	
<p>Step 3</p> <ol style="list-style-type: none"> 1. Unscrew the locking ring and slide it downwards 2. Put the Transmitter aside 3. Remove the safety cable from the VPSensorCartridge 	<p>Step 4</p> <ol style="list-style-type: none"> 1. Replace the VPSensorCartridge

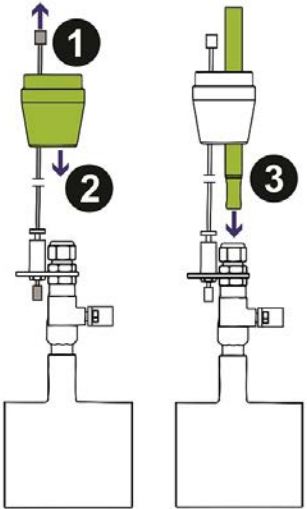
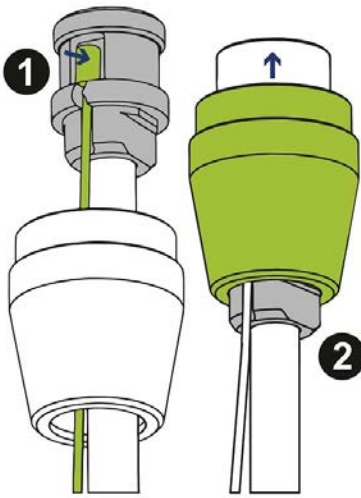
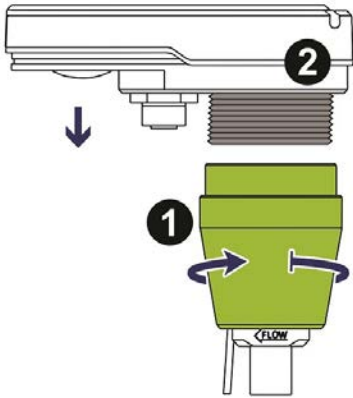
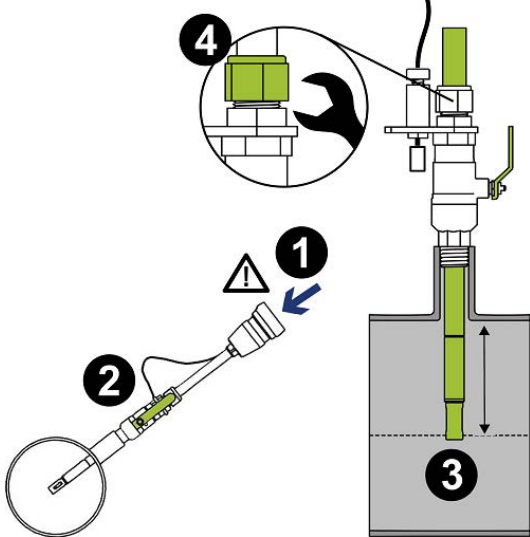
	
<p>Step 5</p> <ol style="list-style-type: none"> 1. Place the new VPSensorCartridge through the locking ring into the compression fitting 	<p>Step 6</p> <ol style="list-style-type: none"> 1. Mount the safety line to the VPSensorCartridge 2. Move the locking ring upwards over the VPSensorCartridge
	
<p>Step 7</p> <ol style="list-style-type: none"> 1. Place the Transmitter on top of the assembly 2. Align the Transmitter in the preferred position 3. Tighten the locking ring completely 	<p>Step 8</p> <ol style="list-style-type: none"> 1. Keep your hand on top of the Transmitter ⚠ When you install the VPFloScope M assembly into a pressurized system you are about to experience temporary leakage around the compression fitting and force trying to push out the VPFloScope M probe from the compression fitting. When the safety system is correctly installed this is part of the normal installation procedure. 2. Open the ball valve slowly and push the VPFloScope M probe gently downwards. 3. The probe tip should be in the centre of the pipe

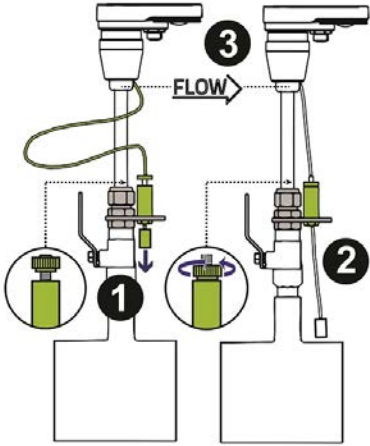
	<p>4. Hand-tighten the compression fitting initially to securely position it. After hand-tightening, use a wrench to tighten the fitting an additional 1/2 turn</p>
	
<p>Step 9</p> <ol style="list-style-type: none">1. Loosen the safety lock and pull the safety line tight2. Tighten the safety lock3. Align the flow direction. Alignment by the eye is sufficient	

When a VPSensorCartridgeVPM.R150.P22X model needs to be replaced, the complete assembly should be removed. The safety system is attached to the cartridge.

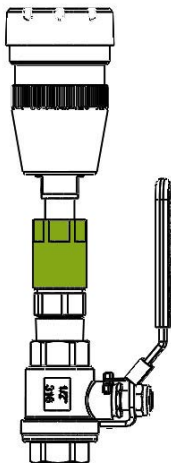
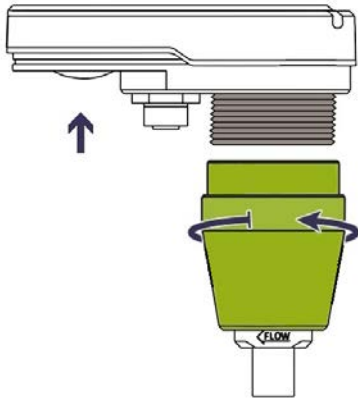
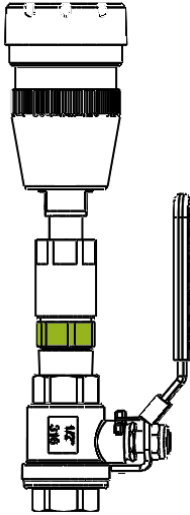
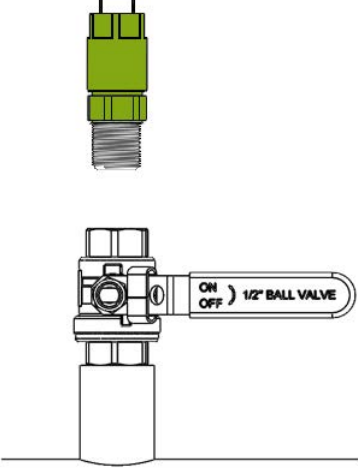
VPM.R150.P22X	
<p>Step 1</p> <ol style="list-style-type: none"> 1. Loosen the clamp nut 2. Apply pressure by hand on top of the Transmitter 	<p>Step 2</p> <ol style="list-style-type: none"> 1. Unscrew the locking ring and slide it downwards 2. Put the Transmitter aside
	
<p>Step 3</p> <ol style="list-style-type: none"> 1. Unscrew the compression fitting with integrated safety lock and take out the cartridge completely. 	<p>Step 4</p> <ol style="list-style-type: none"> 1. Keep the ball valve closed, the new probe remains in the compression fitting with integrated safety lock 2. Mount the new compression fitting with integrated safety lock on the ball valve
	
<p>Step 5</p>	<p>Step 6</p>

1. Place the Transmitter on the cartridge
2. Align the probe with the display (default position, arrow should point to the left as on the picture).

Tighten the locking ring completely

1. Keep your hand on top of the Transmitter
2. Open the ball valve slowly and push the VPFlowScope M probe gently downwards.
3. The probe tip should be positioned 5 mm away from the end of the pipe.
4. Align the flow direction. Alignment by the eye is sufficient
5. Hand-tighten the clamp nut. After hand-tightening, use a wrench to tighten

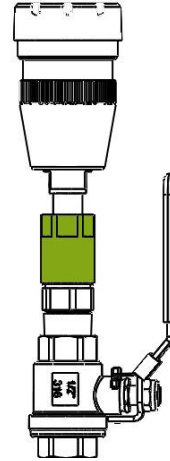
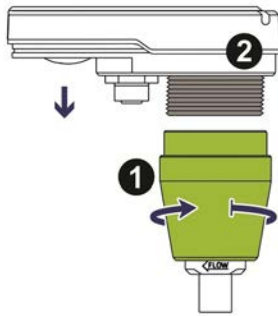

Step 7

The final assembly should look like this.

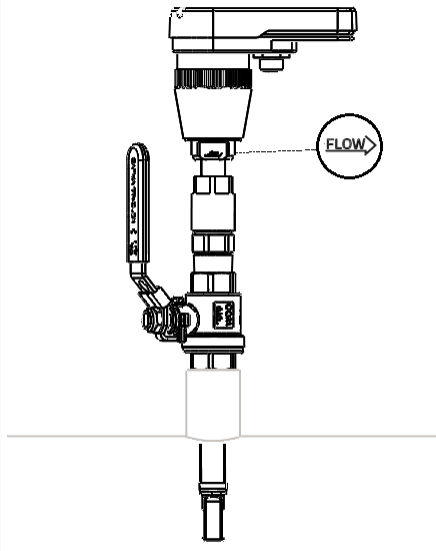

7 Connectivity & communication

The VPFlowScope M Transmitter features various interfaces which enable connecting it to for example VPVision, a central data acquisition system, building management systems, PLC's and many others. This chapter provides information on all available options.

7.1 LEDS

The VPFlowScope M Transmitter has 3 LED's for indicating the status of the instrument. Various colors and patterns can be displayed using these 3 LED's:

Color	Patterns	Descriptions
Green	Blinking at 2 seconds interval	The Transmitter is waiting for a VPSensorCartridge
Green	On	VPSensorCartridge detected and ready for operation
Orange	Blinking fast	RS-485 or USB communication
Red	On	Active alarm
Red	Blinking at 1 seconds interval	Error in VPSensorCartridge: See display and VPStudio
Red	Blinking once	Error in RS-485 or USB communication

In case of an unrecoverable error, contact your local distributor.

7.2 Analog out

The VPFlowScope M Transmitter features an analog output, which can be used in 3 modes: 4..20mA, Pulse, Alarm. Only one mode can be active at any given time. It is possible to change the analog settings via VPStudio 4 or the display.

7.2.1 4..20mA

By selecting the 4..20mA mode for analog out, the analog out interface on the VPFlowScope M Transmitter becomes an active current loop as means of signal transfer. This enables connecting the VPFlowScope M Transmitter to any 4..20mA based system for use in process control, data acquisition, logging or monitoring. Any common multimeter can be inserted into the loop as means for visualizing the signal.

There is one 4..20mA output available on the Transmitter. This output can be assigned to one of the measurement parameters. For ease of configuration, each measurand can be set expressed in a number of units, both SI units and Imperial units.

Measurand	Unit
Velocity	m_n/sec
Velocity	sfps
Flow	m^3_n/hr
Flow	m^3_n/min
Flow	m^3_n/sec
Flow	l_n/min

Flow	l_n /sec
Flow	SCFM
Pressure	bar, mbar (g)
Pressure	psi (g)
Pressure	Pascal (g)
Temperature	°C
Temperature	°F
Temperature	K

All flow and velocity units are under normalized conditions (DIN 1343), this can be changed using Modbus register, display, or VPStudio

The factory default is m_n /sec.

Configuring the 4..20mA output involves selecting a unit, which by extension thereof selects a measurand: Setting a flow unit automatically means flow is selected as measurand for signal transfer.

When a unit has been chosen, one has to decide what value should be represented by 4mA current over the loop, and what value should be represented by 20mA current over the loop. By setting these boundaries as 'analog min' and 'analog max', a scale is created. The 4..20mA output will create a current proportional to where on the set scale the measurand value (expressed in the selected unit) is.

To set analog min, analog max, analog unit and analog mode using a Modbus master, [see chapter 9](#) for Modbus registers.

By configuring a scale, 4mA representing the lowest end of the scale and 20mA the highest end on the scale, the range of the instrument itself is not adjusted! The configured scale or range only affects the analog out interface. All other interfaces, including the display, are unaffected.

Example scales

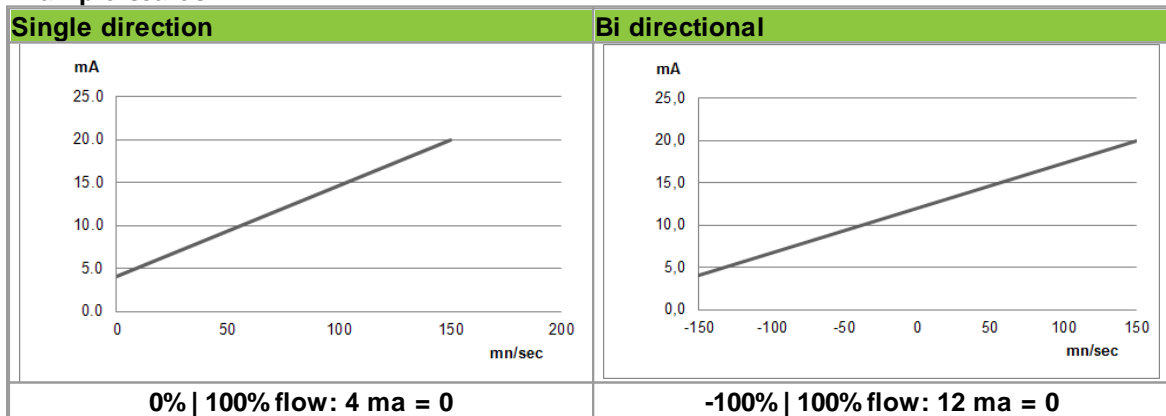

7.2.2 Pulse

By selecting the Pulse mode for analog out, the analog out interface on the VPFlowScope M Transmitter becomes a low-frequency active pulse output. The analog out interface is a 'non potential' free output as it acts like an active current loop. To make it passive, an external third party isolator can be used.

The pulse interval can be set using the device display and buttons, Modbus or VPStudio software. By setting 'analog min', the amount of volume per pulse is configured. The generated pulse provides 20mA at most and has the same voltage as the wire used to power the device. The maximum pulse

frequency is once per 2 seconds. If the measured flow exceeds half the volume set as 'analog min', effectively there will be no pulse as the output is at logical high continuously. To set analog min, analog unit and analog mode using a Modbus master, [see chapter 8](#) for Modbus registers. Analog unit has to be set to a volumetric unit.

The pulse output is tied to the combined (sum) totalizer value. When the totalizer has increased by the programmed pulse interval, the pulse will be generated. As it is not possible to generate a negative pulse, negative flow can not be signaled in Pulse mode. In case of negative flow, the internal totalizer will count backwards. Pulses will not be generated until the same amount of positive flow has been added to the totalizer, canceling out the negative flow.

Pulse output

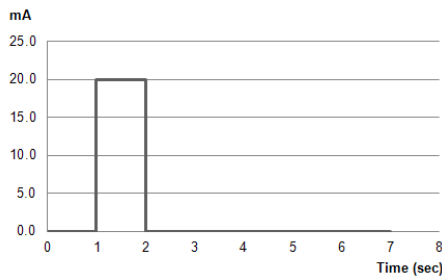

7.2.3 Alarm

By selecting the Alarm mode for analog out, the analog out interface on the VPFlowScope M Transmitter becomes an alarm output. The analog out interface is a 'non potential' free output as it acts like an active current loop. To make it passive, an external third party isolator can be used.

The alarm boundaries can be set using Modbus or VPStudio software. By setting 'analog min', the lower boundary of the safe (non-alarm) zone is set. By setting 'analog max', the upper boundary of the safe (non-alarm) zone is set. When the selected measurand exceeds the set safe-zone, the alarm is activated.

To select a measurand for operating the alarm on, a unit has to be set. For example, setting a pressure unit selects the device pressure measurand by extension thereof. The selected measurand will be compared to the configured boundaries, all expressed in the selected unit. To set analog min, analog max, analog unit and analog mode using a Modbus master, [see chapter 8](#) for Modbus registers.

When the alarm is activated, the analog out interface will be at the same voltage as the wire used to power the device, whilst providing at most 20mA. In addition to signaling the alarm on the analog out interface, the alarm LED on the device is lit for the duration of the alarm situation.

Disabling the lower or upper boundary

To disable the lower or upper boundary, a sufficiently high or low value has to be configured, ensuring the set boundary will never be exceeded.

Signal periods

The selected measurand is evaluated according to the set boundaries every second. An alarm signal (logical high) therefore is at least one second in duration, and will return to logical low when the measurand is in the safe-zone again.

The Alarm mode of the VPFlowScope M does not have a configurable hold and/or reset period. If such functionality is required, a third party timed relay can be used.

Counter

An alarm counter is available that counts the number of triggered alarms. Every alarm event will increase the alarm counter. The alarm counter is persistent over power cycles. The alarm counter can be read and reset using Modbus.

7.3 RS-485

RS-485 is a serial interface which can be used to connect the VPFlowScope M Transmitter to VPVision, remote monitoring software, data acquisition mechanisms or a building management system. RS-485 is standardized as described in ANSI/TIA/EIA-485-A-98.

For devices to communicate using this serial interface, settings must be identical on both ends of the connection. Various settings are available to match any device or controller the VPFlowScope M Transmitter is to communicate with.

Communication settings

The RS-485 communication settings can be changed by means of the device display and buttons, Modbus or VPStudio.

- Baud rate: 9600 | 19200 | 38400 | 57600 | 115200
- Parity: None | Even | Odd | Mark | Space
- Stop bits: 1 | 2 | 1.5

Factory default is: 38400, none, 1 (38400N1)

The VPFlowScope M Transmitter uses RS-485 to transport **Modbus RTU** messages. For more information on what data can be read or written using Modbus, see [chapter 8](#).

7.4 Ethernet

Ethernet is a network bus which can be used to connect the VPFlowScope M Transmitter to VPVision, remote monitoring software, data acquisition mechanisms or a building management system. The VPFlowScope M Transmitter supports double twisted-pair variants of Ethernet, commonly referred to as 10BASE-T and 100BASE-TX, standardized as IEEE 802.3i-1990 and 802.3u-1995.

The VPFlowScope M Transmitter uses Ethernet to transport **Modbus TCP** messages. For more information on what data can be read or written using Modbus, see [chapter 8](#).

The VPFlowScope M Transmitter can be connected to a computer or network equipment using a cable with one M12 4-pin connector and one RJ45 connector. [See chapter 9.5](#) for more information.

For Modbus TCP to function, a usable IP address must be configured. Address configuration is dependent on configuration expected by the network equipment and infrastructure. Configuring network settings can be done using the device display and buttons, Modbus or VPStudio.

The default Ethernet setting is DHCP.

The default static settings are listed in the following table:

Default settings	
IP address	192.168.1.123
Net mask	255.255.255.0
Gateway	192.168.1.1
Modbus port*	502

*Value is fixed and cannot be changed

7.5 USB

The VPFlowScope M Transmitter also features a USB port, which can be used to connect the Transmitter to a personal computer. The USB port is to be found on the bottom-side of the Transmitter, hidden and protected by a screw-cap. Specifications if needed are available on request from the USB Implementers Forum.

When connected, USB-serial emulation is initiated, showing the device as a standard comport on MS Windows or ttyUSB on Linux. On Windows, use the Device Manager, on Linux, list /dev to see which enumeration has been assigned to the VPFlowScope M Transmitter.

The VPFlowScope M Transmitter uses USB to transport **Modbus RTU** messages. For more information on what data can be read or written using Modbus, see [chapter 9](#).

Any USB Mini-B cable will suffice to connect the VPFlowScope M Transmitter. When connected, the presented USB-serial emulation comport can be used in identical fashion as a VPInstruments JB-5 kit, which includes a USB-serial / RS-485 dongle. Power supplied by the personal computer over the USB cable is insufficient to fully operate the VPFlowScope M: All functionality but measurement is available.

USB host ports typically supply at most 500mA at 5V, which is insufficient to power the thermal measurement process in the VPSensorCartridge. For the VPFlowScope M to be fully operational, 14-24VDC must be applied. All other functionality however is available when solely powered over USB.

After having used the USB port, be sure to check the O-ring on the USB cover screw-cap. This screw-cap must be screwed back in place after having used the USB port, in order to retain the device IP-rating. Hand-tightening the cap is sufficient.

7.6 Display

The VPFlowScope M Transmitter is available as various models. The models including a display can be used as a real-time viewer for current measurements and, in combination with the build-in keypad, for configuration purposes.

7.6.1 Keypad

The key pad contains 4 buttons to control the Transmitter.

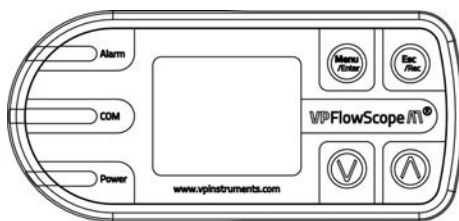

Menu / Enter

Used to enter the (sub)menu or to confirm a setting

Escape / Record

Will return from a (sub)menu to a higher level in the menu structure, returning to the main screen
 "Record" no longer bears any meaning since firmware 2.0: The concept of sessions has been abandoned in favor of always recording to a year-long circular buffer

Up button

Change main page / Navigate up in the menu

Down button

Change main page / Navigate down in the menu

7.6.2 Main pages

The main page is what the user is greeted with once the device has been powered-up. The main page shows one or more measurands and their most recent (real time) values.

More precisely, there are three main pages: One showing 3 measurands, one showing 2 measurands, one showing a single measurand. Using the up and down buttons, the user can switch main pages.

These main pages can each individually be configured to show certain measurands. By pressing the menu button, a menu structure is presented. In the settings menu, an option for changing page units can be found, using which the user can select various units and by extension thereof a corresponding device measurand. Each page has an independent configuration, which can be customized to suit the user's needs.

The main page displaying a single measurand uses a larger font than is used on the main page displaying 3 measurands. Having multiple main pages available serves a dual-purpose: Multiple main pages enables configuring a larger preset collection of measurands, while simultaneously providing multiple font sizes for real time measurement values.

7.6.3 Menu

The VPFlowScope M Transmitter menu is categorized into Settings, Info/about items and Device operations.

1 Settings

All items related to device configuration are grouped in the Settings sub-menu. Ideally these have to be set once, whereafter the device functions as desired.

1.1 Diameter

For correct operation, the exact inner pipe diameter has to be set: Inner pipe diameter is used to calculate the surface area of the pipe cross-section, using the formula $(d/2)^2$. Setting a wrong inner diameter will lead to very significant misreadings, due to velocity not being properly converted to volumetric units. In addition to improper conversions from velocity to volume, setting a wrong inner diameter also affects velocity calculations, as the VPSensorCartridge compensates for flow profiles dependent on the inner pipe surface area.

1.2 Display

The VPFlowScope M Transmitter firmware 2.0 and newer features a screen rotation option, in case the installation environment requires odd positioning of the Transmitter. In case lighting in the environment requires so, the display can also be set to a dark-theme, which toggles colors inverted and increases contrast of items on screen.

1.3 Page Units

Measurands shown on Main pages and which units they are expressed in is fully configurable.

1.4 Date and time

The VPFlowScope M keeps track of time internally for a variety of purposes, the most prominent being datalogger functionality: The datalogger used in the VPFlowScope M Transmitter firmware 2.0 and newer is designed as a one-year circular-buffer, where the device date and time dictates where in this buffer data is being written. To make proper use of the datalogger functionality, a correctly set date and time is therefore paramount.

To set the device date and time, select the menu option and set the date using the key pad. The date is formatted as: DD-MM-YYYY. After setting the date, confirm using the enter button and input the current time. Time is formatted as: HH:MM:SS. Again, confirm with the enter button. The data logger expects date and time of the device to be set to UTC. The newly input date and time will become active immediately.

In addition to using the on display menu, device date and time can also be read and written using Modbus. This is done by reading and writing a 32 bit register, which holds a Unix epoch timestamp.

For more information on how date and time can be read or written using Modbus, see [chapter 8](#). Alternatively, VPStudio can be used to execute this read and write.

The VPFlowScope M features an internal real time clock. This clock is powered by a backup battery in the event VPFlowScope M loses external power. This battery can power the clock at least 5 days at room temperature. If all of the battery charge is spend, device date and time will reset to a programmed in default, which will be near the release date of the used firmware version. When the VPFlowScope M is on external power, the internal battery will be fully charged in about 2 minutes.

1.5 Connectivity

The VPFlowScope M includes various means to communicate with other electronic devices and/or systems. To integrate the VPFlowScope M by connecting it to other components, these means to communication, more commonly called interfaces, may need changes to their default configuration.

All interfaces function concurrently, meaning they are all active and usable at the same time.

1.5.1 Modbus

Modbus is the protocol used by the VPFlowScope M for all machine to machine communication. When using Modbus, individual devices are addressed by their configured slave address. The slave address your VPFlowScope M responds to is configurable by the display and buttons. The slave address can be set to any number in the 1 – 247 range.

This configured address is used by all Modbus RTU communication, being over RS-485 and USB serial. Modbus TCP does not utilize this slave address field, as devices are already addressed by their IP address used over Ethernet.

1.5.2 RS-485

RS-485 is a serial bus commonly used in field applications. Modbus messages are very commonly transported using RS-485, and for this reason the RS-485 interface is often confused with Modbus itself. The VPFlowScope M also uses RS-485 to transport Modbus messages, and hence for Modbus RTU to work, the RS-485 settings need to match those of the other equipment to be communicated with.

RS-485 settings are irrelevant for Modbus TCP, which is transported using Ethernet.

For the RS-485 bus to function, a total of three parameters must match on both ends of communication:

Baudrate	Symbol (data) rate
Parity	Method of error-checking
Stopbits	Silence-period denoting the end of a symbol transmission

1.5.3 Analog

The VPFlowScope M Transmitter also supports analog output, to enable usage of measurements by the VPFlowScope M as input to analog systems. One analog output is available per Transmitter, which can be configured to output different signals.

1.5.3.1 Mode

The analog output can produce three different signals, meaning it can be used in three different modes. The desired mode depends on what analog system design takes the VPFlowScope M signal as input.

4..20mA	Closed current-loop signaling, encoding any qualitative measurement
Pulse	One-second length pulses, encoding volume having passed the sensor
Alarm	High or low, encoding a qualitative measurement being out of bounds

1.5.3.2 View

The measurand being signaled using the analog output, and the boundaries can be adjusted here. Selecting a flow unit, for example liter per second, will select the VPFlowScope M flow measurand by extension thereof.

Lower boundary

Interpretation of the lower boundary value depends on set mode:

4..20mA	Value to be represented by 4mA
Pulse	Volume to be represented by one pulse
Alarm	If the measurand falls below this value, alarm is raised

Upper boundary

Interpretation of the upper boundary depends on set mode:

4..20mA	Value to be represented by 20mA
Pulse	No function
Alarm	If the measurand rises over this value, alarm is raised

1.5.4 Ethernet

The VPFlowScope M Transmitter uses Ethernet to transport Modbus TCP messages. For Modbus TCP messages to be received and send, a valid IP address needs be configured.

Configuration of an IP address can be done in two ways: By asking a network service called DHCP for a set of valid numbers, or by manually entering valid numbers.

1.5.4.1 Overview

The overview shows the current set of configured IP addresses. If the user manually configured the IP addressing settings, they are shown in the overview. If the user has set DHCP as method for configuring IP addressing settings, numbers shown are as received from the DHCP server.

In case the network requires devices to be white-listed, atop the overview, the MAC-address or hardware address is shown. Depending on the network configuration, this hardware address needs be provided to the network administrator in order for the DHCP server to lease an IP address to the VPFlowScope M Transmitter.

1.5.4.2 Static IP settings

If the VPFlowScope M is to be used in a network environment without DHCP service, or when using the DHCP service is not desired, IP addressing configuration has to be manually entered. Ask your network administrator for the correct values.

1.6 Advanced

The advanced menu provides extra options concerning the cartridge and flow output.

1.6.1 Ref. cond.

The reference condition for flow can be selected. The reference condition is applied to velocity, flow and totalizer units

1.6.2 Direction Cal.

The Direction calibration feature allows users to fine-tune the direction signal, ensuring accurate output in low range applications. This feature is exclusively available for bi-directional cartridges.

1.6.3 Direction

VPFlowScope M has the option to disable Direction Sensitivity, allowing the user to use a bi-directional cartridge as a uni-directional one. This feature is exclusively available for bi-directional cartridges.

2 Info / about

The info menu structure offers various details about the Transmitter and connected cartridge such as firmware version, serial number, sensor ranges and model name.

3 Device

Unlike settings, which ideally have to be set once, device operations such as restarting, resetting counters or factory reset of the device may be desired on multiple occasions.

3.1 Reset totalizer

The VPFlowScope M Transmitter keeps an internal volume administration, known as the totalizer. In case the user want the totalizer to be reset to zero, this options allows you to do so.

The totalizer can only be reset to zero. It cannot be set to arbitrary values.

3.2 Restart

This option restart the Transmitter. All peripherals of the Transmitter will be reinitialized. Effect is near-identical to resetting the device by removing and reapplying power. Removing power however also affects the cartridge, which needs to warmup again when power is restored. The restart menu option does not affect the cartridge.

3.3 Factory reset

The Transmitter will be put back in factory default settings, removing all user configuration and data.

7.7 Data logger

The optional data logger enables you to record data. The datalogger used in the VPFlowScope M Transmitter firmware 2.0 and newer is designed as a one-year circular-buffer. Whenever the device is powered and has a VPSensorCartridge connected, data is being recorded.

Using VPStudio, recorded data can be downloaded from the device, either over Modbus RTU (RS-485, USB serial) or Modbus TCP (Ethernet). Device operation is not interrupted when data is being downloaded.

Data is being stored with one second interval, recording flow, pressure, temperature and totalizer.

When data is being written to the one-year circular-buffer, device date and time dictates where in this buffer data is being written. To make proper use of the datalogger functionality, a correctly set date and time is paramount!

8 Modbus

Modbus is a protocol commonly used in data acquisition and industrial control environments. The protocol defines a control topology and various message structures, while having little to no dependencies on specific types of wiring. In practice however almost all Modbus communication is carried by RS-485 and Ethernet.

The VPFlowScope M Transmitter supports the Modbus RTU and TCP variants: Modbus RTU is available over its RS-485 and USB-serial interfaces, whereas Modbus TCP can be used using its Ethernet interface.

For a complete introduction to the Modbus standard, visit <https://modbus.org/>, more specifically https://www.modbus.org/docs/Modbus_over_serial_line_V1_02.pdf. Alternatively <https://en.wikipedia.org/wiki/Modbus> also provides some good reading.

VP Instruments strongly recommends familiarizing oneself with Modbus before attempting any installation or modification efforts on any system. The VPFlowScope M manual assumes you are familiar with the Modbus communication standard, its wiring and best practices.

All measurement parameters are available over Modbus in floating point and integer format. All measurement data is refreshed at 1 Hz.

The factory default settings are hardware address 9 and integer multiplier 10.

Supported Modbus commands

Function code 0x03 for reading (Holding register)

Function code 0x06 for writing single register (Holding register)
 Function code 0x10 for writing multiple registers (Holding register)

Endianess of integer

Byte order within each register is mandated by the Modbus standard to be big-endian. The byte order within words therefore is big-endian. Endianess of the word order however is not specified or mandated in any way by the Modbus standard. Different vendors have different ideas about this, the most common denominator seems to be little-endian word order. VP Instruments has decided to go along with the most common denominator.

- Byte order within words (registers) is big-endian (as mandated by the Modbus standard)
- Word order when reading multiple registers is little-endian (current most common format among all Modbus vendors)

Endianess of floating-point

The VPFlowScope M presents floating-point values encoded according to IEEE 754, otherwise known as IEEE Standard for Floating-Point Arithmetic. IEEE 754 mandates a big-endian byte order, 4 bytes total. When reading floating-point values from the VPFlowScope M, this is achieved by reading two consecutive registers (a word or 2 bytes each). The read result should be interpreted as an array in big-endian order.

8.1 Register table

This table is written counting from 0. Register 0 is the first index. The first register is unused. The second register, index 1, is the first register used by this device.

HEX	Decimal	Description	Type	Read / Write
<u>General information</u>				
0001 - 0002	1 - 2	Transmitter serial number	32-bit integer	Read
0003 - 0005	3 - 5	Transmitter firmware version	3 bytes	Read
0006 - 0007	6 - 7	Transmitter production date	32-bit integer	Read
0032 - 0033	50 - 51	Cartridge serial number	32-bit integer	Read
0034 - 0036	52 - 54	Cartridge firmware version	3 bytes	Read
0037 - 0038	55 - 56	Cartridge calibration date	32-bit integer	Read
0039 - 003A	57 - 58	Cartridge production date	32-bit integer	Read
<u>Flow</u>				
0064 - 0065	100 - 101	Flow range min m_n /sec	Floating point	Read
0066 - 0067	102 - 103	Flow range max m_n /sec	Floating point	Read
0068 - 0069	104 - 105	Flow m_n /sec	Floating point	Read
006A - 006B	106 - 107	Flow sfps	Floating point	Read
006C - 006D	108 - 109	Flow m^3_n /hr	Floating point	Read
006E - 006F	110 - 111	Flow m^3_n /min	Floating point	Read
0070 - 0071	112 - 113	Flow m^3_n /sec	Floating point	Read

0072 - 0073	114 - 115	Flow l_n /min	Floating point	Read
0074 - 0075	116 - 117	Flow l_n /sec	Floating point	Read
0076 - 0077	118 - 119	Flow SCFM	Floating point	Read
0082 - 0083	130 - 131	Flow m_n /sec	32-bit integer	Read
0084 - 0085	132 - 133	Flow sfps	32-bit integer	Read
0086 - 0087	134 - 135	Flow m_n^3 /hr	32-bit integer	Read
0088 - 0089	136 - 137	Flow m_n^3 /min	32-bit integer	Read
008A - 008B	138 - 139	Flow m_n^3 /sec	32-bit integer	Read
008C - 008D	140 - 141	Flow l_n /min	32-bit integer	Read
008E - 008F	142 - 143	Flow l_n /sec	32-bit integer	Read
0090 - 0091	144 - 145	Flow SCFM	32-bit integer	Read
<u>Pressure</u>				
0096 - 0097	150 - 151	Pres range min	Floating point	Read
0098 - 0099	152 - 153	Pres range max	Floating point	Read
009A - 009B	154 - 155	Pres Bar gauge	Floating point	Read
009C - 009D	156 - 157	Pres Psi gauge	Floating point	Read
00B4 - 00B5	180 - 181	Pres Bar gauge	32-bit integer	Read
00B6 - 00B7	182 - 183	Pres Psi gauge	32-bit integer	Read
<u>Temperature</u>				
00C8 - 00C9	200 - 201	Temp range min	Floating point	Read
00CA - 00CB	202 - 203	Temp range max	Floating point	Read
00CC - 00CD	204 - 205	Temp celsius	Floating point	Read
00CE - 00CF	206 - 207	Temp fahrenheit	Floating point	Read
00D0 - 00D1	208 - 209	Temp Kelvin	Floating point	Read
00E6 - 00E7	230 - 231	Temp celsius	32-bit integer	Read
00E8 - 00E9	232 - 233	Temp fahrenheit	32-bit integer	Read
00EA - 00EB	234 - 235	Temp Kelvin	32-bit integer	Read
<u>Totalizer</u>				
00FA - 00FB	250 - 251	Totalizer m_n^3	Floating point	Read
00FC - 00FD	252 - 253	Totalizer positive m_n^3	Floating point	Read
00FE - 00FF	254 - 255	Totalizer negative m_n^3	Floating point	Read
0100 - 0101	256 - 257	Totalizer MSCF	Floating point	Read
0102 - 0103	258 - 259	Totalizer positive MSCF	Floating point	Read
0104 - 0105	260 - 261	Totalizer negative MSCF	Floating point	Read
0113 - 0114	275 - 276	Totalizer m_n^3	32-bit integer	Read

0115 - 0116	277 - 278	Totalizer positive m_n^3	32-bit integer	Read
0117 - 0118	279 - 280	Totalizer negative m_n^3	32-bit integer	Read
0119 - 011A	281 - 282	Totalizer MSCF	32-bit integer	Read
011B - 011C	283 - 284	Totalizer positive MSCF	32-bit integer	Read
011D - 011E	285 - 286	Totalizer negative MSCF	32-bit integer	Read
<u>Alarm</u>				
0130 - 0131	304 - 305	Alarm counter	32-bit integer	Read
0132 - 0132	306 - 306	Alarm status	16-bit integer, true/false	Read
<u>Alarm/Analog out</u>				
0136 - 0137	310 - 311	Analog low boundary	Floating point	Read / write
0138 - 0139	312 - 313	Analog high boundary	Floating point	Read / write
<u>Configuration registers</u>				
03E8 - 03E8	1000 - 1000	Totalizer reset all	16-bit	Write, any value
03E9 - 03E9	1001 - 1001	Alarm counter reset	16-bit	Write, any value
03F3 - 03F4	1011 - 1012	System time Unix timestamp	32-bit integer	Read / write
0406-0406	1030-1030	Reference conditions	16-bit enum	Read / write
0407-0407	1031-1031	Bi-directional	16-bit enum	Read / write
0408-0408	1032-1032	Direction calibration	write: 16-bit read: 16-bit enum	Write, 1974 to start Read, status
0422 - 0422	1058 - 1058	Analog output unit	16-bit enum	Read / write
0423 - 0423	1059 - 1059	Analog output mode	16-bit enum	Read / write
044C - 044D	1100 - 1101	Diameter mm*	Floating point	Read / write
04B0 - 04B0	1200 - 1200	Modbus address	16-bit integer	Read / write
04B1 - 04B1	1201 - 1201	Modbus multiplier	16-bit integer	Read / write
0514 - 0514	1300 - 1300	RS-485 baudrate	16-bit enum	Read / write
0515 - 0515	1301 - 1301	RS-485 parity	16-bit enum	Read / write
0516 - 0516	1302 - 1302	RS-485 stopbits	16-bit enum	Read / write
0640 - 0640	1600 - 1600	Device restart	16-bit	Write, any value
0641 - 0641	1601 - 1601	Device factory reset	16-bit	Write, 0x400B

*Refer to the section [Configuration](#) for the minimum and maximum programmable diameters.

8.2 Enumerations

<u>Analog output unit enum</u>		
Enum	Description	Type
0	Normalized meter per second	Velocity
1	Standard feet per second	Velocity
2	Normalized cubic meter per hour	Flow
3	Normalized cubic meter per minute	Flow
4	Normalized cubic meter per second	Flow
5	Normalized liter per minute	Flow
6	Normalized liter per second	Flow
7	Standard cubic feet per minute	Flow
8	Bar gauge (relative to atmosphere)	Pressure
9	Pounds per square inch gauge (relative to atmosphere)	Pressure
10	Degrees Celsius	Temperature
11	Degrees Fahrenheit	Temperature
12	Kelvin	Temperature
13	Normalized cubic meter	Volume
14	Standard cubic feet	Volume
15	1000's of standard cubic feet	Volume
16	1000,000's of standard cubic feet	Volume
17	Normalized liter	Volume
20	Millibar gauge (relative to atmosphere)	Pressure
21	Pascal gauge (relative to atmosphere)	Pressure
23	Millipascal gauge (relative to atmosphere)	Pressure

<u>Analog output mode enum</u>	
0	4..20mA
1	Pulse
2	Alarm

<u>RS-485 baudrate enum</u>	
0	9600
1	19200
2	38400
3	57600
4	115200

<u>RS-485 parity enum</u>	
0	None
1	Even
2	Odd
3	Mark
4	Space

<u>RS-485 stopbits enum</u>	
0	1 stopbit
1	2 stopbits
2	1.5 stopbits

<u>Reference conditions</u>	
0	Normalized DIN 1343 (Default)
1	FAD (ISO 1217)
2	ISO 2533 (Sea Level)

<u>Bi-directional</u>	
0	Off
1	On (default when bi-directional is purchased)

<u>Direction calibration status</u>	
0	DIRECTION_CALIBRATION_IDLE
1	DIRECTION_CALIBRATION_RUNNING
2	DIRECTION_CALIBRATION_FINISHED
3	DIRECTION_CALIBRATION_FAILED

9 Electrical connections



NEVER USE AC POWER. THIS WILL VOID WARRANTY AND BRING PERMANENT DAMAGE TO THE ELECTRONICS. THE INSTRUMENT MIGHT BE DAMAGED BEYOND REPAIR.
CONNECT THE M12 CONNECTOR BEFORE POWERING UP THE INSTRUMENTS.

The Transmitter is equipped with a M12 5-pin connector which contains the power input, an analog output and a Modbus interface.

Pin	Signal	Wire color
1	+14...24 VDC	Brown
2	0 Volt	White
3	4..20 mA signal, active	Blue
4	RS-485 B/+	Black
5	RS-485 A/-	Grey

* Wire colors apply to VPI instruments cables

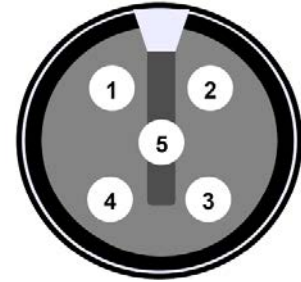

M12 5-pin female connector

Cabling

Shielded twisted pair cabling must be used for proper communication and measurement. Connect shield to safety ground on one point. The thickness of the wires depends on the cable length. For cabling below 300 meter | 1000 ft, use 20 awg. For longer runs use 18 awg or better.

Power supply

The input voltage is 14 to 24VDC. Make sure that the power supply is at least 14V at the connector. Voltage drops will occur in long cables resulting in insufficient power. The display will notify you when there is insufficient power.

9.1 4..20mA

An advantage of a current loop is that the accuracy of the signal is not affected by voltage drop over the line. Even if there is significant electrical resistance in the line, the current loop Transmitter will maintain the proper current, up to its maximum voltage capability. The live-zero represented by 4mA allows the receiving instrument to detect some failures of the loop. An analog current loop can be converted to a voltage input with an external third party precision resistor.

The Transmitter output is an active, non- isolated linearised current loop. This means that the + wire is shared between power supply and the analog output. A current will draw back from the instrument to the power supply.

Cabling

3 wires are required to create a current loop. It is advised to use a shielded cable to prevent electrical noise to affect the signal.

Ohm's law can be used to calculate the maximum distance. There are 2 parameters that needs to be taken into account.

1. The voltage available is equal to the input voltage
2. The resistance depends on cable quality and length

Example:

Input voltage 24V
 Required maximum current 20mA

$$24V / 0.02A = 1200 \text{ Ohm}$$

1200 Ohm is the maximum load that can be applied with a 24V input level.

Above example does not include the current consumption of the flow meter itself. When power to the flow meter is applied using a long cable, include a current consumption of 500mA to the formula.

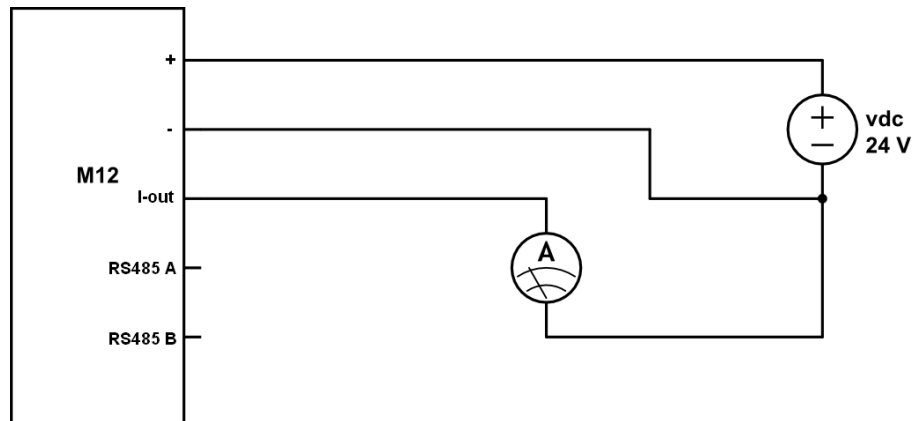
Electrical scheme

The current meter is placed in between the current output and the power supply ground. You can also use a digital multimeter to test the current output.

9.2 Pulse

The pulse output is an active non potential free current output. This means that the + wire is shared between power supply and the pulse output. The output signal will be 0mA in idle state. When a pulse is generated, a 20mA signal will be outputted for 1 second.

The counter can be placed between the pulse output and the power supply - (neg).

Cabling

The electrical specifications are identical to the 4..20mA output. Therefore the suggested cabling is identical.

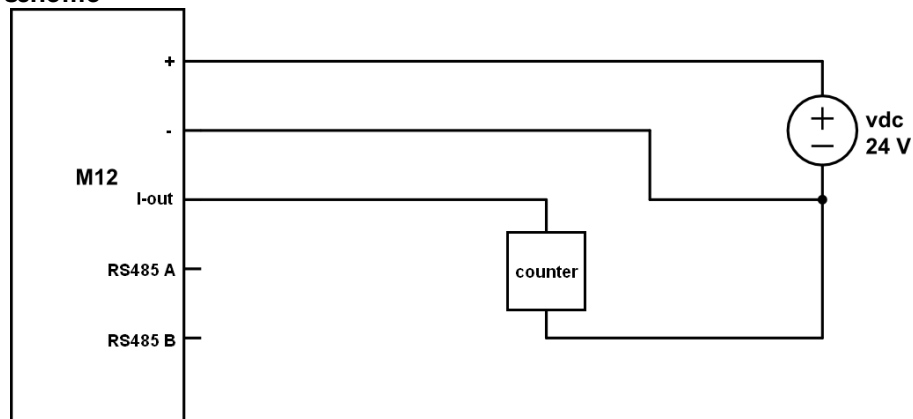
Electrical scheme

9.3 Alarm

The alarm output is an active non potential free current output. This means that the + wire is shared between power supply and the alarm output. The idle current will be 0mA. When an alarm is triggered, the alarm output will go to 20mA. The alarm output can be wired into a central data acquisition / building management system as signal. An external control current relay is required to switch on lamps or buzzers. When selecting a relay, make sure that the input can be controlled by a current signal.

Cabling

The electrical specifications are identical to the 4..20mA output. Therefore the suggested cabling is identical.

Electrical scheme

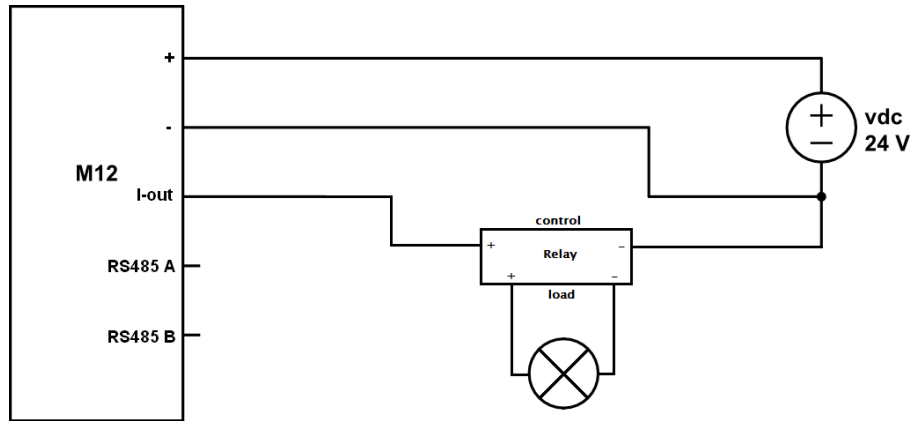

9.4 RS-485



Installing a RS-485 network require specific knowledge. Not following the specifications strictly might result in in-correct communications and equipment damage. Please leave installation up to professional contractors. Make sure that they read this chapter carefully and follow up all RS-485 guidelines.

RS-485 is a differential balanced line over twisted pair. It can span relatively large distances up to 1200 meter | 4000 feet. The wires should be connected as a point-to-point configuration, or also called daisy chain. Do not install as star or ring network! The trunk line goes from the master to all devices making a drop down to each device. The cable length from the trunk line to the Modbus device needs to be as small as possible. Junction boxes are used to make the T junction.

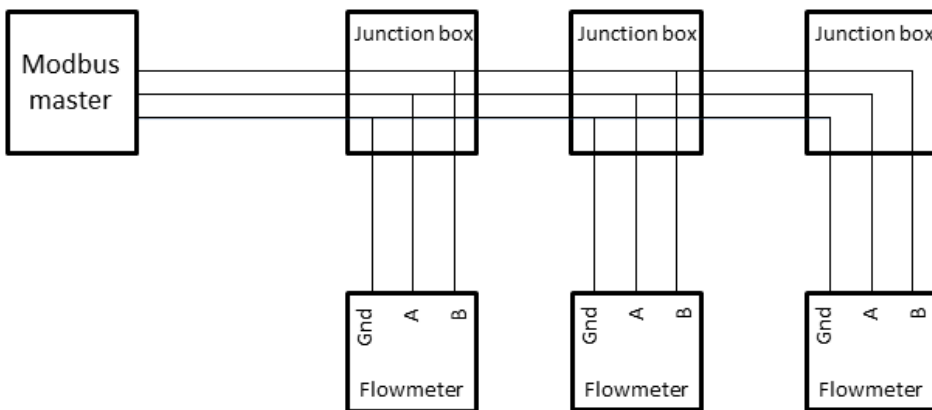

Shielded twisted pair should be used. Connection of a third wire between the master and slave should be done to limit the common mode voltage that can be impressed on the slaves inputs. The required cable quality depends on the total cable distance, the number of nodes and the environmental influences. A local contractor can help you select the right cable for your application.

Termination resistor

Termination resistors reduce electrical noise sensitivity. They need to be added to the installation when cable distances become longer than 10 meter. The value of each termination resistor should be equal to the cable characteristic impedance (typically, 120 ohms for twisted pairs).

There can only be one termination resistor at the very end of the trunk line. The VPInstruments junction box features a jumper that can be used to enable a 120 Ohm resistor. When using the VPInstruments Modbus Junction boxes make sure that the 120 Ohm resistor is only enabled in the last Modbus Junction box in the daisy chain.

Biasing

When there is no data activity on an RS-485 network, the communications lines are "floating" and, thus susceptible to external noise or interference. Receivers on a RS-485 network have built in hysteresis (200mV differential required to insure known state). To insure that a receiver stays in an inactive state, when no data signal is present, bias resistors are required. Bias resistors are a pull-up resistor on Modbus B and a pull-down resistor on the Modbus A line. The value of the bias resistor depends on the number of devices and the supply voltage. The table below shows which resistor values can be used for different voltage in a chain with 1 to 8 VPFlowScope M's.

Supply voltage	Bias pull up	Bias pull down
14 V	5 K	1 K
24 V	10 K	1 K

Bus power

The VPFlowScope M can be powered via the same trunk line. 2 separate wires are used for power + and power -. Take in account that long wires with multiple slaves will cause voltage drops. The minimum supply voltage is 14VDC measured at the last VPFlowScope M in the daisy chain.

Electrical scheme

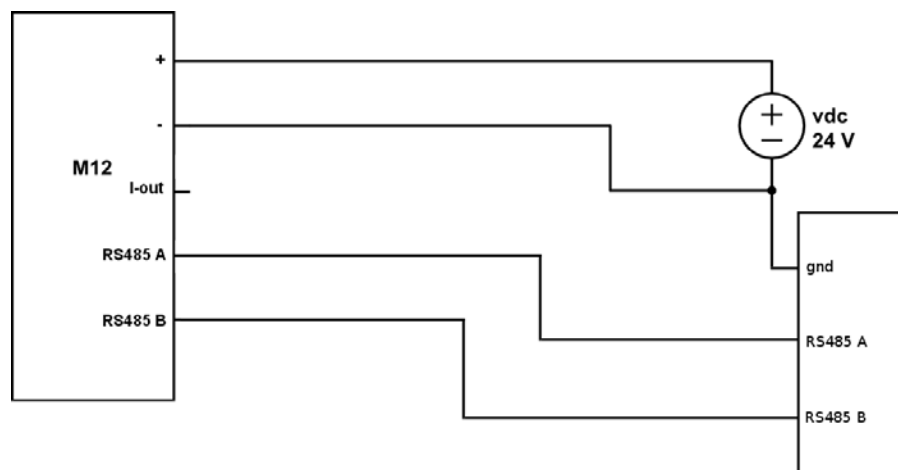

9.5 Ethernet

Ethernet is available through a M12 4-pin d-coded connector. It uses the industry standard pin-out for Ethernet. The table below shows how to wire from M12 to the RJ45 Ethernet plug. When creating your own cable, make sure that shielded twisted pair (STP) wire is used. The maximum length for all Ethernet cables is 150 meter.

M12 Pin	Ethernet pin	Wire color
1	1	White / Orange
2	3	White / Green
3	2	Orange
4	6	Green

T568B standard



M12 4-pin female connector

We offer 2 types of cables for connecting your Transmitter to the Ethernet.

Order code	Connectors	Description
VPA.5004.0005	M12 to RJ45	Connection to routers or switches 5 meter 16.4ft
VPA.5004.0105	M12 to M12	Extension cord 5 meter 16.4ft

10 VPStudio software

The VPFlowScope M can be read out and configured with the VPStudio 4 software. This software can be downloaded from <https://www.vpinstruments.com>. VPStudio 4 is only available for Windows and has been tested on Windows 10 and newer versions.

A quick start is shown below.

Connecting the Transmitter

Modbus communication from your PC to the VPFlowScope M is established using a USB cable. By unscrewing the protective cap on the bottom of the VPFlowScope M body, a USB-mini socket can be found. When properly connected to your PC, serial emulation is initiated, creating a virtual COM-port. VPStudio 4 will then send Modbus RTU messages over this virtual COM-port.

It is also possible to use a JB5 kit for connecting the VPFlowScope M to VPStudio 4.

Firmware update

A separate firmware updater is available in the VPStudio 4 software.

11 Exchanging VPSensorCartridges

With the patented VPSensorCartridge concept, traditional re-calibration is something no longer required. From now on, you simply exchange the VPSensorCartridge, and continue your measurements with nearly zero downtime. All settings are stored in the Transmitter and are automatically transferred to the newly installed VPSensorCartridge.

Your benefits:

- Near zero downtime
- Less logistics/customs cost and involvement

Exchanging instructions can be found in section [Replacing the VPSensorCartridge](#).

12 Specifications Transmitters



Please always check the label of your product for the specifications.
Specifications are subject to change as we are continuously improving our products.
Please contact us to obtain the latest specification sheet.

Sensor interface

VPSensorCartridge Proprietary interface, rotational 360 degrees

Display

Display type 1.8" TFT with auto power save (option)
LED status LED indicators on all models for power, communication and alarm

Data logger

Memory One-year circular memory, 1 x per second logging interval for all parameters
Logging mode Cyclic

Outputs

RS-485 Modbus RTU
Analog output Configurable: 4..20mA, pulse, alarm
USB Serial emulation, Modbus RTU
Ethernet IP addressing, Modbus TCP

Mechanical & Environmental

Dimensions 50 x 108 x 36 mm | 1.97 x 4.25 x 1.42 inch
Weight 220 grams | 7.76 ounces including locking ring
Material Aluminium, anodized body with polycarbonate cover
O-ring seals NBR
Protection grade IP65 | NEMA 4 when mated to VPSensorCartridge and USB cap tightened
Ambient temperature 0...60°C | 32...140°F
Ambient humidity 10 - 95%. Avoid condensation at all times

Avoid direct rain and sunlight or radiant heat. Extreme temperature fluctuations may affect the IP grade over time

Highly corrosive or acid environments should be avoided

Electrical

Supply 14VDC(*)..24 VDC +10% CLASS 2 (UL)
Power consumption 1 Watt (no flow) 3.5 Watt (full flow) +/- 10%

Certification

CE EN 60950-1, EN 61326-1, EN 61000-3-2, EN 61000-3-3, EN 61326-1
UL UL 508

** 14 Volt should be available at the input terminal under all flow conditions and all environmental conditions. Cable resistance and power supply impedance, which are temperature dependent, will cause permanent and transient voltage drops. These voltage drops have to be taken into account when designing and implementing the electrical installation. The VPFlowScope M continuously monitors available input voltage and will automatically turn into power save mode when the supply voltage drops below 11.8 Volt. For maximum power reliability under all circumstances, we recommend to use 24 VDC.*

13 Specifications VPSensorCartridges



Please always check the label of your product for the specifications.

Specifications are subject to change as we are continuously improving our products. Please contact us to obtain the latest specification sheet.

Flow sensor

Measuring principle	Thermabridge™ Thermal Mass
Flow range	0...150 m _n /sec 0...500 sfps Minimum detection level: 0.5 m _n /sec 1.7 sfps
Bi-directional flow	Optional
Accuracy	P35X models: Diameter > 50 mm 2": 2% of reading under calibration conditions Diameter < 50 mm 2": 10% of reading under calibration conditions P22X models: Diameter > 50 mm 2": 2% of reading under calibration conditions Diameter < 50 mm 2": 3% of reading under calibration conditions
Reference conditions	<ul style="list-style-type: none"> • 0 °C, 1013.25 mbar 32 °F, 14.65 psi DIN1343 (Default) • 20 °C, 1000 mbar 68 °F, 14.5 psi ISO1217 (FAD) • 15 °C, 1013.25 mbar 59 °F, 14.65 psi ISO 2533 (Sea level)
Gases	Compressed air, Nitrogen and inert, non condensing gases
Gas temperature range	0...60 °C 0...140 °F

Pressure sensor

Pressure range	P35X models: 0...10 bar 0...145 psi gauge P22X models: 0...16 bar 0...250 psi gauge
Accuracy	+/- 0.05 bar (at 25°C) +/- 0.76 psi (at 77°F)
Total error band	+/- 0.315 bar +/- 4.50 psi

Temperature sensor

Temperature range	0...60 °C 32...140 °F
Accuracy	> 10 m/sec: +/- 1 °C 1.8 °F < 10 m/sec: + 5 °C 9 °F

Mechanical & Environmental

Probe Length	P35X models: 340 mm 13.4" P22X models: 220 mm 8.67"
Weight	P35X models: 200 grams 7.05 ounces P22X models: 246 grams 8,67 ounces including compression fitting with integrated safety lock
Process connection	Compression fitting, 1/2" NPT, Tapered
Pressure rating	P35X models: PN10 P22X models: PN16
Protection grade	IP65 NEMA 4 when mated to Transmitter
Ambient temperature range	0...60 °C 32...140 °F, avoid direct sunlight or radiant heat
Wetted materials	Probe: Anodized aluminum (tip) and SS316L (stem) Sensor: Silicon, epoxy, glass Sealing: FPM 60
Corrosion resistance	Highly corrosive or acid environments should be avoided

Electrical

Connection type	VPSensorCartridges proprietary
-----------------	--------------------------------

Power consumption

See Transmitter specifications for combined power consumption

14 Order information and accessories

14.1 Transmitter

Order Code	Option	Feature
VPM.T0001	D000	Basic
	D010	Basic + display
	D011	Basic + display + data logger

Available models on day of printing

Basic features	Display features	Data logger
RS-485 (Modbus RTU) Configurable analog: 4..20mA, pulse, alarm Ethernet (Modbus TCP) Alarms LEDS	Graphical display Keypad for configuration	Cyclic One-year circular memory

14.2 VPSensorCartridge

Order Code	Flow	Temperature	Pressure	Bi-directional
VPM.R150.P350.PN10	✓	✓	✓	
VPM.R150.P351.PN10	✓	✓	✓	✓
VPM.R150.P220.PN16	✓	✓	✓	
VPM.R150.P221.PN16	✓	✓	✓	✓

Calibration report is included.

14.3 Accessories

Accessories

VPA.5000.005	Cable, 5m / 16.4 ft with M12 5pin connector on one side, open wires on other side
VPA.5000.010	Cable, 10m / 32.9 ft with M12 5pin connector on one side, open wires on other side
VPA.0000.200	Power supply (24V, 5pin)
VPA.5004.0005	Ethernet cable, 5m / 16.4 ft with M12 4pin connector on one side, RJ45 on other side
VPA.5004.0105	Ethernet extension cable, 5m / 16.4 ft with M12 4pin female connector on one side, and male on other side
VPA.5004.0001	Compression fitting for VPFlowScope M with integrated safety system
VPA.5004.1001	Locking ring for VPFlowScope M
VPA.5014.003	Explorer case for VPFlowScope M

VPStudio software

VPStudio 4

15 Energy Monitoring Applications

VPFlowScope M can be connected to VPVision. VPVision is the complete real time energy monitoring solution for all utilities within your company. Get real-time data on your usage and see the patterns on your supply and demand side.

Take factual and well-founded decisions on your costs and investments.

Reveal the consumption of all utilities, including compressed air, technical gases, steam, vacuum, natural gas, electricity, wastewater, heating fuels etc.

VPVision enables you to view data on any platform; from PC to smartphone. It will help your organization raise the energy awareness among your staff.

It will be your guiding hand to target energy savings for individuals, teams or at company-wide level.



16 Appendix A - Underwriters Laboratories (UL)

The VPFlowScope M complies with the CE requirements as stated in the CE declaration. CE compliance can only be achieved when grounding and shielding directions are followed and proper cables and connector assemblies are used.



Electrical connection guidelines- UL 508 Listing for USA & Canada (Check label to see if product is UL marked)

The VPFlowScope M is intended to be used with a Class 2 power source or Class 2 transformer in accordance with UL1310 or UL1585. As an alternative a LVLC (Low Voltage Limited Current) power source, with the following properties can be used:

- The device shall be used with a suitable isolating source such that the maximum open circuit voltage potential available to the product is not more than 24 VDC and the current is limited to a value not exceeding 8 amperes measured after 1 minute of operation;
- A fuse in accordance with the UL248 series and rated max 4A, shall be installed in the 24V DC power supply to the device? In order to limit the available current.

Electrical connection guidelines: general remarks

Make sure that the following conditions are met:

- For portable, non-critical applications, a switched mode 14 VDC, 1A power adapter may be used. Switched mode power supplies that are of poor quality, might affect the accuracy.

Le VPFlowscope M est conforme aux exigences CE, comme indiqué dans la déclaration CE. La conformité CE ne peut être atteinte que lorsque les directives de mise à la terre et d'isolation sont suivies et que les câbles et raccords appropriés sont utilisés.



Lignes directrices pour branchements électriques – UL508 pour le Canada et les États-Unis (voir sur l'étiquette si le produit est marqué UL)

Le VPFlowscope M est prévu pour être utilisé avec une source d'alimentation Classe 2 ou avec un transformateur de Classe 2 en accord avec UL1310 ou UL1585. Comme alternative, une source d'alimentation BTCL (Basse Tension Courant Limité) avec les propriétés suivante peut être utilisée :

- Le dispositif doit être utilisé avec une source d'isolation appropriée afin que le voltage maximal en circuit ouvert disponible pour le produit ne dépasse pas 24VDC, et que le courant soit limité à une valeur de 8 ampères après 1 minute de fonctionnement.
- Un fusible de 4A maximum, et conforme à la série UL248 doit être installé dans la source d'alimentation de l'appareil afin de limiter le courant disponible.

Directives pour le raccordement électrique : remarques générales

Assurez-vous que les conditions suivantes sont remplies :

- Pour les applications mobiles, un adaptateur de type alimentation à découpage 14VDC, 1A peut-être utilisée. Cependant, un adaptateur de mauvaise qualité pourra affecter la précision.

17 Appendix B - Federal Communications Commission (FCC) Statement

An FCC grant of equipment authorization and an FCC ID are not required, but the equipment complies with FCC technical requirements.

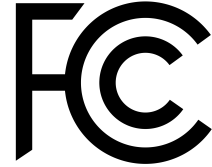

Notes

Notes

energy insights trusted by professionals™

Trido Energy Services

#1425 407 2nd Street SW,
Calgary, AB T2P 2Y3
Canada
info@tridoes.com
+1 (855) 368-7438

MAN-VP-SMPR-EN-2500

Date: 04-04-2025

