

---

# 3-Phase Power Meter

User manual

© 2025 Van Putten Instruments BV



# 3-Phase Power Meter

© 2025 Van Putten Instruments BV

All rights reserved. No parts of this document may be reproduced in any form or by any means - graphic, electronic, or mechanical, including photocopying, recording, taping, or information storage and retrieval systems - without the written permission of the publisher.

Products that are referred to in this document may be either trademarks and/or registered trademarks of the respective owners. The publisher and the author make no claim to these trademarks.

While every precaution has been taken in the preparation of this document, the publisher and the author assume no responsibility for errors or omissions, or for damages resulting from the use of information contained in this document or from the use of programs and source code that may accompany it. In no event shall the publisher and the author be liable for any loss of profit or any other commercial damage caused or alleged to have been caused directly or indirectly by this document.

Last revision date: 15-04-2025 in Delft

## **Publisher**

Van Putten Instruments BV  
Marlotlaan 1G  
2614 GV Delft  
The Netherlands

---



## Table of Contents

<b>1 Warning - Read this first</b>	<b>5</b>
<b>2 Introduction</b>	<b>6</b>
<b>3 Product overview</b>	<b>7</b>
<b>4 Quick start</b>	<b>10</b>
<b>5 Measurement</b>	<b>13</b>
<b>6 Installation</b>	<b>14</b>
<b>1 Electrical connection</b>	<b>14</b>
Single phase two wire with neutral	14
Single phase three wire	14
Single phase two wire without neutral	15
Three phase four wire	15
Three phase three wire delta without neutral	16
Grounded leg service	16
<b>2 Mechanical installation</b>	<b>17</b>
<b>3 Selecting Current Transformers</b>	<b>18</b>
<b>4 Connecting Current Transformers</b>	<b>19</b>
<b>5 Circuit protection</b>	<b>20</b>
<b>6 Connecting voltage terminals</b>	<b>20</b>
<b>7 Connectivity &amp; communication</b>	<b>21</b>
<b>1 Modbus</b>	<b>21</b>
Wiring	22
Communication diagnostics	24
Registers	26
Basic registers	27
Advanced register	30
Configuration register list	36
Communication register list	41
Diagnostic register list	42
<b>2 Diagnostic LEDs</b>	<b>43</b>
<b>3 Current Transformers</b>	<b>47</b>
<b>8 Specification</b>	<b>48</b>
<b>9 Order information and accessories</b>	<b>51</b>
<b>10 Energy Monitoring Applications</b>	<b>52</b>
<b>11 Appendix A - Federal Communications     Commission (FCC) Statement</b>	<b>53</b>

---

<b>12 Appendix B - Measurement troubleshooting</b>	<b>54</b>
<b>13 Appendix C - Maintenance</b>	<b>56</b>

# 1 Warning - Read this first

	<ol style="list-style-type: none"><li>1. Only qualified personnel or licensed electricians should install the meter. The mains voltages of 120 Vac to 600 Vac can be lethal!</li><li>2. Only specially trained and qualified or licensed electricians should install this meter in a medium voltage (&gt; 600Vac) system.</li><li>3. Follow all applicable local and national electrical and safety codes.</li><li>4. Install the meter in an electrical enclosure (panel or junction box) or in a limited access electrical room.</li><li>5. Verify that circuit voltages and currents are within the proper range for the meter model.</li><li>6. Use only current transformers (CTs) with built-in burden resistors, that generate 0.333 Vac (333 millivolts AC) at rated current. Do not use current output (ratio) CTs such as 1 amp or 5 amp output CTs: they will destroy the meter and may create a shock hazard. See <a href="#">Current Transformers</a> for CT maximum input current ratings.</li><li>7. Ensure that the line voltage inputs to the meter are protected by fuses or circuit breakers (not needed for the neutral wire). See <a href="#">Circuit Protection</a> for details.</li><li>8. Equipment must be disconnected from the HAZARDOUS LIVE voltages before access.</li><li>9. The terminal block screws are not insulated. Do not contact metal tools to the screw terminals if the circuit is live!</li><li>10. Do not place more than one line voltage wire in a screw terminal; use wire nuts instead.</li><li>11. Before applying power, check that all the wires are securely installed by tugging on each wire.</li><li>12. Do not install the meter where it may be exposed to temperatures below <math>-30^{\circ}\text{C}</math> or above <math>55^{\circ}\text{C}</math>, excessive moisture, dust, salt spray, or other contamination. The meter requires an environment no worse than pollution degree 2 (normally only non-conductive pollution; occasionally, a temporary conductivity caused by condensation must be expected).</li><li>13. Do not drill mounting holes using the meter as a guide; the drill chuck can damage the screw terminals and metal shavings can fall into the connectors, causing an arc risk.</li><li>14. If the meter is installed incorrectly, the safety protections may be impaired.</li></ol>
	<p><b>Feedback leads to product improvement.</b> Please share your experience with us, as we are continuously improving our products in our commitment to quality, reliability and ease of use. Let us know via <a href="mailto:sales@vpinstruments.com">sales@vpinstruments.com</a>!</p>

## 2 Introduction

Congratulations on your purchase of the 3-Phase Power Meter - Wide-Range Modbus.

This meter offers precision energy and power measurements in a compact package. It enables you to make power and energy measurements within existing electric service panels avoiding the costly installation of subpanels and associated wiring. It is designed for use in demand side management, sub-metering, and energy monitoring applications. The meter communicates on an RS485 two-wire bus using the Modbus protocol. The one model covers all applications including single-phase, three-phase wye, and three-phase delta configurations for nominal voltages from 100 VAC to 600 VAC at 50 and 60 Hz. The meter is self-powered from the mains connection. In addition to low voltage applications, the meter can be used in medium voltage applications (normally 2300 Vac and 4160 Vac) because potential transformer (PT) ratio scaling is available.

This meter is fully configurable remotely via Modbus.

Great products deserve great user manuals. We have done our best to make this user manual as complete as possible. New users, please read it carefully to familiarize yourself with our products. Experienced users can check out the [Quick start chapter](#).

Check the packaging box for any inconsistencies. Should there be any shipping damage, notify the local carrier. At the same time a report should be submitted to Van Putten Instruments BV, Marlotlaan 1G, 2614 GV DELFT, The Netherlands.

**This manual is dedicated to:**  
VPA.8000.WRMB

For technical questions or support inquiries, please contact us by email at [support@vpinstruments.com](mailto:support@vpinstruments.com).

### 3 Product overview

This one meter can be used for the following configurations:

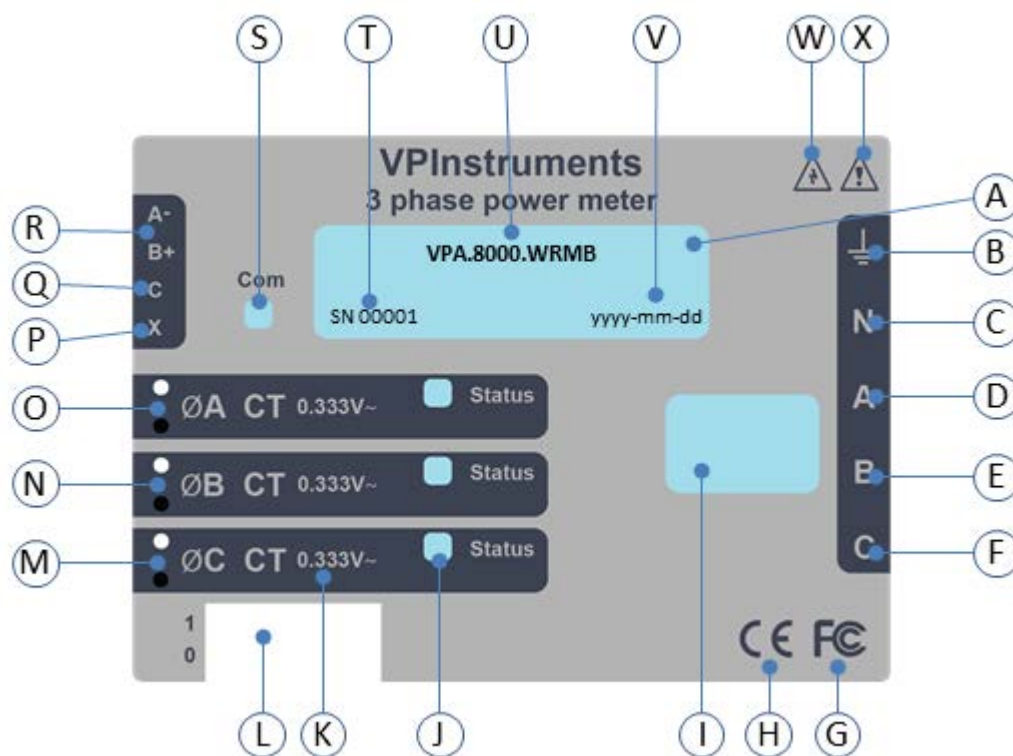

L to L voltage	L to N voltage	Type	Electrical service types
208, 240	120	Wye	1-Phase, 2-wire 120V with neutral 1-Phase, 3-wire 120V / 240V with neutral 3-Phase, 4-wire 120V / 208V with neutral
208	N/A	Delta	3-Phase, 3-wire 208V (no neutral)
480	277	Wye	3-Phase, 4-wire 277V / 480V with neutral
480	N/A	Delta	3-Phase, 3-wire 480V (no neutral)
600	347	Wye	3-Phase, 4-wire 347V / 600V with neutral
600	N/A	Delta	3-Phase, 3-wire 600V (no neutral)

The wire count does NOT include ground. It only includes neutral (if present) and phase wires.



A	Product information window. Contains product code, production date and serial number.
B	Functional ground. This terminal should be connected to earth ground if possible. It is not required for safety grounding, but ensures maximum meter accuracy.
C	Neutral. This terminal "N" should be connected to neutral when available.
D, E, F	Line voltage inputs. These terminals connect to the ØA (phase A), ØB (phase B), and ØC (phase C) electric mains. On wye models the meter is powered from the ØA and N terminals. On delta models, the meter is powered from the ØA and ØB terminals.
G	FCC Mark. This logo indicates that the meter complies with part 15 of the FCC rules.
H	CE Marking
I	Line voltage measurement ratings. See the <a href="#">Specifications</a> for more information about the measurement voltage and category.
J	Status LEDs. These are status LEDs used to verify and diagnose meter operation. See <a href="#">Diagnostic LEDs</a> for details.
K	Current Transformer (CT) voltage rating. These markings "0.333V~" indicate that the meter must be used with CTs that generate a full-scale output of 0.333 Vac (333 millivolts).
L	DIP switch. This DIP switch block is used to set the Modbus address and baud rate. See <a href="#">Modbus</a> .
M, N, O	Current Transformer (CT) inputs. These indicate CT screw terminals. Note the white and black circles at the left edge of the label: these indicate the color of the CT wire that should be inserted into the corresponding screw terminal. The terminals marked with black circles are connected together internally.
P	Auxiliary output terminal.
Q	Modbus common terminal. This is the common or ground terminal for Modbus RS485 communication wiring.
R	Modbus signal terminals. These are the RS485 A- and B+ signals (half-duplex, two-wire). There are several names for these terminals: <ul style="list-style-type: none"> <li>• Inverting pin: A-, A, -, TxD-, RxD-, D0, and "B"</li> <li>• Non-inverting pin: B+, B, +, TxD+, RxD+, D1, and "A"</li> </ul>
S	Communication status. This LED indicates communication status. See <a href="#">Communication diagnostics</a> for details.
T	Serial number. This shows meter serial number and options if any are selected. The barcode contains the serial number in Code 128C format.
U	Model number.
V	Manufacture date. This is the date of manufacture for this meter.
W	Caution, risk of electrical shock. This symbol indicates that there is a risk of electric shock when installing and operating the meter if the installation instructions are not followed correctly.
X	Attention - consult Manual. This symbol indicates that there can be danger when installing and operating the meter if the installation instructions are not followed correctly.

**Symbols**

	Attention - consult installation and operation manual	Read, understand, and follow all instructions in this Installation and Operation Manual including all warnings, cautions, and precautions before installing and using the product.
	Caution – risk of electrical shock	Potential shock hazard from dangerous high voltage.
	CE marking	Complies with the regulations of the European Union for Product Safety and Electro-Magnetic Compatibility. <ul style="list-style-type: none"><li>• Low Voltage Directive – EN 61010-1: 2001</li><li>• EMC Directive – EN 61327: 1997 + A1/1998 + A2/2001</li></ul>

## 4 Quick start

To set up the Current Transformer (CT) ratio and other parameters using Modbus RTU, follow these instructions.

### The following items are needed to set up a power meter:

1. A computer and Modpoll software. (see section D for a download link).
2. An ATC RS485 to USB converter with D sub 9 to screw terminal connection (part of the JB5 communications kit (VPA.5001.205).
3. Three wire cable to connect to Modbus to "A-" and "B +" and ground (common connection "C" on the power meter).
4. Power cable with unterminated leads on one end. The power cable wall plug end will depend on the voltage and available power outlet design and can be used for 120Vac and 230Vac.
5. A small Phillips and a small flat blade screwdriver.

### Procedure to set the CT ratio

#### A. Initial power up of the meter:

1. Make sure the power is off (i.e. that the plug has not been inserted into the power outlet).
2. Connect the yellow/green wire to the safety ground  $\equiv$  terminal (right side in the picture).
3. Connect the "hot" lead to "A" on the power meter (right side in the picture).
4. Connect the "neutral" lead to "N" on the power meter (right side in the picture).
5. Interconnect "neutral" lead to "B" on the power meter (right side in the picture).
6. Turn on the power by plugging in the power plug into the power outlet. Verify that the status LEDs on the power meter are on.
7. Turn off the power to the meter before continuing with the Modbus wire connections.

#### B. Modbus wiring connections:

1. Set the DIP switches on the power meter for Modbus address 1 (Position 1 set to ON. All other positions set to OFF. – This sets the Modbus address to "1" and sets the baud rate to 9600, 8 data bits, no parity and one stop bit).
2. Connect the terminal strip that is part of the JB5 Kit to the ATC Modbus RTU to USB converter.
3. Connect the 3-wire Modbus cable as follows:

Signal Designation	Terminal Strip (ATC converter)	Power Meter (upper left side)
Modbus RS485 A	485 -	A -
Modbus RS485 B	485 +	B +
Modbus Common	GND	C



**C. Determine the COM port that the ATC convert is using:**

1. Windows: Open the Device Manager.
2. Look at Ports (COM & LPT). Note the active COM ports.
3. Plug the USB connector of ATC Modbus RTU to USB converter into a USB port on the computer. (You should hear a beep when the COM port activates.)
4. If the COM port that appears when you plug in the ATC Modbus RTU to USB converter is  $\geq 10$ , change it to a COM port between 1 and 9. To change the COM port, click "port settings" choose "advanced" select a new (unused) port number between 1 and 9 and overwrite the port number.
5. Unplug the USB connector and note which COM port disappears (That is the COM port that will be used with Modpoll).
6. If a COM port does not appear when plugging in the USB connector, download and install driver "VPFlowScope RS485 converter driver (ATC-RS485)" from <https://www.vpinstruments.com/downloads>

Note for the purpose of these instructions, COM9 is specified. Change it to the COM port that is correct for your computer per section C of these instructions.

**D. Set up Modpoll and communicate with the power meter:**

1. Download Modpoll from <https://www.modbusdriver.com/modpoll.html>.
2. Plug the USB connector of the ATC Modbus RTU to USB converter into the USB port on the computer.
3. Open the Command Prompt window.
4. Move a copy of modpoll.exe into the directory that is in the Command Prompt window (using Windows Explorer).
5. Apply voltage to the power meter (per section A) and verify that the power meter status LED's are on.
6. Read register 1603 using the following command line in the Command window:  
**Modpoll -m rtu -a 1 -r1603 -t4 -b9600 -p none COM9**
7. A value of 5 should be returned. (5 is for a CT ratio of 5A to 0.333Vac)
8. Use Control-C to stop the flow of returned data.

**E. Write the CT ratio to the power meter:**

1. Apply power to the power meter.
2. Write a CT value to register 1603. Writing to this register will put the same CT value in all three registers (for phases A, B and C). The typical values are 100A, 400A, 1000A or 1500A. Other values are possible depending on which CTs are used and how the CTs are physically used. The following command line writes 400 (for a 400A CT) to register 1603:  
**Modpoll -m rtu -a 1 -r1603 -t4 -b9600 -p none COM9 400**
3. Read Register 1603 again to verify that it returns 400:  
**Modpoll -m rtu -a 1 -r1603 -t4 -b9600 -p none COM9**
4. Remove power from the power meter.

**F. Set the CT ratio on each power meter by repeating step E.**

**G. Set a unique Modbus address for meters on the same Modbus daisy chain:**

1. Remove power to the power meter when setting the Modbus address.
2. Use the DIP switches to set a unique Modbus address on each meter that is on a daisy chain. See "Setting the Modbus Address in section 7.1.

**Basic configuration**

If you are planning on using demand measurements and you don't want to use the default 15 minute interval, you should set the [DemPerMins](#) as well.

**Verify operation**

You should be able to read several registers to check that the meter is correctly installed and measuring power and energy. If your Modbus software supports floating point Modbus registers, you may want to read from the set [Basic Register List](#) - Floating Point. If you cannot easily read floating point values, use [Basic Register List](#) - Integer instead. Verify registers in the following sequence:

- Freq (power line frequency): should be near 50 or 60 Hz (or 500 or 600 if you are reading the integer registers).
- VoltA, VoltB, VoltC: should match your line-to-neutral voltage.
- PowerA, PowerB, PowerC: should be positive (unless you are measuring something that can generate power like a PV system) and in a reasonable range for the load being measured (make sure your load is ON). Note: the integer power registers are scaled, so if you expect to see 75,000 W (75 kW) and instead you see 7500, that is probably because the meter is reporting integer power in 10 W increments. See PowerIntScale for details.
- ErrorStatus: this will return 0 if there are no errors. If you see any non-zero values, write them down and check the [Diagnostic Registers](#) section below to determine the problem. If you are measuring floating point values and the numbers are way off, your software may be combining the floating point registers in the wrong order. Compare the values to the integer registers and check to see if your software has an option like "Float - swapped" or "Float - reversed"; if so, see if this fixes the problem.
- If you don't get reasonable results, check [Appendix B - Measurement Troubleshooting](#).

## 5 Measurement

The 3-Phase Power Meter measures the following:

- True RMS Power - Watts (Phase A, Phase B, Phase C, Sum)
- Reactive Power - VARs (Phase A, Phase B, Phase C, Sum)
- Power Factor (Phase A, Phase B, Phase C, Average)
- True RMS Energy - Watthours (Phase A, Phase B, Phase C, Sum)
- Reactive Energy - VAR-hours (Sum)
- AC Frequency
- RMS Voltage (Phase A, Phase B, Phase C)
- RMS Current (Phase A, Phase B, Phase C)
- Demand and Peak Demand

One 3-Phase Power Meter can measure up to three different “single-phase two-wire with neutral” branch circuits from the same service by separately monitoring the phase A, B, and C values. You can use a different CT with a different amperage rating on each of the circuits.

### Measurement overview

The meter performs measurements every one second. The measurements are used to update three types of registers:

- Energy registers: These accumulate up (or sometimes down) based on the consumed energy during each measurement period. Energy values are preserved across power failures.
- Instantaneous registers: These are non-accumulating values, like power, volts, current, etc. These are not preserved across power failures.
- Demand registers: these accumulate data from each measurement, but the reported demand values only update at the completion of a demand interval (or subinterval), which is typically every 15 minutes. Only the peak demand values are preserved across power failures.

## 6 Installation

### Summary

1. Mount the meter.
2. Turn off power before installing solid-core (non-opening) CTs or making voltage connections.
3. Mount the CTs around the line voltage conductors being measured. Take care to orient the CTs facing the source of power.
4. Connect the twisted white and black wires from the CT to the six position black terminal block on the meter, matching the wire colors to the white and black dots on the front label.
5. Connect the voltage wires including ground and neutral (if present) to the green terminal block, and check that the current (CT) phases match the voltage measurement phases.
6. Set the Modbus network address and baud rate with the DIP switches.
7. Connect the output terminals of the meter to the monitoring equipment.
8. Apply power to the meter.
9. Verify that the LEDs light correctly and don't indicate an error condition.

Please find detailed instructions below.

### 6.1 Electrical connection

#### 6.1.1 Single phase two wire with neutral

This configuration is most often seen in homes and offices. The two conductors are neutral and line. The meter is powered by the VA and VB terminals, so you must connect the neutral wire, L2, or L3 to the VB terminal to power the meter.

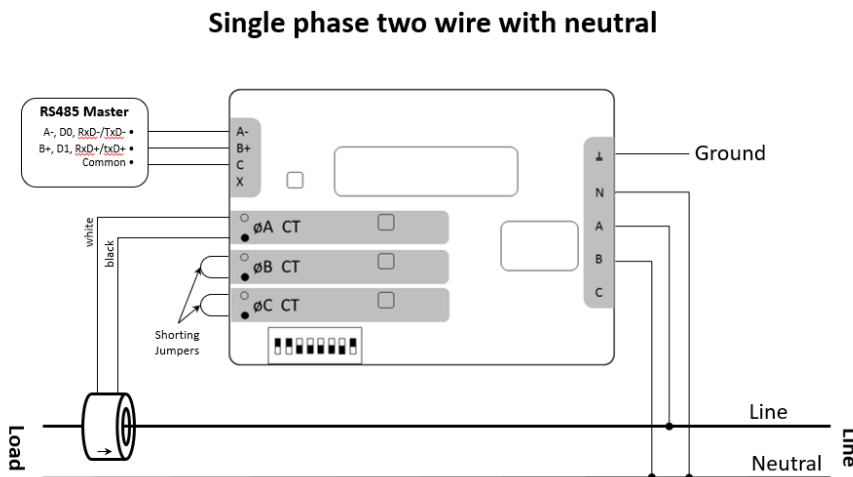

#### 6.1.2 Single phase three wire

This configuration is seen in North American residential and commercial service with 240 Vac for large appliances. The three conductors are a mid-point neutral and two line voltage wires with AC waveforms 180° out of phase; this results in 120 Vac between either line conductors (phase) and neutral, and 240 Vac (or sometimes 208 Vac) between the two line conductors (phases).

### Single phase three wire (mid-point neutral)

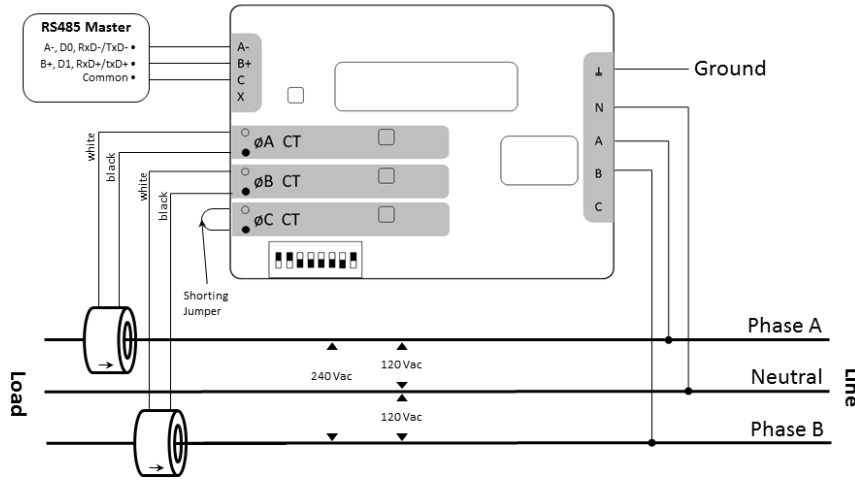

### 6.1.3 Single phase two wire without neutral

This is seen in residential and commercial service with 208 to 240 Vac for large appliances. The two conductors have AC waveforms  $120^\circ$  or  $180^\circ$  out of phase. Neutral is not used. For this configuration, the meter is powered from  $V_A$  and  $V_B$  (phase A and phase B) terminals.

For best accuracy, we recommend connecting the N (neutral) terminal to the ground terminal. This will not cause ground current to flow because the neutral terminal does not power the meter.

### Single phase two wire without neutral

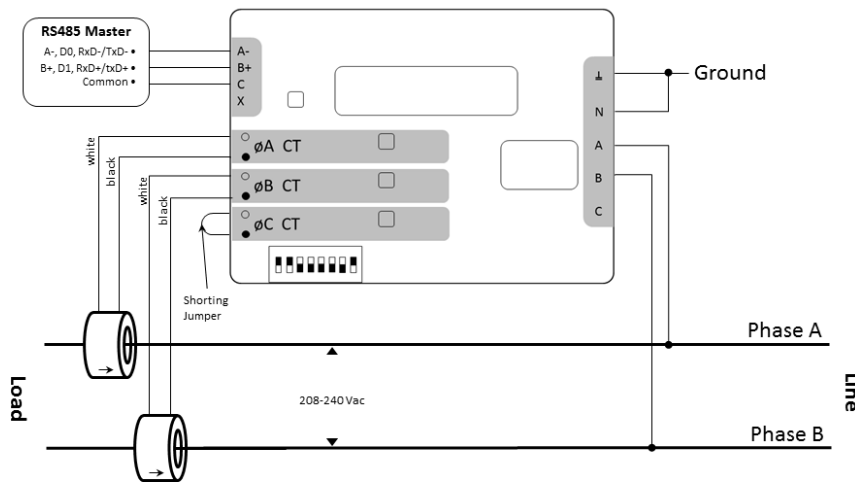

### 6.1.4 Three phase four wire

This is typically seen in commercial and industrial environments. The conductors are neutral and three power lines with AC waveforms shifted  $120^\circ$  between phases. The line voltage conductors may be connected to the  $V_A$ ,  $V_B$ , and  $V_C$  terminals in any order, so long as the CTs are connected to matching phases. It is important that you connect N (neutral) for accurate measurements.

### Three phase four wire

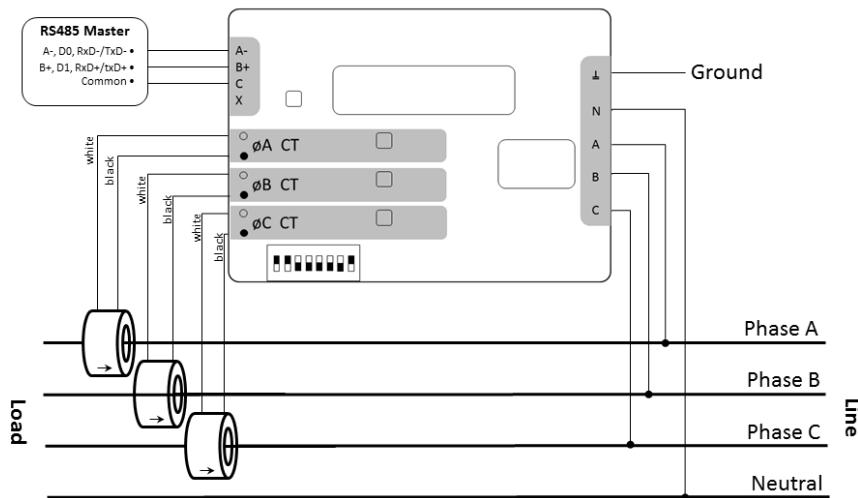

#### 6.1.5 Three phase three wire delta without neutral

This is typically seen in manufacturing and industrial environments. There is no neutral wire, just three power lines with AC waveforms shifted  $120^\circ$  between the successive phases. With this configuration, the line voltage wires may be connected to the  $V_A$ ,  $V_B$ , and  $V_C$  terminals in any order, so long as the CTs are connected to matching phases.

For best accuracy, we recommend connecting the N (neutral) terminal to earth ground. This will not cause ground current to flow because the neutral terminal is not used to power the meter.

#### Three phase three wire delta without neutral

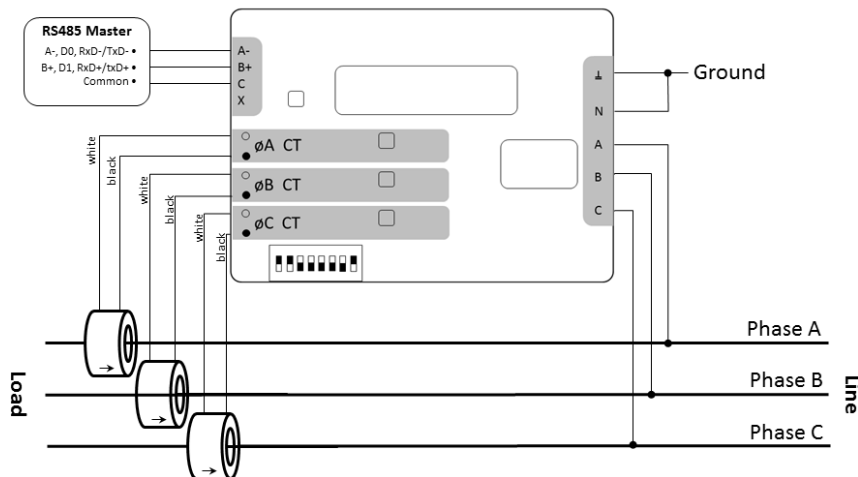

#### 6.1.6 Grounded leg service

In rare cases with delta services or single-phase two-wire services without neutral, one of the phases may be grounded. You can check for this by using a multimeter to measure the voltage between each phase and ground. If you see a reading between 0 and 5 Vac, that leg is probably grounded (sometimes called a "grounded delta").

The meter will correctly measure services with a grounded leg, but the measured voltage and power for the grounded phase will be zero and the status LED will not light for whichever phase is grounded, because

the voltage is near zero. Also, one or both of the active (non-grounded) phases may indicate low power factor because this type of service results in unusual power factors.

For optimum accuracy with a grounded leg, you should also connect the N (neutral) terminal on the meter to the ground terminal; this will not cause any ground current to flow because the neutral terminal is not used to power the meter. If you have a grounded leg configuration, you can save money by removing the CT for the grounded phase, since all the power will be measured on the non-grounded phases.

We recommend putting the grounded leg on the  $V_B$  or  $V_C$  inputs and attaching a note to the meter indicating this configuration for future reference.

## 6.2 Mechanical installation

Protect the meter from moisture, direct sunlight, high temperatures, and conductive pollution (salt spray, metal dust, etc.) If moisture or conductive pollution may be present, use an IP 66 or NEMA 4 rated enclosure to protect the meter. Due to its exposed screw terminals, the meter must be installed in an electrical service panel, an enclosure, or an electrical room. The meter may be installed in any orientation, directly to a wall of an electrical panel or junction box

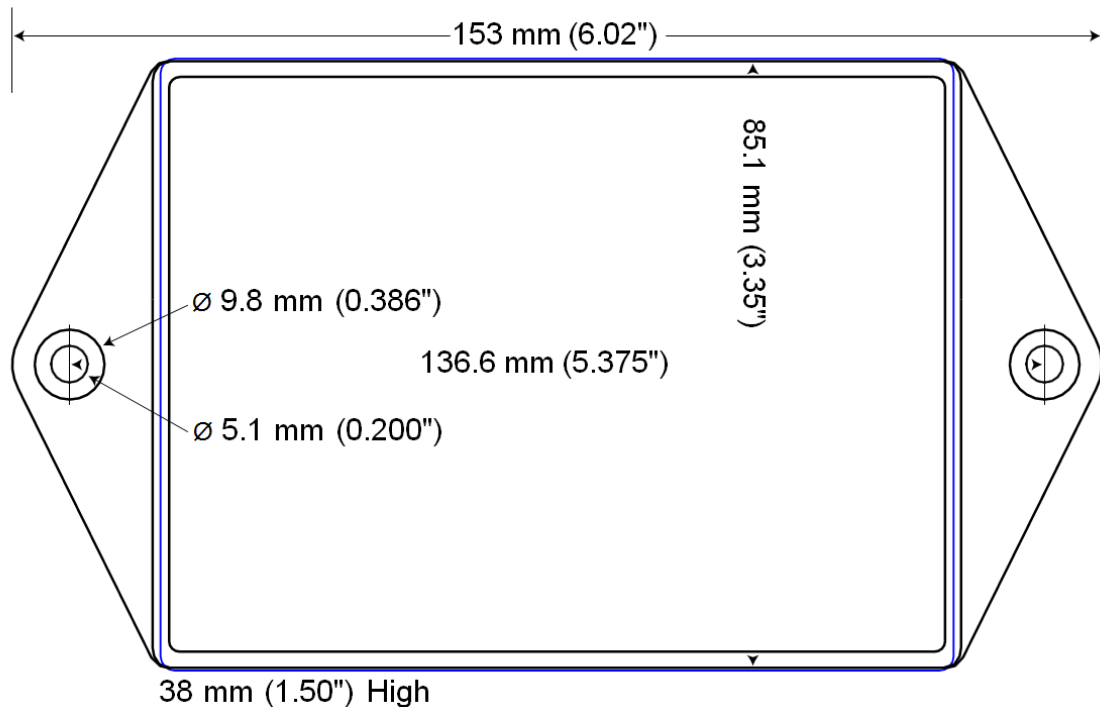

The meter has two mounting holes spaced 5.375 inches (137 mm) apart (center to center). These mounting holes are normally obscured by the detachable screw terminals. Remove the screw terminals by pulling outward while rocking from end to end. The meter may be used as a template to mark mounting hole positions, but do not drill the holes with the meter in the mounting position because the drill may damage the connectors and leave drill shavings in the connectors.

You may mount the meter with the supplied #8 self-tapping sheet metal screws using 1/8 inch pilot hole (3.2 mm). If you use screws, avoid over-tightening which can crack the case. If you don't use the supplied screws, the following sizes should work (bold are preferred); use washers if the screws could pull through the mounting holes

Screw style	U.S.A. UTS sizes	Metric sizes
Pan Head or Round Head	#6, #8, #10	M3.5, M4, M5
Truss Head	#6, #8	M3.5, M4
Hex Washer Head (integrated washer)	#6, #8	M3.5, M4
Hex Head (add washer)	#6, #8, #10	M3.5, M4, M5

## 6.3 Selecting Current Transformers

The rated full-scale current of the CTs should normally be chosen somewhat above the maximum current of the circuit being measured (see Current Crest Factor below for more details). In some cases, you might select CTs with a lower rated current to optimize accuracy at lower current readings. Take care that the maximum allowable current for the CT can not be exceeded without tripping a circuit breaker or fuse; see [Current Transformers](#).

We only offer CTs that measure AC current, not DC current. Significant DC current can saturate the CT magnetic core, reducing the AC accuracy. Most loads only have AC current, but some rare loads draw DC current, which can cause measurement errors.

CTs can measure lower currents than they were designed for by passing the wire through the CT more than once. For example, to measure currents up to 1 amp with a 5 amp CT, loop the wire through the CT five times. The CT is now effectively a 1 amp CT instead of a 5 amp CT. The effective current rating of the CT is the labelled rating divided by the number of times that the wire passes through the CT.

If you are using the measurement phases of the meter (ØA, ØB, and ØC) to measure different circuits, you can use CTs with different rated current on the different phases. Instead of setting one CtAmps value for all phases, you can use different values for each phase: CtAmpsA, CtAmpsB, and CtAmpsC.

### Current Crest Factor

The term “current crest factor” is used to describe the ratio of the peak current to the RMS current (the RMS current is the value reported by multimeters and the meter). Resistive loads like heaters and incandescent lights have nearly sinusoidal current waveforms with a crest factor near 1.4. Power factor corrected loads such as electronic lighting ballasts and computer power supplies typically have a crest factor of 1.4 to 1.5. Battery chargers, VFD motor controls, and other nonlinear loads can have current crest factors ranging from 2.0 to 3.0, and even higher.

High current crest factors are usually not an issue when metering whole building loads, but can be a concern when metering individual loads with high current crest factors. If the peak current is too high, the meter’s CT inputs can clip, causing inaccurate readings.

This means that when measuring loads with high current crest factors, you may want to be conservative in selecting the CT rated current. For example, if your load draws 10 amps RMS, but has a crest factor of 3.0, then the peak current is 30 amps. If you use a 15 amp CT, the meter will not be able to accurately measure the 30 amp peak current. Note: this is a limitation of the meter measurement circuitry, not the CT.

The following graph shows the maximum RMS current for accurate measurements as a function of the current waveform crest factor. The current is shown as a percentage of CT rated current. For example, if you have a 10 amp load with a crest factor of 2.0, the maximum CT current is approximately 85%. Eighty-five percent of 15 amps is 12.75, which is higher than 10 amps, so your measurements should be accurate. On the other hand, if you have a 40 amp load with a crest factor of 4.0, the maximum CT current is 42%. Forty-two percent of a 100 amp CT is 42 amps, so you would need a 100 amp CT to accurately measure this 40 amp load.

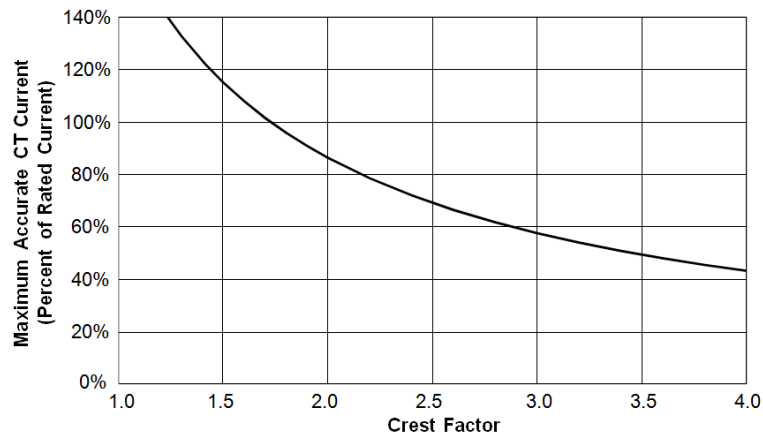

You frequently won't know the crest factor for your load. In this case, it's generally safe to assume the crest factor will fall in the 1.4 to 2.5 range and select CTs with a rated current roughly 150% of the expected RMS current. So if you expect to be measuring currents up to 30 amps, select a 50 amp CT.

## 6.4 Connecting Current Transformers

- Use only current transformers (CTs) with built-in burden resistors that generate 0.33333 Vac (333.33 millivolts AC) at rated current. See [Current Transformers](#) for the maximum input current ratings.
- Do not use ratio (current output) CTs such as 1 amp or 5 amp output CTs: they will destroy the meter and present a shock hazard! These are commonly labelled with a ratio like 100:5.
- Find the arrow or label "THIS SIDE TOWARD SOURCE" on the CT and face toward the current source: generally the utility meter or the circuit breaker for branch circuits. If CTs are mounted backwards or with their white and black wires reversed the measured power will be negative. The diagnostic LEDs indicates negative power with flashing red LEDs.
- Be careful to match up the current transformers to the voltage phases being measured. Make sure the  $V_A$  CT is measuring the line voltage connected to  $V_A$ , and the same for phases B and C. Use the supplied colored labels or tape to identify the wires. It is possible, using Modbus, to remotely reassign a CT to a different phase voltage if an error has been made.
- To prevent magnetic interference, the CTs on different phases should be separated by 1 inch (25 mm). The line voltage conductors for each phase should be separated by at least 1 inch (25 mm) from each other and from neutral.
- For best accuracy, the CT opening should not be much larger than the conductor. If the CT opening is much larger, position the conductor in the center of the CT opening.
- Because CT signals are susceptible to interference, we recommend keeping the CT wires short and cutting off any excess length. It is generally better to install the meter near the line voltage conductors instead of extending the CT wires. However, you may extend the CT wires by 300 feet (100 m) or more by using shielded twisted-pair cable and by running the CT wires away from high current and line voltage conductors.
- OPTIONAL: if you see spurious readings on unused phases, jumper the unused CT inputs.

To connect CTs, pass the wire to be measured through the CT and connect the CT to the meter. Always remove power before disconnecting any live wires. Put the line conductors through the CTs as shown in the section [Electrical connection](#). You may measure generated power by treating the generator as the source.

For solid-core CTs, disconnect the line voltage conductor to install it through the CT opening.

Split-core and bus-bar CTs can be opened for installation around a wire by pulling the removable section straight away from the rest of the CT or unhooking the latch; it may require a strong pull. Some CT models include thumb-screws to secure the opening. The removable section may fit only one way, so match up the steel core pieces when closing the CT. If the CT seems to jam and will not close, the steel core pieces are probably not aligned correctly; DO NOT FORCE together. Instead, reposition or rock the removable portion until the CT closes without excessive force. A nylon cable tie can be secured around the CT to prevent inadvertent opening.

Some split-core CT models have flat mating surfaces. When installing this type of CT, make sure that mating surfaces are clean. Any debris between the mating surfaces will increase the gap, decreasing accuracy.

Next, connect the CT lead wires to the meter terminals labelled CT1, CT2, and CT3. Route the twisted black and white wires from the CT to the meter. We recommend cutting off any excess length to reduce the risk of interference. Strip 1/4 inch (6 mm) of insulation off the ends of the CT leads and connect to the six position black screw terminal block. Connect each CT lead with the white wire aligned with the white dot on the label, and the black wire aligned with the black dot. Note the order in which the phases are connected, as the voltage phases must match the current phases for accurate power measurement.

Finally record the CT rated current as part of the installation record for each meter. If the conductors being measured are passed through the CTs more than once, then the recorded rated CT current is divided by the number of times that the conductor passes through the CT.

## 6.5 Circuit protection

The meter is considered “permanently connected equipment”, because it does not use a conventional power cord that can be easily unplugged. Permanently connected equipment must have overcurrent protection and be installed with a means to disconnect the equipment.

- A switch, disconnect, or circuit breaker may be used to disconnect the meter and must be as close as practical to the meter. If a switch or disconnect is used, then there must also be a fuse or circuit breaker of appropriate rating protecting the meter.
- Meters only draw 10-30 milliamps; VPIInstruments recommends using circuit breakers or fuses rated for between 0.5 amps and 20 amps and rated for the line voltages and the current interrupting rating required.
- The circuit breakers or fuses must protect the ungrounded supply conductors (the terminals labelled ØA, ØB, and ØC). If neutral is also protected (this is rare), then the overcurrent protection device must interrupt neutral and the supply conductors simultaneously.
- Any switches or disconnects should have at least a 1 amp rating and must be rated for the line voltages.
- The circuit protection / disconnect system must meet IEC 60947-1 and IEC 60947-3, as well as all national and local electrical codes.
- The line voltage connections should be made with wire rated for use in a service panel or junction box with a voltage rating sufficient for the highest voltage present. VPIInstruments recommends 14 or 12 AWG (1.5 mm<sup>2</sup> or 2.5 mm<sup>2</sup>) stranded wire, rated for 600 volts. Solid wire may be used, but must be routed carefully to avoid putting excessive stress on the screw terminal.
- The meter has an earth connection, which should be connected for maximum accuracy. However, this earth connection is not used for safety (protective) earthing.

## 6.6 Connecting voltage terminals

Always turn off or disconnect power before connecting the voltage inputs to the meter. Connect each phase voltage to the appropriate input on the green terminal block; also connect ground and neutral (if required). The voltage inputs to the meter do not need to be powered from the same branch circuit as the load being monitored. In other words, if you have a three-phase panel with a 100 A three-pole breaker powering a motor that you wish to monitor, you can power the meter (or several meters) from a separate 20 A three-pole breaker installed in the same, or even adjacent panel, so long as the load and voltage connections are supplied from the same electric service.

The green screw terminals handle wire up to 12 AWG (2.5 mm<sup>2</sup>). Strip the wires to expose 1/4" (6 mm) of bare copper. When wiring the meter, do not put more than one wire under a screw. If you need to distribute power to other meters, use wire nuts or a power distribution block. The section [Electrical connection](#) shows the proper connections for the power meter and electrical services. Verify that the voltage line phases match the CT phases.

If there is any doubt that the meter voltage rating is correct for the circuit being measured, unplug the green terminal block (to protect the meter), turn on the power, and use a voltmeter to compare the voltages (probe the terminal block screws) to the values in the white box on the meter front label. After testing, plug in the terminal block, making sure that is pushed in all the way.

For best accuracy, always connect the  $V_N$  (neutral) terminal on the meter. If you are using a delta configuration and the circuit has no neutral, then jumper the earth ground to the  $V_N$  (neutral) terminal.

When power is first applied to the meter, check that the LEDs behave normally (see Installation LED Diagnostics below): if you see the LEDs flashing red-green-red-green, then disconnect the power immediately! This indicates the line voltage is too high for this model.

## 7 Connectivity & communication

### 7.1 Modbus

#### Introduction to Modbus

The meter uses Modbus RTU communication. A complete introduction on the Modbus standard can be found on [www.modbus.org](http://www.modbus.org). See the document [Modbus\\_over\\_serial\\_line\\_V1\\_02.pdf](#), which can be downloaded from their website. We strongly recommend to download and read this information carefully before installing Modbus communication. The following paragraphs in this chapter assume you are familiar with the Modbus communication standard.

The Modbus protocol is a leader/follower protocol, with only one master and many slaves. The meter is always a slave device, and responds only when queried.

#### Modbus functions

In most cases, your Modbus software will automatically use the correct Modbus command for any action you wish to perform, so you may be able to skip this section. The Modbus specifications list numerous possible commands, but the meter only supports the following:

- 03 (0x03) - Read Holding Registers: Holding registers can be read and written and are intended for configuration values, but the meter treats input registers and holding registers interchangeably, so you can use functions 04 or 03 to read any registers.
- 04 (0x04) - Read Input Registers: Input registers are generally read-only and report power, energy, and related values. The meter treats input registers and holding registers as interchangeable, so you can use functions 04 or 03 to read any registers.
- 06 (0x06) - Write Single Register: This writes a new value to a single register.
- 16 (0x10) - Write Multiple Registers: This writes a new value to a range of registers.

Other functions will result in Modbus exception 01 - Illegal Function Code.

#### Baud rates

The standard baud rates are 9,600 and 19,200 baud, and rates from 1,200 to 38,400 baud can be configured by writing to the communication registers.

#### Communication parameters

The communication always uses 8 data bits and one stop bit. The parity defaults to none but can be changed to even by writing to the communication registers.

Specification	
Baud Rates	1200, 2400, 4800, 9600, 19200, 38400
Duplex	Half (two-wire plus common)
Polarity Auto-detect	Will automatically correct swapped A- and B+ terminals provided network has at least 200 millivolt bias between A- and B+
Parity:	Standard: N81 (no parity, eight data bits, one stop bit) Configurable: E81 (even parity, eight data bits, one stop bit)
Modbus Buffer	256 bytes
Communication Response Time	5 - 25 milliseconds (may be longer immediately after a Modbus write command while values are saved to non-volatile memory)
<b>RS485 interface</b>	
RS485 Output Isolation	4500 Vac RMS
Driver Output Voltage (Open Circuit)	±6 Vdc maximum Driver Output Voltage (54 load): ±1.5 Vdc minimum Driver Output Current (54 load): ±60 mA typical

Driver Output Rise Time	(54    50 pF load): 900 nS typical
Receiver Common-Mode Voltage Range	-7 Vdc to +12 Vdc maximum
Receiver Sensitivity	±200 mV
Receiver Bus Load:	1/8 unit load (up to 256 meters per subnet)
Receiver Failsafe Modes	Bus open, bus shorted, bus idle

### Setting the Modbus address

Every device on a Modbus network must have a unique address and the correct baud rate. The meter sets the address and baud rate with an eight position DIP switch.

The meter supports Modbus addresses from 1 to 63 using the DIP switch. Address 0 is used for broadcast messages and is not a valid address. As shipped from the factory, the meter will be configured with an address of 0, which is invalid and will prevent any communication and cause the "Com" LED to light solid red.

Set the Modbus address by switching DIP switch positions 1-6, each of which adds a different value to the address. The change will take effect immediately.

Dip switch values						
DIP Switch	1	2	3	4	5	6
Up (1) Value	1	2	4	8	16	32

Address examples						
1	Up	Down	Down	Down	Down	Down
1+2+4 = 7	Up	Up	Up	Down	Down	Down
4+16 = 20	Down	Down	Up	Down	Up	Down
1+2+16+32 = 51	Up	Up	Down	Down	Up	Up

For example, if DIP switch positions 3 and 5 are in the 1 (up) position and the rest are 0 (down), the resulting Modbus address is 4 + 16 = 20.

Once you are communicating with the meter, you can change the address using either the DIP switches or the Address(1652) register.

Setting all DIP switch positions to zero for ten seconds resets all communication settings to the factory configuration.

### Setting the baud rate

Select the baud rate by setting DIP switch position 8 as shown below. The change will take effect immediately. You may also use the BaudRate(1653) register to reprogram the baud rate from 1,200 to 115,200 baud.

Baud rate	DIP switch position 8
9,600 (default)	0 (down)
19,200	1 (up)

## 7.1.1 Wiring

### Connecting Modbus outputs

The meter communicates using a serial RS485 interface. The meter uses half-duplex two-wire (plus common) communication, so the same pair of wires is used for sending AND receiving. Up to 63 devices can be connected together on the same RS485 bus (or up to 247 devices if you assign Modbus addresses using the Address register).

### Planning the Modbus network

RS485 networks should always be wired in a bus (or daisy-chain) configuration. In other words, the bus should start at the PC, Modbus master, or monitoring device and then run to each meter in turn. Try to avoid branches, and avoid home-run wiring (where each meter has its own wire back to the PC or logger).

- Since the Modbus / RS485 wiring may be located near line voltage wiring, use wires or cables rated for the highest voltage present, generally 300 V or 600 V rated wire.
- If this cable will be in the presence of bare conductors, such as bus-bars, it should be double insulated or jacketed.
- Use shielded twisted-pair cable to prevent interference.

Because the meter uses half-duplex communication, it only needs a single twisted-pair, but it also needs a conductor for common, which may be the shield or a spare conductor.

### Length limits

Under ideal conditions, using cable with a 120 ohm impedance and proper termination, it should be possible to run RS485 signals 1200 m (4000 ft) at up to 19,200 baud. However, a number of factors can reduce this range, including electrical and magnetic interference (EMI), bus loading, poor termination, etc. Repeaters are available to extend the range if necessary.

If it isn't convenient to daisy-chain the main RS485 bus to each meter, you may use stubs or branches.

Long stubs or branches, greater than 30 m (100 ft), may cause signal reflections and should be avoided.

### Termination

Networks shorter than 500 m (1650 ft) should not need termination. Longer networks and networks in electrically noisy environments may need termination at both ends of the bus with 120 ohm resistors between the "A-" and "B+" terminals. Generally, you will put one termination resistor at the PC or monitoring device and one at the meter farthest from the monitoring device.

Some RS485 PC interfaces include jumpers or switches to provide internal termination at one end of the bus.

In some cases, termination can cause problems. It dramatically increases the load on the bus, so that some RS485 PC interfaces cannot handle the load (particularly port powered ones). Also, adding 120 ohm termination resistors may require the addition of bias resistors (see next section).

### Biasing

RS485 networks frequently use bias resistors to hold the bus in a "high" or logic 1 state when no devices are transmitting. In this state, the Modbus "A-" terminal is more negative than the "B+" terminal. Without bias resistors, the bus can float and noise can appear as bogus data.

The meter uses an RS485 failsafe transceiver that eliminates the need for bias resistors except in noisy environments. Furthermore, many RS485 PC interfaces include internal bias resistors, so it is rare to need to add bias resistors.

If you determine that your network is experiencing noise problems, then you may want to add termination and possibly bias resistors.

### **Wiring**

Once you've planned the network and strung the cable, you can connect the meters.

- The Modbus terminals (A-, B+, C, and X) are completely isolated (4500 Vac RMS isolation) from dangerous voltages, so you can connect them with the meter powered. They are also isolated from the meter's earth ground and neutral connections.
- When connecting meters to a PC or monitoring device, connect all "A-" terminals together, all "B+" terminals together, and all "C" (common) terminals together. In most cases, if you swap "A-" and "B+", Modbus meters can auto-detect the polarity and communicate correctly. Note: if your RS485 network isn't properly biased (one terminal more positive than the other), then the auto-detect feature will not work.
- You may put two sets of wires in each screw terminal to make it easier to daisy-chain the network from one device to the next. If you do this, we recommend that you twist the wires tightly together before putting them into the screw terminal to ensure that one wire doesn't pull free, causing communication problems.
- If you are using shielded cable, you may use the shield to provide the Modbus common "C" connection between all devices on the network.
- Connect the cable shield or Modbus common (if there is no shield) to earth ground at just the Modbus master end of the cable. Grounding both ends can cause ground loops. Leaving the common floating risks damaging the RS485 circuitry.

### 7.1.2 Communication diagnostics

The “Com” LED indicates many Modbus communication conditions by lighting green, yellow, or red. Other Modbus errors are indicated by returning a Modbus exception response to the master and by saving an error code to the ErrorStatus(1712-1723) registers.

#### Modbus idle

Whenever the Modbus network is idle, the Com LED will stay off.

#### Received packet / sending response

Every time the meter receives a properly formatted packet it will light the LED green for 200 milliseconds.

Green	Off
0.2 sec	

#### Other Modbus activity

If the meter sees packets on the bus addressed to other devices, it will light the LED yellow for 200 milliseconds or longer if the packet duration is longer than 200 milliseconds.

Yellow	Off
0.2 sec	

#### Modbus address zero invalid

Modbus address 0 is reserved for broadcast messages, so if the DIP switch is set for address zero, the Com LED will light red continuously and the meter will not respond to any Modbus packets.



### Invalid Modbus packet

The meter will light the Com LED red for one second for any of the following errors (the ErrorStatus(1712-1723) registers will also be set, but depending on the problem you may not be able to read register values).

- CRC error: this could indicate noise on the RS485 bus.
- Framing error: this normally indicates a bad baud rate or noise on the RS485 bus. This can happen if you have the “A-” and “B+” wires swapped and your network isn’t properly biased. Properly biased networks will transparently auto-detect that “A-” and “B+” wires are swapped and correct. Note: some RS485 PC interfaces label “A” and “B” the opposite of the meter or just use “+” and “-” indications.
- Buffer overrun error: the packet was longer than 256 bytes.
- Parsing error: the packet could not be correctly parsed as a Modbus packet.

Red	Off
1.0 sec	

### Invalid request

If the meter receives a valid packet, but with an invalid request (see below), then the meter will respond with a Modbus exception message and store an error in the ErrorStatus(1712-1723) registers. Because the packet was valid, Com LED will flash green for 200 milliseconds.

Green	Off
0.2 sec	

### Modbus exceptions

If the meter receives an invalid request, it will reply with a Modbus exception code. In most cases, your PC software should be able to display the code, which should help you determine the problem. For more information about the problem, check the [ErrorStatus](#)(1712-1723) registers, which will provide more detailed error codes.

- 01 - Illegal function code
  - ErrorStatus 213: The Modbus function code is not supported by the meter, such as 07 Read Exception Status.
- 02 - Illegal data address
  - ErrorStatus 206: Attempted to read an invalid register address or write to a read-only register. This is common if your addresses are off by one or you request extra registers.
  - ErrorStatus 203: A partial 32 bit write (a dual register like ConfigPasscode) was aborted by a write to an unrelated register.
- 03 - Illegal data value
  - ErrorStatus 202: When changing the ConfigPasscode, the confirmation entry didn’t match the first entry.
  - ErrorStatus 205: Invalid ConfigPasscode value entered. You will have to wait five seconds to try again.
  - ErrorStatus 207, 208: An attempt was made to write an illegal data value to a register.
  - ErrorStatus 211, 212: The Modbus packet contained an invalid count of registers or an invalid byte count.
- 04 - Slave device failure
  - ErrorStatus 200: The correct ConfigPasscode must be entered before changing configuration registers, or resetting the energy or demand registers.
  - ErrorStatus 19, 20, 72, 79, 80, 215: Internal hardware failure.
  - ErrorStatus 67: Calibration data lost. The meter will report a slave device failure until it is calibrated.
- 06 - Slave device busy
  - ErrorStatus 209: Attempts to unlock the configuration with ConfigPasscode are locked out for five seconds after entering an invalid passcode.

### Diagnostic registers

If Modbus communications are working, but with intermittent problems, check the following diagnostic registers (see [Diagnostic Registers](#) for details): ErrorStatus(1712-1723), CrcErrorCount(1712), FrameErrorCount(1713), PacketErrorCount(1714), OverrunCount(1715).

### 7.1.3 Registers

The Modbus registers are grouped as follows, with detailed information in the following sections.

- Measurement Registers: Floating-point
- Measurement Registers: Integer
- Configuration Registers: Integer
- Customer Diagnostic Registers: Integer
- Option Information Registers: Integer
- Custom Register Map

#### Modbus register addressing

There are a few points about Modbus register addressing that can cause confusion.

- In the Modbus specification, register numbers are documented as “one based”, but transmitted as “zero based”. For example, we document that EnergySum appears at address 1001. If you are using any Modbus software or Modbus aware device, you should use “1001” as the register address. However, if you are writing your own low-level Modbus driver or firmware, you will need to subtract one from the register number when creating the Modbus frame (or packet), so the actual register number that appears on the RS485 bus will be “1000” (or in hexadecimal, 0x03E8).
- A common Modbus convention adds the function code as a leading digit on the register number, so a register like EnergySum(1001) would be documented as 41001. All input registers (function code 04) would use the form 4xxx, while holding registers (function code 03) would use the form 3xxx. The meter treats holding registers and input registers interchangeably, and does not use this convention. If your Modbus software expects a leading “3” or “4”, either will work for most registers, and use “3” for configuration registers.

#### Floating point and integer registers

Most registers are available in floating point and integer formats. We generally recommend using the floating point registers, because they provide more resolution and dynamic range and they never requiring scaling. However, for energy variables, the 32 bit integer registers may be a better choice, because they provide a constant resolution of 0.1 kWh. Since most of the integer registers are 16 bits, they are faster to transfer over the Modbus interface and may require less space if they are being logged.

Most of the integer registers are 16 bit signed integers that can report positive or negative values from -32,768 to +32,767. In a few special cases, such as the energy registers, we use 32 bit signed integer registers (sometimes called “long integer”), which use two adjacent Modbus registers and can report values up to approximately  $\pm$  two billion.

Floating point values can report positive or negative values with typically six or seven significant digits, which is far higher than the meter’s accuracy. However, for energy measurements (kWh), floating point values have a limitation: the effective resolution in kWh gets lower as more energy accumulates. If the total energy exceeds 100,000 kWh, the resolution of the floating point energy will become coarser than 0.1 kWh, the constant resolution of the integer energy values. At a total energy of 1,000,000 kWh, the floating point energy resolution becomes 1.0 kWh.

#### Reading and writing 32 bit registers

Since floating point and 32 bit long integer registers require two adjacent registers to store 32 bits, there are some things to note when reading and writing these 32 bit dual registers:

- The first register (at the lower address) contains the least significant 16 bits of data. This is called little-endian and is the default for many programs that read 32 bit Modbus values, but if this results in bizarre values (very large, very small, strange exponents, invalid values), look for an option to reverse the registers, commonly referred to as “Float - Swapped”, “Float - Reversed”, “Long - Swapped”, etc. Do not select 64 bit double precision formats.
- When reading a 32 bit register, read both registers with a single Modbus read command. The meter is guaranteed to return consistent results for a single multiple register read command. If you (or your software) issues two separate read commands for the two registers making up a 32 bit register, the underlying 32 bit register may be updated between the two read commands, resulting in an inconsistent or scrambled value.
- When writing to 32 bit registers, the recommended approach is to use the Write Multiple Registers (16) command to update both registers at the same time. However, meter incorporates logic to allow two Write Single Register (06) commands within 30 seconds, provided no other Modbus commands are issued between the two writes.

### 7.1.3.1 Basic registers

#### Basic register list - floating point

The following registers provide the most commonly used measurements in floating point units. See basic registers below for detailed information.

Registers	Name	Units	Description
<b>Energy registers</b>			
1001 - 1002	EnergySum *†	kWh	Total net (bidirectional) energy
1003 - 1004	EnergyPosSum *†	kWh	Total positive energy
1005 - 1006	EnergySumNR *	kWh	Total net (bidirectional) energy - non-resettable
1007 - 1008	EnergyPosSumNR *	kWh	Total positive energy - non-resettable
<b>Power registers</b>			
1009 - 1010	PowerSum	W	Real power, sum of active phases
1011 - 1012	PowerA	W	Real power, phase A
1013 - 1014	PowerB	W	Real power, phase B
1015 - 1016	PowerC	W	Real power, phase C
<b>Voltage registers</b>			
1017 - 1018	VoltAvgLN	V	Average line to neutral voltage
1019 - 1020	VoltA	V	RMS voltage, phase A to neutral
1021 - 1022	VoltB	V	RMS voltage, phase B to neutral
1023 - 1024	VoltC	V	RMS voltage, phase C to neutral
1025 - 1026	VoltAvgLL	V	Average line to line voltage
1027 - 1028	VoltAB	V	RMS voltage, line to line, phase A to B
1029 - 1030	VoltBC	V	RMS voltage, line to line, phase B to C
1031 - 1032	VoltAC	V	RMS voltage, line to line, phase A to C
<b>Frequency register</b>			
1033 - 1034	Freq	Hz	Power line frequency

\*These registers are preserved across power failures.

†These registers support resetting or presetting the value.

#### Basic register list - integers

The following registers provide the most commonly used measurements in integer units. The energy registers are 32 bit signed integer values, which require two registers, the first register provides the lower 16 bits, and the second register provides the upper 16 bits of the 32 bit value. See basic registers below for detailed information.

Registers	Name	Units	Description
<b>Energy registers</b>			
1201 - 1202	EnergySym *†	0.1 kWh	Total net (bidirectional) energy
1203 - 1204	EnergyPosSum *†	0.1 kWh	Total positive energy
1205 - 1206	EnergySumNR *	0.1 kWh	Total net (bidirectional) energy non resettable
1207 - 1208	EnergyPosSumNR *	0.1 kWh	Total positive energy non resettable
<b>Power registers</b>			
1209	PowerSum	PowerIntScale	Real power, sum of active phases
1210	PowerA	PowerIntScale	Real power, phase A

1211	PowerB	PowerIntScale	Real power, phase B
1212	PowerC	PowerIntScale	Real power, phase C
<b>Voltage registers</b>			
1213	VoltAvgLN	0.1 V	Average line to neutral voltage
1214	VoltA	0.1 V	RMS voltage, phase A to neutral
1215	VoltB	0.1 V	RMS voltage, phase B to neutral
1216	VoltC	0.1 V	RMS voltage, phase C to neutral
1217	VoltAvgLL	0.1 V	Average line to line voltage
1218	VoltAB	0.1 V	RMS voltage, line to line, phase A to B
1219	VoltBC	0.1 V	RMS voltage, line to line, phase B to C
1220	VoltAC	0.1 V	RMS voltage, line to line, phase A to C
<b>Frequency register</b>			
1221	Freq	0,1 Hz	Power line frequency

\*These registers are preserved across power failures.

†These registers support resetting or presetting the value.

### Energy registers

Commonly known as kWh (kilowatt-hours), the energy is the integral of power over time. Many installations will only use the energy measurement. It is commonly used for billing or sub-metering. Because energy is an accumulated value, it can be used on networks that are accessed infrequently (like a utility meter that only needs to be read once a month). All energy register values are preserved through power failures.

In the meter, most energy registers can be reset to zero by writing "1" to the ZeroEnergy register. They can also be set to zero or a preset value by writing the desired value directly to each register. All energy registers ending with "NR" (for non-resetting) cannot be reset to zero for billing security. You can protect all energy registers from being zeroed or preset by setting a ConfigPasscode.

All energy registers wrap around to zero when they reach 100 gigawatt-hours ( $100 \times 10^9$  watt-hours) or negative 100 gigawatt-hours (only some energy registers allow negative values).

During a power outage, the energy consumed will not be measured. Whenever the line voltage drops below 60–80% of nominal, the meter will shut down until power is restored. To preserve the energy measurement across power outages, the meter writes the energy to non-volatile (ferroelectric RAM) memory every second. When power returns, the last stored value is recovered.

### EnergySum, EnergySumNR

EnergySum is the net real energy sum of all active phases, where "net" means negative energy will subtract from the total. This value is appropriate for net metering applications (i.e. photovoltaic) where you wish to measure the net energy in situations where you may sometimes consume energy and other times generate energy. Use EnergyPosSum instead if you don't want negative energy to subtract from the total.

EnergySum is reset to zero when "1" is written to the ZeroEnergy register.

The EnergySumNR is identical to EnergySum except that it cannot be reset to zero.

EnergyPosSum, EnergyPosSumNR

EnergyPosSum is equivalent to a traditional utility meter that can only spin in one direction. Every second, the measured real energies for each active phase are added together. If the result is positive, it is added to EnergyPosSum. If it is negative, then EnergyPosSum is left unchanged.

EnergyPosSum is reset to zero when "1" is written to the ZeroEnergy register.

The EnergySumPosNR is identical to EnergySumPos except that it cannot be reset to zero.

**Power registers**PowerA, PowerB, PowerC

The meter measures real power (watts) for each phase (PowerA, PowerB, PowerC). The measured power is generally positive, but may also be negative, either because you are generating power (such as with solar panels), or because the meter isn't connected properly.

The integer power registers are scaled by PowerIntScale to prevent overflow. The integer power registers can only report values from -32767 to +32767. To allow for large power values, PowerIntScale acts as a multiplier to multiply by 1, 10, 100, or 1000. See [Configuration Registers](#) for details. To scale the integer PowerA, PowerB, PowerC, or PowerSum to watts, use the following equation:

$$\text{Power(W)} = \text{PowerSum} * \text{PowerIntScale}$$

For example, if PowerIntScale (1609) is 100, and the integer PowerSum (1209) reports 2500, then the power sum is  $2500 * 100 = 250,000 \text{ W}$  (or 250 kW).

PowerSum

This is the sum of the real power for active phases (line voltage above 20% of nominal). This can include negative values, so if one phase is negative, it will reduce the reported PowerSum.

**Voltage registers**

All integer voltage registers are reported in units of 0.1 VAC, so 1234 = 123.4 VAC.

VoltAvgLN

This is the average line-to-neutral voltage (average of VoltA, VoltB, and VoltC). Only active phases are included (phases where the voltage is above 20% of nominal).

VoltA, VoltB, VoltC

These are the RMS AC voltages for each phase, measured relative to the neutral connection on the meter. If neutral is not connected, then they are measured relative to the ground connection. Voltage phases that are not connected may report small random voltages, but the meter treats any phase reporting less than 20% of the nominal VAC as inactive and will not measure power or energy on inactive phases.

VoltAvgLL

This is the average line-to-line voltage (average of VoltAB, VoltBC, and VoltAC). All phases are included in the average.

VoltAB, VoltBC, VoltAC

The meter cannot directly measure line-to-line voltages. It provides these registers as estimates of the line-to-line voltage. In order to estimate these voltages, the meter must know the phase offset or the type of electrical service (see PhaseOffset configuration register).

**Frequency**Freq

The meter measures the AC line frequency in Hertz. The integer Freq register reports the frequency in units of 0.1 Hz. All phases must have the same line frequency; otherwise this value will be erratic or incorrect.

### 7.1.3.2 Advanced register

#### Advanced register list - floating point

The following registers provide more advanced measurements in floating point units. See advanced registers below for detailed information.

Registers	Name	Units	Description
<b>Energy registers</b>			
1101 - 1102	EnergyA *†	kWh	Net (bidirectional) energy, phase A
1103 - 1104	EnergyB *†	kWh	Net (bidirectional) energy, phase B
1105 - 1106	EnergyC *†	kWh	Net (bidirectional) energy, phase C
1107 - 1108	EnergyPosA *†	kWh	Positive energy, phase A
1109 - 1110	EnergyPosB *†	kWh	Positive energy, phase B
1111 - 1112	EnergyPosC *†	kWh	Positive energy, phase C
1113 - 1114	EnergyNegSum *†	kWh	Negative energy, sum of active phases
1115 - 1116	EnergyNegSumNR *	kWh	Negative energy, sum of active phases non resettable
1117 - 1118	EnergyNegA *†	kWh	Negative energy, phase A
1119 - 1120	EnergyNegB *†	kWh	Negative energy, phase B
1121 - 1122	EnergyNegC *†	kWh	Negative energy, phase C
1123 - 1124	EnergyReacSum *†	kVARh	Reactive energy, sum of active phases
1125 - 1126	EnergyReacA *†	kVARh	Net reactive energy, phase A
1127 - 1128	EnergyReacB *†	kVARh	Net reactive energy, phase B
1129 - 1130	EnergyReacC *†	kVARh	Net reactive energy, phase C
1131 - 1132	EnergyAppSum *†	kVAh	Apparent energy, sum of active phases
1133 - 1134	EnergyAppA *†	kVAh	Apparent energy, phase A
1135 - 1136	EnergyAppB *†	kVAh	Apparent energy, phase B
1137 - 1138	EnergyAppC *†	kVAh	Apparent energy, phase A
<b>Power factor registers</b>			
1139 - 1140	PowerFactorAvg		Power factor, average
1141 - 1142	PowerFactorA		Power factor, phase A
1143 - 1144	PowerFactorB		Power factor, phase B
1145 - 1146	PowerFactorC		Power factor, phase C
<b>Reactive and apparent power registers</b>			
1147 - 1148	PowerReacSum	VAR	Reactive power, sum of active phases
1149 - 1150	PowerReacA	VAR	Reactive power, phase A
1151 - 1152	PowerReacB	VAR	Reactive power, phase B
1153 - 1154	PowerReacC	VAR	Reactive power, phase C
1155 - 1156	PowerAppSum	VA	Apparent power, sum of active phases
1157 - 1158	PowerAppA	VA	Apparent power, phase A
1159 - 1160	PowerAppB	VA	Apparent power, phase B
1161 - 1162	PowerAppC	VA	Apparent power, phase C
<b>Current registers</b>			
1163 - 1164	CurrentA	A	RMS current, phase A
1165 - 1166	CurrentB	A	RMS current, phase B

1167 - 1168	CurrentC	A	RMS current, phase C
<b>Demand registers</b>			
1169 - 1170	Demand	W	Real power demand averaged over the demand period
1171 - 1172	DemandMin *	W	Minimum power demand
1173 - 1174	DemandMax *	W	Maximum power demand
1175 - 1176	DemandApp	W	Apparent power demand
1177 - 1178	DemandA	W	Real power demand, phase A
1179 - 1180	DemandB	W	Real power demand, phase B
1181 - 1182	DemandC	W	Real power demand, phase C

\*These registers are preserved across power failures.

†These registers support resetting or presetting the value.

#### Advanced register list - integer

These registers provide advanced integer measurements. The energy registers are 32 bit signed dual registers: the first register provides the lower 16 bits, and the second register provides the upper 16 bits of the 32 bit value. See advanced registers below for detailed information.

Registers	Name	Units	Description
<b>Energy registers</b>			
1301 - 1302	EnergyA *†	0.1 kWh	Net energy, phase A
1303 - 1304	EnergyB *†	0.1 kWh	Net energy, phase B
1305 - 1306	EnergyC *†	0.1 kWh	Net energy, phase C
1307 - 1308	EnergyPosA *†	0.1 kWh	Positive energy, phase A
1309 - 1310	EnergyPosB *†	0.1 kWh	Positive energy, phase B
1311 - 1312	EnergyPosC *†	0.1 kWh	Positive energy, phase C
1313 - 1314	EnergyNegSum *†	0.1 kWh	Negative energy, sum of active phases
1315 - 1316	EnergyNegSumNR *	0.1 kWh	Negative energy, sum of active phases non resettable
1317 - 1318	EnergyNegA *†	0.1 kWh	Negative energy, phase A
1319 - 1320	EnergyNegB *†	0.1 kWh	Negative energy, phase B
1321 - 1322	EnergyNegC *†	0.1 kWh	Negative energy, phase C
1323 - 1324	EnergyReacSum *†	0.1 kVARh	Reactive energy, sum of active phases
1325 - 1326	EnergyReacA *†	0.1 kVARh	Net reactive energy, phase A
1327 - 1328	EnergyReacB *†	0.1 kVARh	Net reactive energy, phase B
1329 - 1330	EnergyReacC *†	0.1 kVARh	Net reactive energy, phase C
1331 - 1332	EnergyAppSum *†	0.1 kVAh	Apparent energy, sum of active phases
1333 - 1334	EnergyAppA *†	0.1 kVAh	Apparent energy, phase A
1335 - 1336	EnergyAppB *†	0.1 kVAh	Apparent energy, phase B
1337 - 1338	EnergyAppC *†	0.1 kVAh	Apparent energy, phase C
<b>Power factor registers</b>			
1339	PowerFactorAvg	0.01	Power factor, average
1340	PowerFactorA	0.01	Power factor, phase A
1341	PowerFactorB	0.01	Power factor, phase B
1342	PowerFactorC	0.01	Power factor, phase C
<b>Reactive and apparent power registers</b>			

1343	PowerReacSum	PowerIntScale	Reactive power, sum of active phases
1344	PowerReacA	PowerIntScale	Reactive power, phase A
1345	PowerReacB	PowerIntScale	Reactive power, phase B
1346	PowerReacC	PowerIntScale	Reactive power, phase C
1347	PowerAppSum	PowerIntScale	Apparent power, sum of active phases
1348	PowerAppA	PowerIntScale	Apparent power, phase A
1349	PowerAppB	PowerIntScale	Apparent power, phase B
1350	PowerAppC	PowerIntScale	Apparent power, phase C
<b>Current registers</b>			
1351	CurrentA	CurrentIntScale	RMS current, phase A
1352	CurrentB	CurrentIntScale	RMS current, phase B
1353	CurrentC	CurrentIntScale	RMS current, phase C
<b>Demand registers</b>			
1354	Demand	PowerIntScale	Real power demand averaged over the demand period
1355	DemandMin *	PowerIntScale	Minimum power demand
1356	DemandMax *	PowerIntScale	Maximum power demand
1357	DemandApp	PowerIntScale	Apparent power demand
1358	DemandA	PowerIntScale	Real power demand, phase A
1359	DemandB	PowerIntScale	Real power demand, phase B
1360	DemandC	PowerIntScale	Real power demand, phase C

\*These registers are preserved across power failures.

†These registers support resetting or presetting the value.

### Per-Phase energy registers

#### EnergyA, EnergyB, EnergyC

The per-phase energy registers report the net real energy for each phase, where “net” means negative energy will subtract from the total. This value is appropriate for net metering applications (i.e. photovoltaic) where you wish to measure the net energy in situations where you may sometimes consume energy and other times generate energy.

These values are reset to zero when “1” is written to the ZeroEnergy register. You may also reset them to zero or load preset values by writing to these registers.

### Positive energy

#### EnergyPosA, EnergyPosB, EnergyPosC

The per-phase positive energy registers measure the positive real energy for each phase. Negative energy is ignored (instead of subtracting from the total). Energy is measured once per second, so the determination of whether the energy is positive is based on the overall energy for the second.

These values are reset to zero when “1” is written to the ZeroEnergy register. You may also reset them to zero or load preset values by writing to these registers.

### Negative energy

The negative energy registers are exactly like the positive energy registers except they accumulate negative energy. The reported energy values will be positive. In other words, if meter measures 1000 kWh of negative energy, EnergyNegSum will report 1000 (not -1000).

The negative energy registers are reset to zero (except for EnergySumNegNR) when “1” is written to the ZeroEnergy register. You may also reset them to zero or load preset values (except for EnergySumNegNR) by writing to these registers.

EnergyNegSum

Every second, the measured real energies for each active phase are added together. If the result is negative, it is added to EnergyNegSum. If it is positive, then EnergyNegSum is left unchanged.

EnergyNegSumNR

The EnergySumNegNR is identical to EnergyNegPos except that it cannot be reset to zero.

EnergyNegA, EnergyNegB, EnergyNegC

These are the per-phase negative real energy registers.

**Reactive energy**EnergyReacSum, EnergyReacA, EnergyReacB, EnergyReacC

Reactive energy is also known as kVAR-hours. Inductive loads, like motors, generate positive reactive power and energy, while capacitive loads generate negative reactive energy. These are all bidirectional registers that can count up or down depending on the sign of the reactive power.

The meter only measures the fundamental reactive energy, not including harmonics.

These values are reset to zero when "1" is written to the ZeroEnergy register. You may also reset them to zero or load preset values by writing to these registers.

**Apparent energy**EnergyAppSum, EnergyAppA, EnergyAppB, EnergyAppC

Apparent energy (kVA-hours) is the accumulation of apparent power over time. The apparent power is essentially the RMS voltage multiplied by the RMS current for each phase. For example, if you have 120 VAC RMS, 10 amps RMS, one phase, the apparent power will be 1200 VA. At the end of an hour, the apparent energy will be 1.2 kVA-hour. Apparent energy is always positive.

The meter's apparent energy includes real harmonics, but not reactive harmonics.

These values are reset to zero when "1" is written to the ZeroEnergy register. You may also reset them to zero or load preset values by writing to these registers.

**Power factor**

The power factor is the ratio of the real power to the apparent power. Resistive loads, like incandescent lighting and electric heaters, should have a power factor near 1.0. Power-factor corrected loads, like computers, should be near 1.0. Motors can have power factors from 0.2 to 0.9, but are commonly in the 0.5 to 0.7 range.

If the power for a phase is negative, the power factor will also be negative. The reported power factor will be 1.0 for any phases measuring zero power, and will be 0.0 for any inactive phases (line voltage below 20% of nominal VAC).

The meter measures the displacement or fundamental power factor, which does not include harmonics. Integer power factor registers are reported in units of 0.01, so 85 equals a power factor of 0.85.

PowerFactorA, PowerFactorB, PowerFactorC

These are the power factor values for each phase.

PowerFactorAvg

This is the average power factor, computed as PowerSum / ApparentPowerSum.

**Reactive power**

Reactive power is also known as VARs. Inductive loads, like motors, generate positive reactive power, while capacitive loads generate negative reactive power. Reactive power transfers no net energy to the load and generally is not metered by the utility. Loads with high reactive power relative to the real power will tend to have lower power factors. The integer reactive power registers are scaled by PowerIntScale.

The meter only measures the fundamental reactive power, not including harmonics.

To scale the integer PowerReacA, PowerReacB, PowerReacC, or PowerReacSum to VARs, use the following equation:

$$\text{PowerReac(VAR)} = \text{PowerReacSum} * \text{PowerIntScale}$$

For example, if PowerIntScale (1609) is 100, and the integer PowerReacSum (1343) reports 1500, then the reactive power sum is  $1500 * 100 = 150,000$  VAR (or 150 kVAR).

#### PowerReacA, PowerReacB, PowerReacC

These are the per-phase reactive power measurements.

#### PowerReacSum

The PowerReacSum is the sum of the reactive power of active phases. This can include negative values, so if one phase is negative, it will reduce the reported PowerReacSum.

#### **Apparent power**

Apparent power (VA) can be described three ways:

- The RMS voltage multiplied by the RMS current.
- The square root of the real power squared plus the reactive power squared.
- The absolute value or magnitude of the complex power.

The meter's measurement of apparent power includes real, but not reactive harmonic apparent power content.

Apparent power is always a positive quantity. The integer apparent power registers are scaled by PowerIntScale.

#### PowerAppA, PowerAppB, PowerAppC

These are the per-phase apparent power measurements.

#### PowerAppSum

The PowerAppSum is the sum of apparent power for active phases.

#### **Current**

The meter estimates the RMS current for each phase. This is an indirect measurement and does not include all harmonic content, so the current is not as accurate as the power and energy measurements.

#### CurrentA, CurrentB, CurrentC

Technically, AC current does not have a sign (positive or negative), but the meter sets the sign of the current to match the sign of the real power for the same phase. For example, if the power on phase A is negative, then the current for phase A (CurrentA) will also be negative.

The floating point current registers are in units of amps. The integer current registers are in scaled amps (CurrentIntScale, default value 20000), so the following equations will convert to amps.

$$\begin{aligned} I_a &= \text{CurrentAInt} * \text{CtAmpsA} / \text{CurrentIntScale} \\ I_b &= \text{CurrentBInt} * \text{CtAmpsB} / \text{CurrentIntScale} \\ I_c &= \text{CurrentCInt} * \text{CtAmpsC} / \text{CurrentIntScale} \end{aligned}$$

For example, with 200 amp current transformers and CurrentIntScale = 20000, if CurrentAInt (1351) reports 5000, the actual current is  $5000 * 200 / 20000 = 50.00$  amps.

#### **Demand**

Demand is defined as the average power over a specified time interval. Typical demand intervals are 5, 10, 15 (default), 30, 60, etc. up to 720 minutes, but the meter supports arbitrary demand intervals from 1 to 720 minutes (12 hours). The meter records the peak demand for metering applications where the measurements may only be accessed weekly or monthly.

Since the meter can measure bidirectional power (positive and negative), and the demand is the average power over an interval, demand can also be positive or negative. This is only likely to occur with something like a grid-tied PV system, where you may put energy back into the grid at certain times of the day (negative power). In this case, you would see negative demand. If you have both positive and negative power during a

demand interval, both the positive and the negative data will be averaged together, such that the negative power subtracts from the positive, reducing the overall demand.

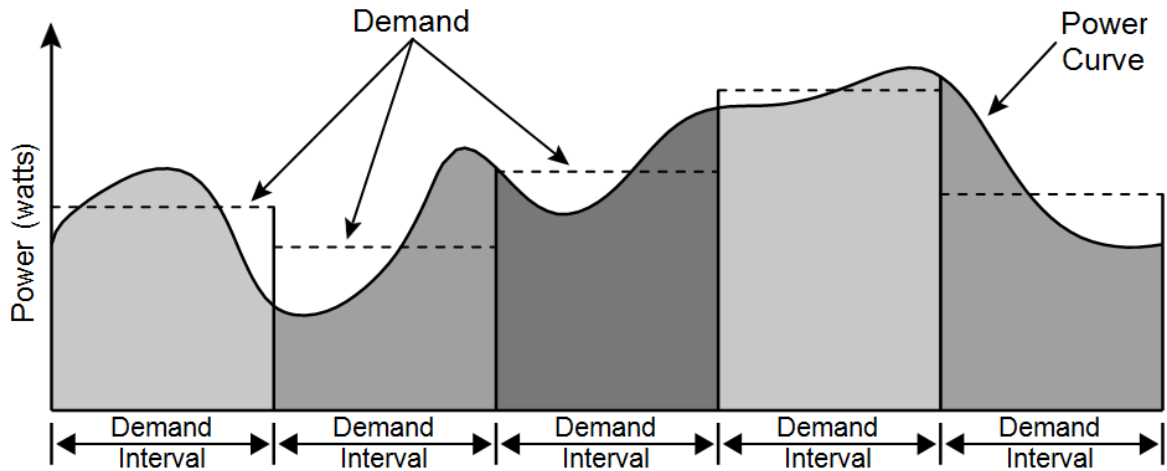

The meter also supports rolling demand (also called “sliding window”), in which the demand intervals are evenly divided into a fixed number of subintervals. At the end of each subinterval, the average power over the demand interval is computed and output. This results in better accuracy, especially for demand peaks which would not have lined up with the demand interval without subintervals. On power up, the demand measurements will report zero until one full demand interval is completed. From 1 to 10 subintervals are supported. A subinterval count of one (or zero) results in the standard demand measurement without rolling demand. See [Configuration Registers](#) for information on configuring the demand.

Any changes to the demand configuration ([DemPerMins](#), [DemSubints](#)) or CT configuration (CtAmps, CtAmpsA, CtAmpsB, CtAmpsC, CtDirections) will zero the reported demand and start a new demand measurement. The DemandMin and DemandMax will not be reset by configuration changes.

To manually zero some or all of the demand registers, see the ZeroDemand register in [Configuration Registers](#).

The floating point demand registers are reported in units of watts, while the integer demand registers must be scaled by PowerIntScale to compute watts. To scale the integer Demand, DemandA, DemandB, DemandC, DemandMin, DemandMax, or DemandApp, use the following equation:

$$\text{ScaleDemand}(W) = \text{Demand} * \text{PowerIntScale}$$

For example, if PowerIntScale (1609) is 100, and the integer ScaleDemand (1354) reports 4700, then the demand is  $4700 * 100 = 470,000$  watts (or 470 kW).

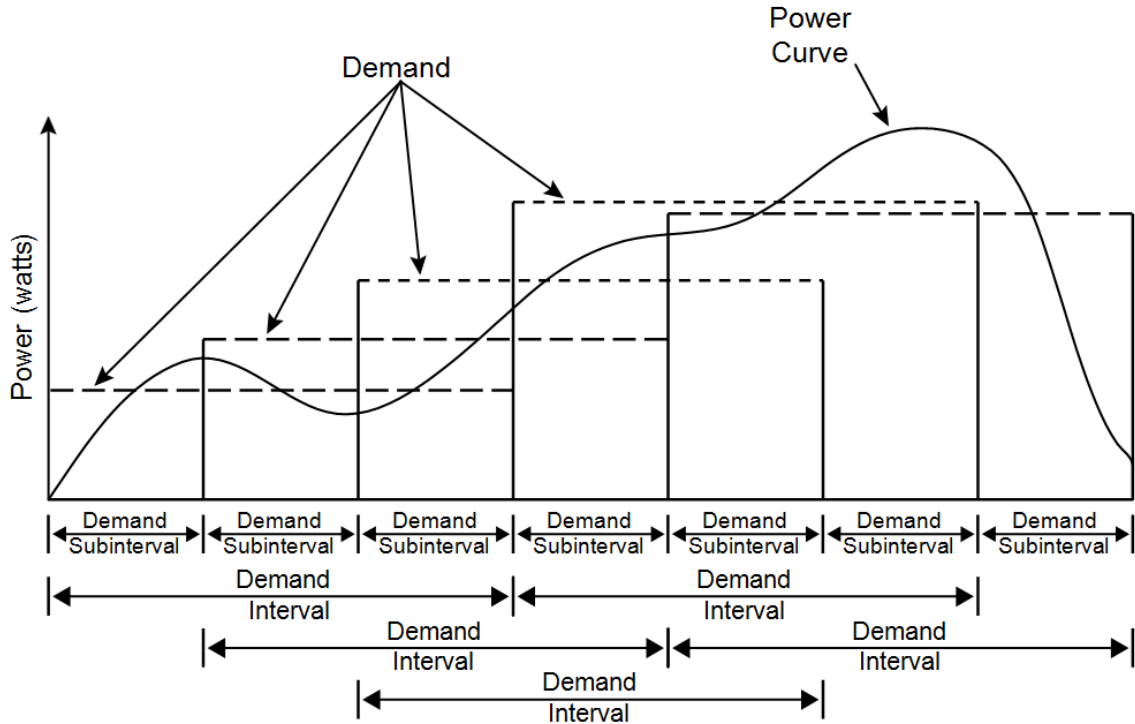

**DemandSum**

The DemandSum register is updated at the end of every subinterval with the average PowerSum over a full demand interval. After a power cycle or configuration change, DemandSum will report zero until the completion of one full demand interval.

**DemandA, DemandB, DemandC**

The real power demand is computed for each phase from PowerA, PowerB, and PowerC.

**DemandSumMin**

The DemandSumMin is the smallest measured Demand (this may be negative for systems with power generation). It is preserved across power failures and can be reset with the ZeroDemand register. Note: there are no minimum or maximum demand registers for DemandA, DemandB, and DemandC.

**DemandSumMax**

The DemandSumMax is the largest measured Demand. It is preserved across power failures and can be reset with the ZeroDemand register.

**DemandAppSum**

DemandAppSum is computed the same way as Demand, but using apparent power.

**7.1.3.3 Configuration register list**

**Configuration register list**

These integer registers configure and customize the Modbus meter. For simple installations, only CtAmps needs to be set. By default, there is no passcode for the configuration, but if security is required, a passcode can be assigned. The configuration registers are all integer format. See the section configuration registers below for detailed information.

Registers	Name	Units	Default	Description
1601 - 1602	ConfigPasscode		0	Optional passcode to prevent unauthorized changes to configuration
1603	CtAmps	1 A	5	Assign global current transformer rated current
1604	CtAmpsA *	1 A	5	ØA CT rated current (0 to 6000)
1605	CtAmpsB *	1 A	5	ØB CT rated current (0 to 6000)

1606	CtAmpsC *	1 A	5	ØC CT rated current (0 to 6000)
1607	CtDirections *		0	Optionally invert CT orientations (0 to 7)
1608	Averaging *		1 (fast)	Configure measurement averaging (0 to 3)
1609	PowerIntScale *	1 W	0 (auto)	Scaling for integer power register (0 to 1000)
1610	DemPerMins *	1 minute	15	Demand period (1 to 720)
1611	DemSubints *		1	Number of demand subintervals (1 to 10)
1612	GainAdjustA *	1/10000th	10000	ØA power/energy adjustment (5000 to 20000)
1613	GainAdjustB *	1/10000th	10000	ØB power/energy adjustment (5000 to 20000)
1614	GainAdjustC *	1/10000th	10000	ØC power/energy adjustment (5000 to 20000)
1615	PhaseAdjustA *	0.001 deg	-1000	ØA CT phase angle adjust (-8000 to 8000)
1616	PhaseAdjustB *	0.001 deg	-1000	ØB CT phase angle adjust (-8000 to 8000)
1617	PhaseAdjustC *	0.001 deg	-1000	ØC CT phase angle adjust (-8000 to 8000)
1618	CreepLimit *		1500	Minimum power for readings (100 to 10000)
1619	PhaseOffset *	1 degree	120	Not used. Will return a value of 0 if read.
1620	ZeroEnergy		0	Write 1 to zero all resettable energy registers
1621	ZeroDemand		0	Write 1 to zero all demand values
1622	CurentIntScale *		20000	Scale factor for integer currents (0 to 32767)
1639-1640	PtRatio		1	Potential Transformer ratio (0.05 to 300)

\*These registers are preserved across power failures.

#### ConfigPasscode (1601, 1602)

The meter has an optional configuration passcode to prevent unauthorized changes to the configuration. As shipped from the factory, the ConfigPasscode is set to "0", disabling the passcode. If a passcode is set, the meter must be unlocked by writing the correct value to ConfigPasscode before any configuration registers can be changed and before the energy or demand registers can be reset to zero.

You can read the ConfigPasscode register to determine if the meter is locked. You cannot read the actual passcode itself. If you lose your passcode, contact support for assistance.

- 0 - Unlocked
- 1 - Locked

Invalid unlock attempts will result in the Modbus exception 03 - "Illegal data value", and prevent more attempts for five seconds. An unlocked meter will become locked again after five minutes or when "1" is written twice to ConfigPasscode.

The passcode can be set (or changed) by writing the new passcode to ConfigPasscode twice within 30 seconds. If a passcode is already set, the meter must be unlocked first.

Valid passcode values are:

- 0 - this disables the passcode.
- 2 to 2,147,483,647 - use at least six digits for a secure passcode.

The passcode is a 32 bit value, so both register locations 1601 and 1602 must be written when unlocking the meter or setting a passcode.

#### CtAmps (1603)

Writing the CtAmps register is a shortcut to quickly set CtAmpsA, CtAmpsB, and CtAmpsC to the same value. If you read CtAmps and CtAmpsA, CtAmpsB, CtAmpsC are all identical, then CtAmps will return the common value; otherwise it will return 0 (zero) to indicate there is no common value.

CtAmpsA, CtAmpsB, CtAmpsC (1604, 1605, 1606)

The CT amps registers are integer registers in units of amps used to set the rated current of the attached current transformers (CTs). This allows the use of different CTs on different input phases: ØA, ØB, and ØC. Rated current is the 100% value; the current that results in a 0.33333 VAC output from the CT.

The specified rated CT amps for each phase (CtAmpsA, CtAmpsB, and CtAmpsC), affect the scaling CurrentIntScale for the integer current registers CurrentA, CurrentB, and CurrentC. See section Current above for details.

CtDirections (1607)

On occasion, current transformers are installed with the label "This side towards source" facing the load instead of the source, or with the white and black wires swapped at the meter. If the electrical installer notices this, they can fix it, but sometimes the problem isn't noticed until the electrician is gone and some or all of the reported power values are unexpectedly negative.

You can correct this with the CtDirections register:

- 0 - All CTs normal
- 1 - Flip phase A CT
- 2 - Flip phase B CT
- 4 - Flip phase C CT
- 3 - Flip phase A CT and flip phase B CT
- 5 - Flip phase A CT and flip phase C CT
- 6 - Flip phase B CT and flip phase C CT
- 7 - Flip all CTs (A, B, and C)

Flipping a CT with CtDirections will also reverse the status LED indications. So if the status LED for a phase was flashing red and you flip the CT with CtDirections, the LED will change to green flashing. This cannot be used to correct for situations where CT phases do not match the voltage phases, such as swapping phases A and B on the current transformer inputs.

Averaging (1608)

The meter includes averaging for these registers: PowerSum, PowerA, PowerB, PowerC, VoltAvgLN, VoltA, VoltB, VoltC, VoltAvgLL, VoltAB, VoltBC, VoltAC, Freq, PowerFactorAvg, PowerFactorA, PowerFactorB, PowerFactorC, PowerReacSum, PowerReacA, PowerReacB, PowerReacC, PowerAppSum, PowerAppA, PowerAppB, PowerAppC, CurrentA, CurrentB, CurrentC.

Averaging is beneficial because it reduces measurement noise, and if the meter is being polled less often than once a second (say once a minute), then the average over the last minute provides a more accurate reading than just the data from the last second, which might be randomly high or low. Averaging is configured by setting the Averaging (1608) register to one of the following values:

Averaging register	Description	Averaging period	Update rate
0	Fastest	1 second	Every 1 second
1	Fast (default)	5 seconds	Every 1 second
2	Medium	20 seconds	Every 4 seconds
3	Slow	60 seconds	Every 12 seconds

When medium or slow averaging are specified, the reported values for averaged registers will only update every 4 or 12 seconds respectively, instead of once a second.

PowerIntScale (1609)

In order to report power as an integer value ( $\pm 32,767$ ), the meter must scale the power so that it doesn't overflow. By default, the meter selects a PowerIntScale value of 1, 10, 100, or 1000 whenever the CtAmps (or CtAmpsA, CtAmpsB, or CtAmpsC) are changed. The meter selects a value that won't overflow unless the power exceeds 120% of full-scale.

PowerIntScale	Power resolution	Maximum power reading
0 (default)	Auto-configure	varies
1	1 watt	$\pm 32767$ W
10	10 watt	$\pm 327.67$ kW
100	100 watts	$\pm 3276.7$ kW
1000	1000 watts	$\pm 32767$ kW
Custom Values	PowerIntScale • 1 W	$\pm (\text{PowerIntScale} \cdot 32767 \text{ W})$

You may also choose your own custom value for PowerIntScale including values that are not multiples of 10.

If PowerIntScale is set to auto-configure, then reading PowerIntScale will show the actual scale factor instead of 0.

To compute the actual power from integer power registers, use the following equation (note, there is no scaling for the floating-point power registers, which always report power in watts):

$$\text{ActualPower(W)} = \text{PowerRegister} * \text{PowerIntScale}$$

PowerIntScale is used with the following registers: PowerSum, PowerA, PowerB, PowerC, PowerReacSum, PowerReacA, PowerReacB, PowerReacC, PowerAppSum, PowerAppA, PowerAppB, PowerAppC, Demand, DemandMin, DemandMax, DemandApp.

CurrentIntScale (1622)

When reporting current values as integers, the meter scales the current values so that a current equal to the CT rated amps will result in an output value of CurrentIntScale. The default CurrentIntScale is 20000. See CurrentA, CurrentB, CurrentC for more details.

**Demand Configuration**DemPerMins, DemSubints (1610, 1611)

The variable DemPerMins sets the demand interval in minutes (default 15 minutes), and DemSubints sets the number of demand intervals (default 1). The time period of each subinterval is the demand interval divided by the number of subintervals. Setting DemSubints to 1 disables subinterval computations. The demand period cannot be longer than 12 hours (720 minutes), and a demand subinterval cannot be less than 1 minutes. The DemSubints can be set from 1 to 10.

An example configuration could use a demand period of 60 minutes with 4 subintervals. This would result in a subinterval period of fifteen minutes. Every fifteen minutes, the average power over the last hour would be computed and reported.

GainAdjustA, GainAdjustB, GainAdjustC (1612, 1613, 1614)

You may need to adjust the meter to match the results from a reference meter (such as the utility meter) or to correct for known current transformer errors. The GainAdjust registers effectively adjust the power, energy, and current calibration or registration for each phase.

The default values for the GainAdjust registers are 10,000, resulting in no adjustment. Setting the value to 10,200 increases all the power, energy, and current readings from the meter by 2% ( $10,200 / 10,000 = 102\%$ ). Setting the value to 9,800 decreases the readings by 2% ( $9,800 / 10,000 = 98\%$ ). The allowed range is from 5,000 to 20,000 (50% to 200%).

PhaseAdjustA, PhaseAdjustB, PhaseAdjustC (1615, 1616, 1617)

For maximum accuracy, there may be cases where you wish to compensate for the phase angle error of the current transformers you are using. The PhaseAdjust registers allow the phase angle to be adjusted on each phase by up to  $\pm 8$  degrees in increments of one millidegree. For example, if your CT causes a phase lead of 0.6 degrees (or 36 minutes), you could correct for this by setting PhaseAdjustA, B, and C to -600, which subtracts 600 millidegree or 0.6 degree from the phase lead. Use negative values to compensate for a phase lead in the CT (most common).

The default adjustment is -1000; this corrects for a one degree phase lead in the CT. Since our CTs typically have phase leads ranging from 0.2 degrees to 2.5 degrees, the default adjustment improves the typical performance.

CreepLimit (1618)

Creep refers to the situation where the wheel on an traditional electro-mechanical energy meter moves even though there is no power being consumed. The meter has no wheel, but all electrical systems have some noise, which can cause small readings in the absence of any power consumption. To prevent readings due to noise, if the readings fall below the creep limit, the meter forces the real and reactive power values to zero, and stops accumulating energy. This is performed independently for each measurement phase using the following equation.

$$\text{MinimumPower} = \text{FullScalePower} / \text{CreepLimit}$$

Any measured power or reactive power below MinimumPower is forced to zero. FullScalePower is defined as the nominal line-to-neutral VAC (see [Specifications](#)) multiplied by the full-scale or rated CT current.

Generally, the default value of 1500 (which sets the creep limit to 1/1500th of full-scale power) works well. Sometime, in electrically noisy environments, you may see non-zero power readings when the power should be zero. You can adjust the creep limit to eliminate this problem. For example, to adjust the creep limit to 1/500th of full-scale (0.2%), set CreepLimit to 500.

**Zeroing registers**ZeroEnergy (1620)

Writing 1 to ZeroEnergy will simultaneously set all of the energy registers to zero, except those ending in "NR" (for non-resettable). They can also be set to zero or a preset value by writing the desired value directly to each energy register. If a ConfigPasscode has been set, then you must unlock the meter before you can zero or preset the energy.

As a security measure, there are three non-resettable energy registers—EnergySumNR, EnergyPosSumNR, EnergyNegSumNR—that can never be reset to zero.

ZeroDemand (1621)

The ZeroDemand register can be written with three values (or zero which does nothing). If a ConfigPasscode has been set, then you must unlock the meter before you can zero demand.

- 1 - Zero DemandMin and DemandMax registers.
- 2 - Zero Demand, DemandA, DemandB, DemandC and DemandApp registers. Start a new demand interval.
- 3 - Zero DemandMin, DemandMax, Demand, DemandA, DemandB, DemandC and DemandApp registers. Start a new demand interval.

PtRatio (1639, 1640)

The power meter includes a potential transformer (PT) ratio configuration. This simplifies using the power meter with an external PT. PTs are used to step down medium voltage (over 600 V) to a lower voltage (commonly 120 V). For example, if you are monitoring a 4160Y/2400 service (4160 Vac line-to-line, 2400 Vac line-to-neutral), you might use a PT that steps the voltage down by a factor of 20 from 2400 Vac to 120 Vac. In this case, you would program PtRatio with a value of 20.0.

The PtRatio defaults to 1.0 and may be programmed with any ratio from 0.05 to 300. Ratios less than 1.0 may be used to monitor voltages lower than the power meter normally supports, such as a 24 Vac system (the PtRatio would be 0.2 if you used a PT to step the voltage up to 120 Vac).

When a PtRatio other than 1.0 is configured, the following measurements will be scaled by the specified PtRatio: all newly accumulated energy (active, reactive, and apparent), power, reactive power, apparent power, all voltage measurements, all demand measurements. For example, suppose the meter is

measuring 120 Vac, and 6 kW when the PtRatio = 1.0. If you change the PtRatio to 10, the readings will change to 1200 Vac and 60 kW.

Any energy accumulated before the PtRatio is changed will not be affected by the new PtRatio. For example, suppose the meter has been running for six months with PtRatio = 1.0 and has accumulated 100 kWh. If you change the PtRatio to 10, the accumulated energy will still be 100 kWh the moment after PtRatio is changed. But after changing the PtRatio, the energy may start to accumulate ten times faster, assuming the new measured power is ten times higher.

#### 7.1.3.4 Communication register list

##### Communication register list

These integer registers can be used to override the DIP switch address and baud rate settings and for more advanced communication settings, like even parity or 38400 baud. See communication registers below for details.

Registers	Name	Default	Description
1651	ApplyComConfig	0	Writing 1234 applies the configuration settings below. Reads 1 if changes not applied yet.
1652	Address *	0	Modbus address (if non-zero, overrides DIP switches)
1653	BaudRate *	0	0 = DIP switch assigned. 1 = 1200 baud, 2 = 2400 baud, 3 = 4800 baud, 4 = 9600 baud, 5 = 19200 baud, 6 = 38400 baud 7 = 57600 baud, 8 = 76800 baud, 9 = 115200 baud
1654	ParityMode *	0	0 = N81 (no parity, 8 data bits, one stop bit) 1 = E81 (even parity, 8 data bits, one stop bit)
1656	ReplyDelay *	5	Minimum Modbus reply delay: 5 to 20 ms

*\*These registers are preserved across power failures.*

Most customers will never need these registers, but they can be useful for special situations. If you are using these registers to configure multiple meters, you may want to use the broadcast address (0) so that all meters will update together. This isn't permitted for setting the address, because then multiple devices would share the same address.

The communication configuration can be restored to factory defaults by switching all the DIP switches to the OFF position and leaving them OFF for 10 seconds, then setting them to the desired address and baud rate.

##### ApplyComConfig (1651)

If any of the following communication configuration registers are changed, the new values will not take effect until "1234" (decimal) is written to this register. This makes it easier to configure multiple changes and have them all take effect together.

Reads of ApplyComConfig will return "1" if there are any pending changes, otherwise "0".

##### Address (1652)

This register can override the DIP switch address setting and also allows addresses to be assigned up to 247 (the DIP switches can only set addresses up to 63). Set this register back to zero to use the DIP switch setting.

**BaudRate (1653)**

This register overrides the DIP switch baud rate setting for speeds up to 38,400 baud.

- 0 - Use DIP switch assigned baud rate (9,600 or 19,200 baud)
- 1 - 1,200 baud
- 2 - 2,400 baud
- 3 - 4,800 baud
- 4 - 9,600 baud
- 5 - 19,200 baud
- 6 - 38,400 baud

**ParityMode (1654)**

The meter defaults to no parity, eight data bits, and one stop bit, but even parity is supported using this.

- 0 - N81 (no parity, one stop bit)
- 1 - E81 (even parity, one stop bit)

**ReplyDelay (1656)**

ReplyDelay configures a user-defined minimum Modbus reply delay between 5 and 180 milliseconds (the default is 5 milliseconds). This is useful with some Modbus master devices or software that can miss response data if the meter responds to a request too quickly.

**7.1.3.5 Diagnostic register list**

These registers, all integer registers, provide information and diagnostics for the meter. UptimeSecs and TotalSecs are 32 bit integer dual registers: the first register provides the lower 16 bits, and the second register provides the upper 16 bits of the 32 bit value. See diagnostic registers and error codes below for detailed information.

Registers	Name	Units	Description
0001 - 0002	Dummy		Dummy register. Always returns zero. Can be used to scan for active Modbus devices
1701 - 1702	Serial number *		The meter serial number
1703 - 1704	UptimeSecs	Seconds	Time in seconds since last power on
1705 - 1706	TotalSecs *	Seconds	Total seconds of operation
1707	Model *		Encoded model
1708	Version *		Firmware version
1709	Options *		Meter options
1710	ErrorStatus *		List of recent errors and events
1711	PowerFailCount *		Power failure count
1712	CrCErrorCount		Count of Modbus CRC communication errors
1713	FrameErrorCount		Count of Modbus framing errors
1714	PacketErrorCount		Count of bad Modbus packets
1715	OverrunCount		Count of Modbus buffer overruns
1716	ErrorStatus1		Newest error or event (0 = no errors)
1717	ErrorStatus2		Next oldest error or event
1718	ErrorStatus3		Next oldest error or event
1719	ErrorStatus4		Next oldest error or event
1720	ErrorStatus5		Next oldest error or event
1721	ErrorStatus6		Next oldest error or event
1722	ErrorStatus7		Next oldest error or event
1723	ErrorStatus8		Next oldest error or event

\*These registers are preserved across power failures.

SerialNumber (1701, 1702)

This is a 32 bit long integer register containing the meter's serial number, as printed on the label.

UptimeSecs (1703, 1704)

This 32 bit long integer counts the number of seconds the meter has been running since the last power failure or reset. Resets can be caused by power brownouts or severe errors.

TotalSecs (1705, 1706)

This 32 bit long integer counts the total seconds of meter operation since factory calibration.

Model (1707)

This register can be used to determine the model.

Version (1708)

This reports the meters firmware version. The firmware is not field upgradable.

Options (1709)

This register indicates factory configured options.

PowerFailCount (1711)

This counts (up to 32767) the number of times power has been cycled on this meter.

**Communication error counts**

The following four registers report communication error counts. Each register counts up to 32767 and stops. All four of these registers are reset to zero whenever power is cycled or by writing zero to any of them.

CrcErrorCount (1712)

This counts (up to 32767) the number of Modbus packets with an invalid CRC (cyclic redundancy check).

FrameErrorCount (1713)

This counts (up to 32767) the number of Modbus packets with framing errors. A framing error can indicate bad baud rate, bad parity setting, RS485 noise or interference, or an RS485 bus collision.

PacketErrorCount (1714)

This counts (up to 32767) the number of Modbus packets that could not be parsed.

OverrunCount (1715)

This counts (up to 32767) the number of times the Modbus input buffer has been overrun. The buffer is 256 bytes and normal requests are less than 80 bytes, so an overrun normally indicates non-Modbus traffic on the RS485 bus or severe noise on the bus.

## 7.2 Diagnostic LEDs

The meter includes multi-color power diagnostic LEDs for each phase to help verify correct operation and diagnose incorrect wiring. The LEDs are marked "Status" on the label. The following diagrams and descriptions explain the various LED patterns and their meanings. The A, B, and C on the left side indicate the phase of the LEDs. Values like "1.0sec" and "3.0sec" indicate the time the LEDs are lit in seconds.

**Normal startup**

On initial power-up, the LEDs will all light up in a red, yellow, green sequence. After this startup sequence, the LEDs will show the status, such as Normal Operation below.

A	Red	Yellow	Green
B	Red	Yellow	Green
C	Red	Yellow	Green
	1.0 sec	1.0 sec	1.0 sec

**Normal operation**

During normal operation, when positive power is measured on a phase, the LED for that phase will flash green. Typical flash rates are shown below.

Green	Off	Green	Off	Green	Off
-------	-----	-------	-----	-------	-----

Percent of full-scale power	LED flash rate	Flashes in 10 seconds
100%	5.0 Hz	50
50%	3.6 Hz	36
25%	2.5 Hz	25
10%	1.6 Hz	16
5%	1.1 Hz	11
1% (and lower)	0.5 Hz	5

**Zero power**

For each phase, if line Vac is present, but the measured power is below the minimum that the meter will measure (Creep Limit) the meter will display solid green for that phase.

Green**Inactive phase**

If the meter detects no power and line voltage below 20% of nominal, it will turn off the LED for the phase.

Off

### Negative power

A	Red	Off	Red	Off	Red
B	Off	Red	Off	Red	Off
C	Off	Red	Off	Red	Off

If one or more of the phase LEDs are flashing red, it indicates negative power (flowing into the grid) on those phases. The rate of flashing indicates magnitude of negative power. This can happen for the following reasons:

- This is a bidirectional power measurement application, such as a photovoltaic system, where negative power occurs whenever you generate more power than you consume.
- The current transformer (CT) for this phase was installed backwards on the current carrying wire or the white and black wires for the CT were reversed at the meter. This can be solved by flipping the CT on the wire or swapping the white and black wires at the meter. Alternatively, you can use the configuration register CtDirections (1607) to reverse the polarity of one or more of the CTs.
- The CT wires are connected to the wrong inputs, such as if the CT wires for phases B and C are swapped or the CT wires are rotated one phase.

Note: if all three LEDs are flashing red and they always turn on and off together, like the diagram for Low Line Voltage below, then the meter is experiencing an error or low line voltage, not negative power.

### Erratic flashing

A	Off	Green	Off	Red	Off
B	Red	Off	Green	Off	Red
C	Green	Off	Red	Green	Red

If the LEDs are flashing slowly and erratically, sometimes green, sometimes red, this generally indicates one of the following:

- Earth ground is not connected to the meter (the top connection on the green screw terminal).
- Voltage is connected for a phase, but the current transformer is not connected, or the CT has a loose connection.
- In some cases, particularly for a circuit with no load, this may be due to electrical noise. This is not harmful and can generally be disregarded, provided that you are not seeing substantial measured power when there shouldn't be any. Try turning on the load to see if the erratic flashing stops.

To fix this, try the following:

- Make sure earth ground is connected.
- If there are unused current transformer inputs, install a shorting jumper for each unused CT (a short length of wire connected between the white and black dots marked on the label).
- If there are unused voltage inputs (on the green screw terminal), connect them to neutral (if present) or earth ground (if neutral isn't available).
- If you suspect noise may be the problem, try moving the meter away from the source of noise. Also try to keep the CT wires as short as possible and cut off excess wire.

### Meter not operating

It should not be possible for all three LEDs to stay off when the meter is powered, because the phase powering the meter will have line voltage present. Therefore, if all LEDs are off, the meter is either not receiving sufficient line voltage to operate, or is malfunctioning and needs to be returned for service. Verify that the voltage on the Vac screw terminals is within  $\pm 20\%$  of the nominal operating voltages printed in the white rectangle on the front label.

A	Off
B	Off
C	Off

**Meter error**

If the meter experiences an internal error, it will light all LEDs red for three seconds or longer. Check the ErrorStatus (1710) register to determine the exact error. If this happens repeatedly, return the meter for service.

A	Red
B	Red
C	Red
	3.0 sec

**Bad calibration**

This indicates that the meter has detected bad calibration data and must be returned for service.

A	Red
B	Red
C	Yellow

**Line voltage too high**

A	Red	Green	Red	Green	Red	Green	Red
B	Red	Green	Red	Green	Red	Green	Red
C	Red	Green	Red	Green	Red	Green	Red
	1.0 sec						

Whenever the meter detects line voltages over 125% of normal for one or more phases, it will display a fast red/green flashing for the affected phases. This is harmless if it occurs due a momentary surge, but if the line voltage is high continuously, the power supply may fail. If you see continuous over-voltage flashing, disconnect the meter immediately! Check that the model and voltage rating is correct for the electrical service.

**Bad line frequency**

If the meter detects a power line frequency below 45 Hz or above 70 Hz, it lights all the LEDs yellow for at least three seconds. The LEDs stay yellow until the line frequency returns to normal. During this time, the meter should continue to accurately measure power. This can occur in the presence of extremely high noise, such as if the meter is too close to an unfiltered variable frequency drive.

A	Yellow
B	Yellow
C	Yellow
	3.0 sec

**Low line voltage**

If the power supply voltage is too low for the meter, the meter may exhibit one or more of the following behaviors:

- Display a continuous red, yellow, red pattern on the meter element LEDs to indicate low supply voltage.
- All LEDs go black if the voltage is too low for the meter to operate.
- The LEDs may flash erratically as the meter sporadically loses power.

A	Red
B	Yellow
C	Red

If you suspect a low supply voltage, use a DMM (multimeter) to check the applied line voltages.

**No line voltage**

A	Red	Off	Red	Off
B	Red	Off	Red	Off
C	Red	Off	Red	Off
	3.0 sec			

If the measured line voltage on all three phases is less than 20% of the nominal line Vac, then the meter will briefly flash all three status LEDs together every three seconds. This is very rare, but can indicate the following:

- You have purchased a DC instrument powered meter and the meter has power, but the circuit being monitored is off. You can check for this by measuring the AC volts from neutral to each phase or between phases for delta circuits.

The measurement circuitry has been damaged and cannot read the line voltages.

#### Other fixed pattern

If you see any other steady (non-flashing) pattern, contact VPIstruments for support.

## 7.3 Current Transformers

The 3-Phase Power Meter uses current transformers (CTs) with a full-scale voltage output of 0.33333 Vac. Split-core and bus-bar CTs are easier to install without disconnecting the circuit being measured. Solid-core CTs are more compact, generally more accurate, and less expensive, but installation requires that you disconnect the circuit to install the CTs.

The meters use CTs with built-in burden resistors generating 0.33333 Vac at rated AC current. The maximum input current rating is dependent on the CT. Check the CT label to find the maximum current rating. Exceeding the maximum input current rating may damage CTs, but should not harm the meter.

None of these CTs measure DC current and the accuracy can be degraded in the presence of DC currents, as from half-wave rectified loads. The solid-core CTs are most susceptible to saturation due to DC currents.

#### Specifications



**Please always check the label of your product for the specifications.**  
Specifications are subject to change as we are continuously improving our products.  
Please contact us to obtain the latest specification sheet.

#### Current transformers

Type	Voltage output, integral burden resistor
Output voltage at rated current	0.333 Vac (one-third volt)
CT wires	1.05 m (4 feet), twisted pair, 0.34mm <sup>2</sup> (22AWG)
Accuracy	±1% from 5% tot 120% of rated current
Phase angle	Less than 2 degrees at 50% of rated current
Insulation Voltage	600 Vac
Maximum primary voltage	5000 Vac (insulated conductor)
Operating temperature	-15..60 °C   5...140 °F
Frequency range	50-400Hz

## 8 Specification



**Please always check the label of your product for the specifications.**  
Specifications are subject to change as we are continuously improving our products.  
Please contact us to obtain the latest specification sheet.

### Current transformers

Nominal input voltage (at CT rated current) 0.33333 Vac RMS

Absolute maximum input voltage 5.0 Vac RMS

Input impedance at 60/60 Hz 23 k Ohm

### Environmental

Operating temperature -30...55 °C | -22...131 °F

Altitude Up to 2000 m | 6560 ft

Operating humidity Non-condensing, 5 to 90% relative humidity up to 40°C, decreasing linearly to 50% RH at 55°C.

Pollution Pollution degree 2. Normally only non-conductive pollution; occasionally, a temporary conductivity caused by condensation must be expected

Indoor use Suitable for indoor use

Outdoor use Suitable for outdoor use when mounted inside an electrical enclosure that is rated NEMA 3R or 4 (IP 66)

### Mechanical

Enclosure High impact, ABS and/or ABS/PC plastic

Flame resistance rating IEC FV-0

Size 143 x 85 x 38 mm | 5.63 x 3.34 x 1.50 inch

Weight 233 gram | 8.2 oz

Connectors Euroblock style pluggable terminal blocks

Green Up to 12 AWG (2.5mm), 600 V

Black Up to 12 AWG (2.5mm), 300 V

### Certifications

Safety CAN/CSA-C22.2 No. 61010-1-04; IEC 61010-1

Immunity EN 61326:2002 (Industrial locations)

Electrostatic discharge EN 61000-4-2

Radiated RF immunity EN 61000-4-3; EN 61000-4-3; EN 61000-4-4; EN 61000-4-5; EN 61000-4-6

Voltage dips, Interrupts EN 61000-4-11

Emissions FCC part 16, Class B; EN 55022 1994, Class B

### Electrical

Voltage, Maximum: 690 Vac. Exceeding this limit on any of the voltage inputs (VN, VA, VB, and VC screw terminals) can damage the power meter and void the warranty.

### Power Supply

Power Supply Voltage Range, Nominal: 100 to 600 Vac

Power Supply Input Terminals: VN, VA, VB (the meter supply can operate line-to-neutral and line-to-line)  
 Power Supply Voltage, Minimum: 85 Vac (below this voltage the meter may not operate, but will not be damaged)

Power Supply Typical Watts: see graph below

Power Supply Typical Voltage-Amperes: see graph below

Power Supply Typical Power Factor: 0.6

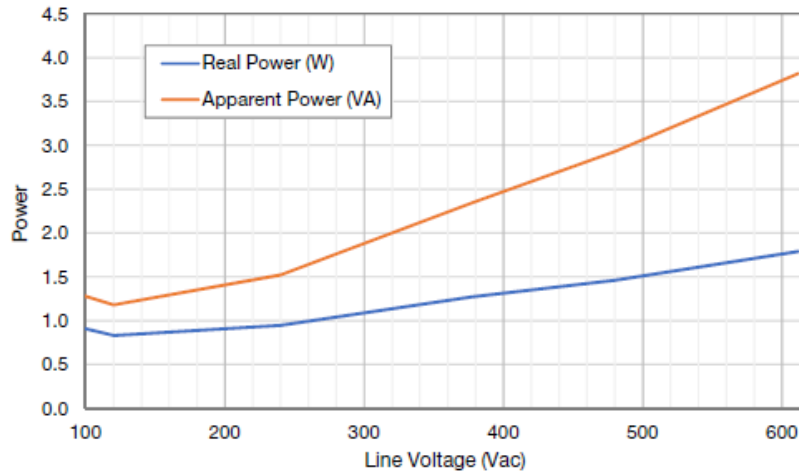

#### General Electrical

Line Frequency: 45 to 65 Hz

Line-to-Neutral Vac, Nominal: 90 to 347 Vac

Line-to-Line Vac, Nominal: 120 to 600 Vac

Over-Current Limit: 200% of rated current. Exceeding 200% of rated current will not harm the meter, but the current and power will not be measured accurately.

Maximum Surge: EN 61000-4-5: 2kV, ANSI C12.1 combination wave: 6kV, 1.2/50  $\mu$ s – 8/20  $\mu$ s

Measurement Category: The line voltage measurement terminals on the meter are rated for CAT III, 600 Vac

Measurement Category III is for measurements performed in the building installation. Examples are measurements on distribution boards, circuit-breakers, wiring, including cables, busbars, junction boxes, switches, socket-outlets in the fixed installation, and equipment for industrial use and some other equipment, for example, stationary motors with a permanent connection to the fixed installation.

#### Current Transformer Inputs

Voltage Mode:

- Nominal Input Voltage (At CT Rated Current): 0.33333 Vac RMS
- Absolute Maximum Input Voltage: 5.0 Vac RMS
- Input Impedance at 50-60 Hz: 23 k

Current Mode:

- Nominal Input Current (At CT Rated Current): 40 mA RMS
- Absolute Maximum Input Current: 200 mA RMS
- Input Impedance at 50-60 Hz: 10

#### EIA RS-485 Modbus Interface

RS-485 Output Isolation: 4500 Vac RMS

Driver Output:

- Voltage (Open Circuit):  $\pm 6$  Vdc maximum
- Voltage (54  $\Omega$  load):  $\pm 1.5$  Vdc minimum
- Current (54  $\Omega$  load):  $\pm 60$  mA typical
- Rise Time (54  $\Omega$  || 50 pF load): 900 nS typical

Receiver Input:

- Common-Mode Voltage Range: -7 Vdc to +12 Vdc maximum
- Sensitivity:  $\pm 200$  mV
- Bus Load: 1/8 unit load (up to 256 power meters per subnet)
- Failsafe Modes: bus open, bus shorted, bus idle

### Accuracy

The following accuracy specifications do not include errors caused by the current transformer accuracy or phase angle errors. "Rated current" is the current that generates a CT output voltage of 0.33333 Vac.

Condition 1 - Normal operation	
Line voltage	-20% to +15% of nominal 100 Vac to 600 Vac
Power factor	1.0
Frequency	48 - 62 Hz
Ambient temperature	23 °C +/- 5 °C
CT current	1% - 100% of rated current
Accuracy	±0.5% of reading

### Measurement

Update Rate: Approximately 0.1 second, adjusted to an integer number of AC line cycles. All measurements are performed at this rate. All measurement registers except the energy registers can update as fast as every 0.1 seconds depending on the configuration of the Averaging register. The energy registers are updated from the internal values every 1.0 second.

Start-Up Time: ≤ 1 second after the supply voltage is applied

Default CT Phase Angle Correction: 0.0 degrees. Current transformers (CTs) may have a phase angle errors, which can be corrected using the PhaseAdjust1, PhaseAdjust2, PhaseAdjust3 registers.

Creep Limit: Defaults to 0.04% (1/2500th) of full-scale.

Nominal Voltage: 347.0 Vac line-to-neutral (this value is used by the VoltsNoiseFloor, CreepLimit, and PowerIntScale)

## 9 Order information and accessories

Model	Description
VPA.8000.WRMB	3-Phase power meter - Wide-Range Modbus
VPA.8075.0100	Current Transformer 100A, 0.333V output
VPA.8125.0200	Current Transformer 200A, 0.333V output
VPA.8125.0400	Current Transformer 400A, 0.333V output
VPA.8200.0600	Current Transformer 600A, 0.333V output
VPA.8200.1000	Current Transformer 1000A, 0.333V output
VPA.8200.1500	Current Transformer 1500A, 0.333V output

## 10 Energy Monitoring Applications

3-Phase Power Meter can be connected to VPVision. VPVision is the complete real time energy monitoring solution for all utilities within your company. Get real-time data on your usage and see the patterns on your supply and demand side.

Take factual and well-founded decisions on your costs and investments.

Reveal the consumption of all utilities, including compressed air, technical gases, steam, vacuum, natural gas, electricity, wastewater, heating fuels etc.

VPVision enables you to view data on any platform; from PC to smartphone. It will help your organization raise the energy awareness among your staff.

It will be your guiding hand to target energy savings for individuals, teams or at company-wide level.



## 11 Appendix A - Federal Communications Commission (FCC) Statement

This equipment has been tested and complies with the limits for a Class B digital device, pursuant to part 15 of the FCC Rules. Operation is subject to the following two conditions: (1) This device may not cause harmful interference, and (2) this device must accept any interference received, including interference that may cause undesired operation.

The FCC limits are designed to provide reasonable protection against harmful interference in a residential installation. This equipment generates, uses and can radiate radio frequency energy and, if not installed and used in accordance with the instructions, may cause harmful interference to radio communications. However, there is no guarantee that interference will not occur in a particular installation. If this equipment does cause harmful interference to radio or television reception, which can be determined by turning the equipment off and on, the user is encouraged to try to correct the interference by one or more of the following measures:

- Reorient or relocate the receiving antenna.
- Increase the separation between the equipment and receiver.
- Connect the equipment into an outlet on a circuit different from that to which the receiver is connected.
- Consult the dealer or an experienced radio/TV technician to help.

## 12 Appendix B - Measurement troubleshooting

There are a variety of possible measurement problems. The following procedure should help narrow down the problem. This assumes you can communicate with the meter and read registers. You can combine these diagnostic steps with the status LED diagnostics.

### Voltage

Start by checking the reported voltage (VoltA, VoltB, VoltC) for active (connected) phases. Make sure the voltages match the expected line-to-neutral voltages (or line-to-ground for delta circuits). You should check the actual voltages present at the meter with a multimeter if possible.

- If one or more voltages are zero, then you either have a wiring problem or something is wrong with the meter. Verify the actual voltages with a multimeter. In rare cases, with delta circuits, one phase may be grounded and will read zero volts.
- If one or more voltages are too low (by more than 5%), then make sure you have the correct model. For example, a VPA.8000.Y208 expects line-to-neutral voltages of 120 Vac and can measure up to about 150 Vac. If you apply 208 Vac line-to-neutral, the meter will read a voltage in the 150 Vac to 180 Vac range.
- If any voltages read high, then check your wiring. If the wiring is correct, contact support.
- If the voltages are close to the measured (or expected) values, continue with the next step.

### Power

Next, check the measured power for each active phase (PowerA, PowerB, PowerC). If possible, estimate or measure the actual power. Also, make sure the load you are measuring is currently on.

- If one or more active phases are reporting zero power, then the problem is probably one of the following:
  - There is no active power (the load is off) or the power is too low to measure (generally less than 1/1000th of full-scale).
  - CT wires are not securely connected.
  - The CT or its wires are damaged.
  - There is strong electrical interference, as might occur if the meter is in very close proximity to a variable speed drive (also called variable frequency drive or inverter).
  - The meter is not working correctly: try swapping it with a replacement meter.
- If one or more active phases are reporting negative power:
  - The current transformer has been installed backward on the wire being measured. CTs are marked with either an arrow or a label saying "This side toward source". If the arrow or label are not oriented toward the source of power (generally the panel or breaker), then the measured current will be inverted and the power negative. This can be fixed either by flipping the CT or by swapping the white and black wires where they enter the meter.
  - The current transformer white and black wires have been swapped where they enter the meter (at the black screw terminal block).
  - The line voltage phases (green screw terminals) are not matched up with the current phases (black screw terminals). For example, the phase A CT is around the phase B wire.
  - This may be normal if you are measuring in an environment where power may be consumed or generated, such as a house with PV panels.
- If one or more phases are reporting low or high power:
  - Make sure the CtAmps configuration is set correctly for your current transformers.
  - The current transformers may have a rated current too high or too low for your application. CTs should be used between 10% and 100% of their rated current for best results. They generally work with reduced accuracy as low as 0.5% to 0.1% of rated current.
  - The CTs may not be installed properly. Check for: CTs touching each other or pre-existing CTs; CT opening too large for the conductor being measured.
  - The voltage phases (green screw terminal block) are not matched up with the current phases (black screw terminal block). The easiest way to determine this is to skip ahead to the next troubleshooting section: Power Factor and Reactive Power.
  - Interference from a variable frequency or variable speed drive: VFD, VSD, inverter, or the like. Generally, these drives should not interfere with the meter, but if they are in very close proximity, or if the CT leads are long, interference can occur. Try moving the meter at least three feet (one meter) away from any VFDs. Use short CT leads if possible. NEVER install the meter downstream of a VFD: the varying line frequency and extreme noise will cause problems!
  - Our current transformers can only measure AC currents. Strong DC currents will saturate the magnetic core of the CT, preventing an accurate measurement of the AC current. The overwhelming majority of AC powered electric devices do not draw significant DC current, so this is a rare occurrence.

- Loads with a high current crest factor (ratio of the peak current to the RMS current) can cause clipping in the measurement circuitry, resulting in lower than expected readings. You can check for this with a handheld power quality analyzer that can measure crest factor (CF) or by trying a CT with a higher rated current, which should allow the meter to measure the peak current accurately.
- The CTs may be malfunctioning. If possible, use a current clamp to verify the current, then use a multimeter to measure the AC voltage between the white and black wires from the CT (leave them connected to the meter during this test). At rated current, the CT output voltage should equal 0.333 Vac (333 millivolts AC). At lower currents, the voltage should scale linearly, so at 20% of rated current, the output voltage should be  $0.20 * 0.333 = 0.0666$  Vac (66.6 millivolts AC).
- If possible, verify the expected power with a handheld power meter. Current clamps can be useful to very roughly estimate the power, but since they measure current, not power, the estimated power (voltage times current) may be off by 50% or more.

### Power Factor and Reactive Power

The measured power factor and reactive power are very useful in determining if there is a phasing mismatch between the voltage and current measurement phases on the meter. For example, if the phase A CT is around the phase B wire.

However, this troubleshooting is complicated because different loads have different typical power factors and the power factor can vary significantly for some devices, like motors, as a function of the mechanical load on the motor. Here are some general guidelines:

- Motors, idling or with a light load: power factor from 0.1 to 0.6, positive reactive power.
- Motors, normal or heavy load: power factor from 0.5 to 0.8, positive reactive power.
- Motor with VSD: power factor between 0.5 and 0.9.
- Incandescent lighting: power factor near 1.0, small negative reactive power.
- Florescent lighting: power factor between 0.4 and 1.0.
- Electrical heating: power factor near 1.0.
- Office equipment: power factor between 0.6 and 1.0, reactive power may be positive or negative.

Negative power factor values either indicate you are generating power (as with a PV system) or that the CTs are reversed.

If the measured power factor or reactive power appears to be outside the normal ranges, this most commonly indicates that the voltage and current phases on the meter are not connected properly, although some loads fall outside the normal ranges. Check the following:

- The CT connected to the ØA CT terminal is installed around the line wire being measured by the ØA Vac terminal (green terminal block).
- The CT connected to the ØB CT terminal is installed around the line wire being measured by the ØB Vac terminal (green terminal block).
- The CT connected to the ØC CT terminal is installed around the line wire being measured by the ØC Vac terminal (green terminal block).

If this doesn't solve your problem, contact technical support for more assistance.

## 13 Appendix C - Maintenance

### **Maintenance and Repair**

The meter requires no maintenance. There are no user serviceable or replaceable parts except the pluggable screw terminals.

The meter should not normally need to be cleaned, but if cleaning is desired, power must be disconnected first and a dry or damp cloth or brush should be used.

The meter is not user serviceable. In the event of any failure, the meter must be returned for service using our RMA form. In the case of a new installation, follow the diagnostic and troubleshooting instructions before returning the meter for service, to ensure that the problem is not connection related.

## Notes

## Notes

energy insights trusted by professionals™

**Trido Energy Services**

#1425 407 2nd Street SW,  
Calgary, AB T2P 2Y3  
Canada  
info@tridoes.com  
www.trodes.com

MAN-VP-AKW-EN-2500

Date: 15-04-2025

