

SELECTION CRITERIA

- Fresh water use
 - Pilot operated
 - Actuation by pressure
 - 150 PSI water pressure rating
- Flanged end connections
 - 3-Way configuration
 - 6" & 8" sizes
 - 225 PSI proof pressure

CONSTRUCTION DETAILS

- Brass & stainless steel internals
 - Buna-N diaphragms & seals
- Cast Iron body & bonnet
 - Flange: ANSI B16.1 Class 125 lbs.

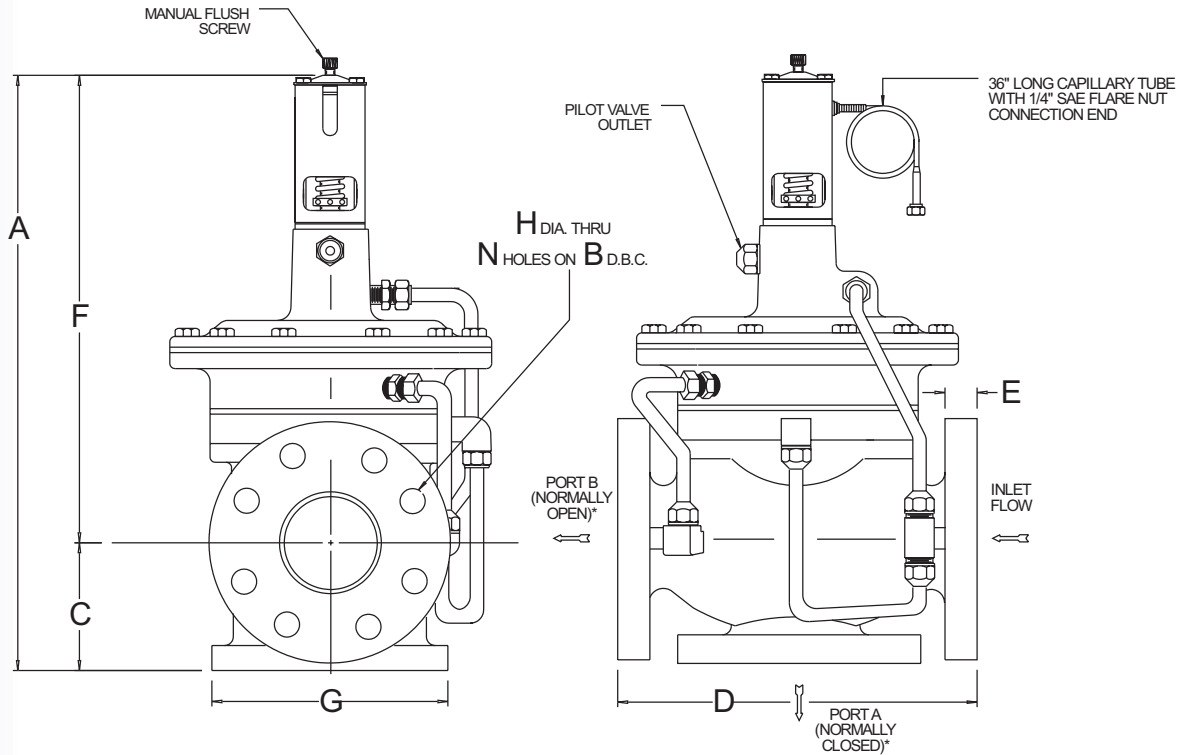

*NOTE: Normally closed valves open on pressure increase, normally open valves close on pressure increase.

Reference Metrex drawing MDFPR-3000-3W

VALVE SIZING CHART

VALVE PART NUMBER	PIPE SIZE	C _v	DIMENSIONS						FLANGE DATA			APPROX. SHIP WT.
			A	G	C	D	E	F	B	H	N	
MDFPR-3150-FL-3W	6"	SEE TABLE 1	26.8"	11"	7-7/8"	20"	1"	18.9"	9-1/2"	7/8"	8	460#
MDFPR-3170-FL-3W	8"	SEE TABLE 1	32-3/8"	13-1/2"	10-3/8"	25-1/2"	1-1/8"	22"	11-3/4"	7/8"	8	680#

ORDERING INFORMATION

- Use the valve sizing chart on the preceding page, tables, and charts below to determine the complete part number.

BASIC PART NO.: MDFPR -3 -FL-3W-



BELLOWS OPTIONS

- The optional ammonia actuator is designated by an "A" after the R.

Example: MDFPRA-3150-FL-3W.

The optional 1/4" male SAE flare fitting for refrigerant pressure connection is designated by an "F" after the R. The 1/4" SAE flare fitting replaces the 36" long capillary tube with 1/4" SAE flare nut connection.

Example: MDFPRE-3170-FL-3W.

PRESSURE RANGE ADJUSTMENT

- The refrigerant pressure at which the valve begins to open can be adjusted from 70 to 260 PSI. A 25 PSI increase of pressure is required to open the valve fully. Minimum required differential pressures are listed in TABLE I.

TRIM SELECTION

- TABLE 1 shows Cv for available trim for each size valve. If no trim is specified, TA trim is provided.

TABLE I				
VALVE PART NUMBER	TRIM DESIGNATOR	PIPE SIZE	C _v	MIN. Δ P
MDFPR-3150-FL-3W-TA	TA	6"	360	5
MDFPR-3150-FL-3W-TB	TB	6"	220	5
MDFPR-3170-FL-3W-TA*	TA	8"	670	4

*NOTE: On 8" valve maximum differential pressure is 25 PSI.

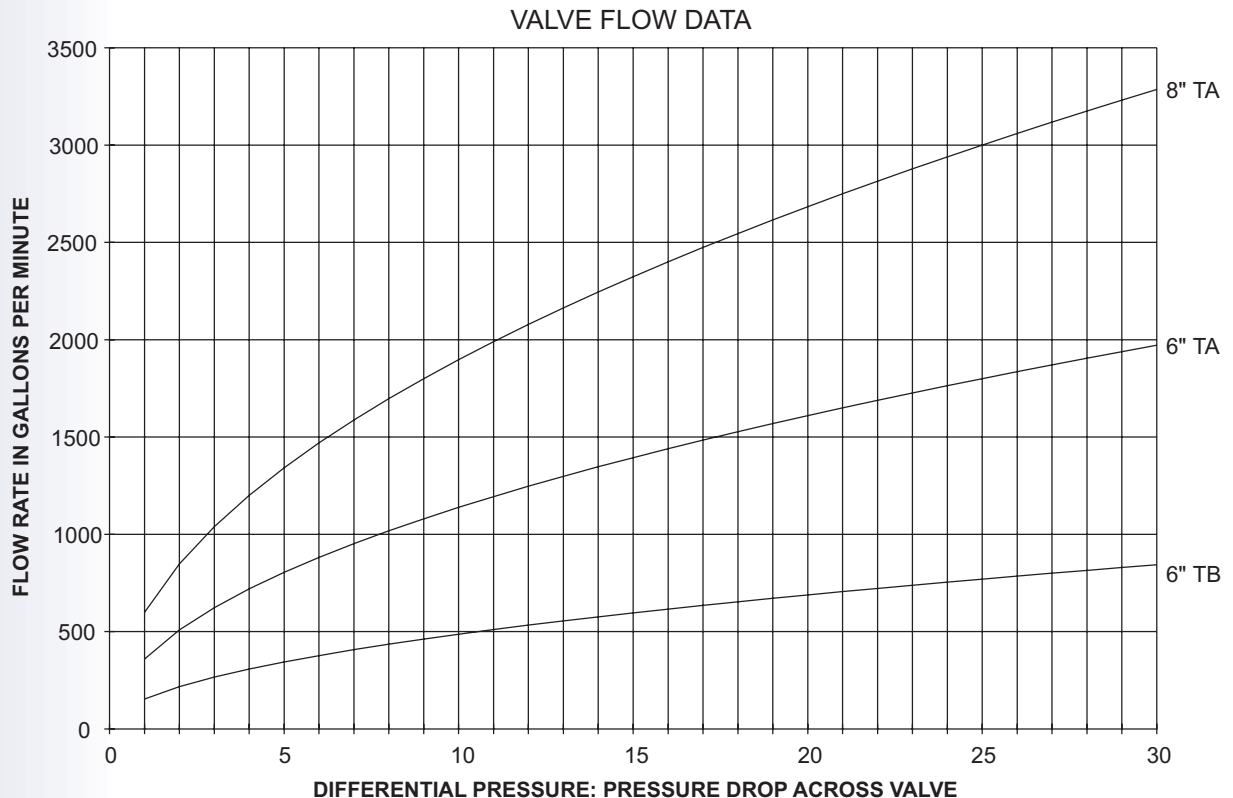

INSTALLATION INSTRUCTIONS

PAGE 3 OF 4

- 1) All valves should be mounted vertically on a horizontal water line.
- 2) Connect the incoming water line to the valve inlet. Direction of water flow (see drawing) is indicated by the arrow cast on the side of the valve body.
- 3) Connect condenser water line to bottom outlet of valve body.
- 4) Connect bypass line to bypass outlet.
- 5) Connect capillary tube (1/4" flare nut) to refrigerant head pressure connection on condenser.
Note: For ammonia service, steel bellows assembly with 1/4" male flare connection furnished in lieu of capillary tube.
- 6) Connect pilot valve outlet drain fitting (item 46) to a 3/8" line and plumb with minimum flow restrictions. Suitable connections include: downstream of condenser, balance valve or in common line downstream or tee; sump reservoir, drain to sewer or suction side of circulating pump

Important: A pressure drop of at least (see Table I) from valve inlet to pilot outlet is required for condenser port to go full open.

3-WAY HEAD PRESSURE REGULATOR TYPICAL APPLICATION

DIVERTING VALVE UPSTREAM OF CONDENSER:

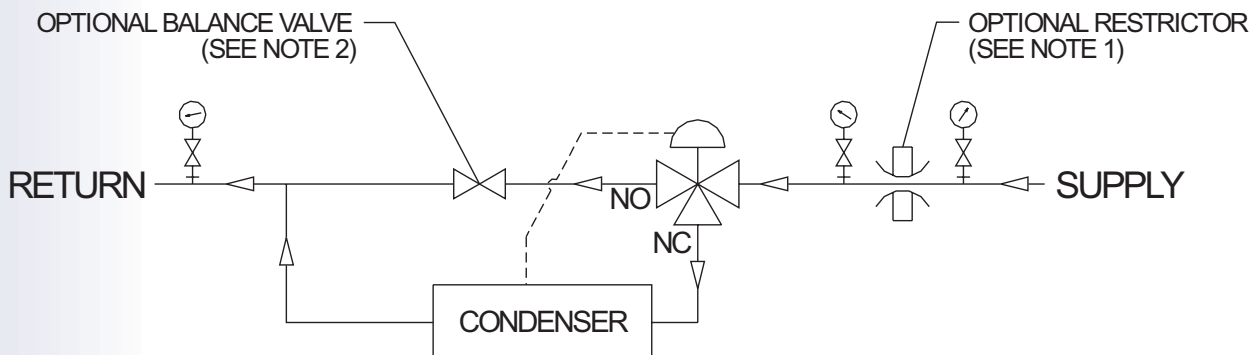

NOTES:

- 1) Restrictor Option: Recommended for use in systems with high pressure drop, high pump pressure supply, or large pressure differential between supply and return: >25-35 PSI. Consists of an orifice plate or plug valve sized/set to produce a pressure drop and reduce flow to a condenser and water regulating valve. May be placed anywhere in common line upstream or downstream of the condenser and a valve that sees total circuit flow. Proper sizing of restriction reduces high velocity flow across valve seat and eliminates requirement for special internal trim sizes.
- 2) Balance Valve Option: Used to equalize circuit resistance in both valve legs so that total resistance and flow does not vary with change in valve opening. Also used to help produce minimum required pressure differential between valve inlet and downstream pilot drain line connection (not shown). Consult valve application information for pilot operated valves.

OPERATION INSTRUCTIONS

- 1) Start incoming water flow and the system water will flow through the external tubing into the chambers under the lower diaphragm and above the upper diaphragm. The force exerted by the upper diaphragm, due to the larger effective area, will overcome that of the lower diaphragm and the valve will automatically switch from condenser to by-pass flow. The by-pass water pressure is ported to the chamber between the upper and lower diaphragms.
- 2) To flush the valve through condenser outlet, independent of head pressure setting, insert an allen wrench into the manual flush screw and turn clockwise until the screw bottoms. After flushing, reverse this procedure for automatic operation. Caution: If the screw is not unscrewed or backed off sufficiently to clear the top plate on the bellows housing after flushing, the pilot valve will not close.
- 3) To switch water flow to condenser, sufficient actuating head pressure is required to overcome the tension on the power spring. The MDFPR model is a multi-range valve with refrigerant pressure range adjustable from 70-260 PSI. The valve controls the flow rate of water in response to changes in signal pressure (refrigerant pressure) to its pilot. The condenser port opens on increasing refrigerant pressure and closes on decreasing pressure as the by-pass port is closing on increasing pressure and opening on decreasing pressure. The refrigerant pressure acting upon the bellows exerts a force opposed by the power spring and modulating spring. Increasing refrigerant pressure overcomes the spring forces, and opens the pilot valve assembly. As the flow past the pilot valve exceeds the flow past the metering orifice, the condenser port begins to open, compressing the modulating spring. As the modulating spring is compressed, its increased force reduces the pilot valve opening until the flow from the cover equals the flow into the cover. The main valve is now held at a fixed position that is determined by the refrigerant pressure. Decreasing refrigerant pressure results in the pilot valve lift decreasing, causing the condenser port to begin to close until the modulating spring force has decreased to match the change in refrigerant pressure bellows force. The "feedback" action of the modulating spring causes the main valve to hold a position proportional to the refrigerant pressure, and results in a very stable control valve allowing only the flow necessary for an efficient operating system.
- 4) To increase the actuating refrigerant head pressure, insert a pin or hex key into the adjustment nut and turn counter-clockwise. To lower actuating refrigerant head pressure, turn adjustment nut clockwise.
- 5) The metering orifice controls water flow to the pilot and upper diaphragm, and has been calibrated to give the proper flow throughout all pressure ranges normally encountered in such systems. Other than head pressure settings, there are no external adjustments required for automatic operation of the valve.

MAINTENANCE INSTRUCTIONS

Water to the valve must be clean and free of foreign particles. If the water supply is dirty, a strainer should be installed upstream of the valve and cleaned as often as is necessary. Foreign particles, if carried through the pilot passages, may tend to obstruct the metering orifice or restrictor and prevent the valve from closing. External tubing

including the metering orifice or restrictor should be cleaned periodically.

It is recommended that the valve be disassembled and inspected for wear or corrosion at a minimum of 2 year intervals, depending on service conditions. Complete rebuild kits are available from Metrex Valve.