



2" (50 mm) HS4D with Optional Beacon Pilot Lights and Optional DIN Connector

## INTRODUCTION

The HS4D Two Step Solenoid Valve is based on the same strength, reliability, design principles and craftsmanship as the standard Hansen HS4A Solenoid Valve—with added versatility and safety. The use of two step solenoid valves may help to reduce the potential for hydraulic shock. Please refer to IAR bulletin number 116.

The two step solenoid design provides two opening positions for the valve: soft opening/soft closing position (10% rated flow) and fully open. These valves are normally closed and will revert to the closed position in the event of a power failure. Full flow capacity is the same as the standard Hansen HS4A. This makes it ideal for drop-in replacement of existing solenoid valves. Similar to the standard HS4A, the HS4D is superior in its ability to overcome dirt and sticky oil during opening, as well as function in an oil-free “dry” system.

## APPLICATIONS

The Hansen HS4D is a reliable, rugged-bodied valve that can be used anywhere a soft opening or closing solenoid valve is desired. The HS4D should not be applied as a two capacity valve for liquid feed applications, but rather as a soft opening/soft closing valve. The partially open position is designed to gradually introduce liquid flow before switching to the fully open position. Additionally, the two step solenoid valve can be used to gradually slow liquid flow prior to fully closing the valve to minimize hydraulic shock. When used as a hot gas defrost valve, the partially open position allows gradual equalization of hot gas during defrost before fully opening the valve.

The HS4D can also be used as a suction solenoid and equalizing valve. After the conclusion of defrost, the partially open valve position can equalize (bleed) gas from the evaporator. After proper bleed time, the valve can be placed in the Full Open position.

## Specifications, Applications, Service Instructions & Parts

### HS4D TWO STEP SOLENOID VALVES

Flanged and Weld-in  
3/4" thru 4" Port  
(20 mm thru 100 mm)  
for Refrigerants



## KEY FEATURES

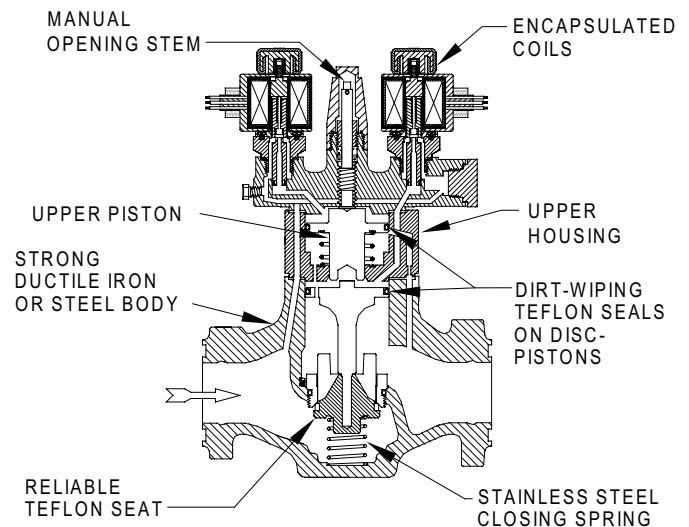

## ADDITIONAL FEATURES

- “Soft” opening and closing
- Tolerant of dry systems
- Teflon main & pilot seats
- Heavy duty, pilot operation
- 300 psi MOPD (20 bar), 500 psi (34 bar) for CO<sub>2</sub>
- Simple serviceable design
- Available close-coupled strainer/check valve
- CSA certified
- CE available
- Beacon pilot lights available
- Flange-to-flange drop-in replacement for standard HS4A
- Flanged or weld-in valve body available
- All Hansen manual opening stems are “OUT” for automatic operation

## MATERIAL SPECIFICATIONS

Body: Ductile iron, ASTM A536 (Flanged valves)

Steel, ASTM A352 LCB (Weld-in valves)

Adapter: Ductile iron, ASTM A536

Upper Piston: Ductile iron, ASTM A536, disc type, spring energized teflon seal

Main Piston: Steel, disc type, spring energized teflon seal

V-Port/Seat:

Ductile iron with teflon seat

Main Seat:

Stainless steel, removable (integral ductile iron for flanged 3/4" thru 1 1/4")

Upper Housing: Ductile iron, ASTM A536

Gaskets: Non-asbestos, graphite composite

Manual Opening Stem: Steel, plated

Solenoid Tube: Stainless steel

Solenoid Plunger: Stainless steel

Pilot Orifice: Stainless steel

Flanges: Forged steel, ASTM A105

Max. Opening Pressure Differential (MOPD):

300 psi (20 bar), 500 psi (34 bar) for CO2

Safe Working Pressure: 400 psig (28 bar),

600 psig (40 bar) for CO2

Operating Temperature: -60°F to +240°F

(-50°C to +115°C); (Lower temperatures possible at pressure down-ratings)

## ADVANTAGES

These valves combine modern design and materials with advanced manufacturing techniques and quality control to offer a significantly superior and reliable product. Their ductile iron or steel bodies are stronger and more rugged than common cast iron, including semi-steel (class B iron) valves. They are more dirt resistant than full skirted piston designed valves. They use standard, power saving, low wattage coils that can be used on all valve sizes. All valves incorporate reliable teflon seating and stainless steel spring closing. Main seats are stainless steel on 1 1/2" and larger valves. All valves use a spring activated, teflon, dirt-wiping piston seal. Manual opening stems are located on top of valves, up and away from dirt and rust particles to extend stem seal life. This also facilitates easier insulating of valves. Each valve is individually packaged and sealed for valve interior cleanliness and ease of storage until ready for use.

## INSTALLATION

Protect the interior of valve from dirt and moisture during storage and installation. Valve should be installed so that the arrow on the valve body is in direction of normal refrigerant flow. Valve will not prevent reverse flow; use close-coupled check valves where necessary. System should be free from dirt, weld slag and rust particles. A 60 mesh, close-coupled strainer is available for installation at inlet of valve; no small internal screens are used. Optional 100 mesh screen available; 3/4" thru 2 1/2".

Pipe sizing, rating, anchoring, and similar prudent precautions should be taken to ensure "liquid hammer" will not occur when valves open or close. For proper flange gasket sealing, care must be taken when threading or welding to ensure flanges are parallel to each other and perpendicular to pipe. Also, gaskets should be lightly oiled and all bolts must be tightened evenly. Weld-in-line valves can be installed without disassembly, with manual opening stem in open position. Cover the solenoid coils to prevent weld splatter from damaging the over-molding.

Welds should be annealed as necessary in accordance with good practice. Supplementary painting of valves and welds is recommended for complete corrosion protection. Pipe covering, where applied, should have proper moisture barrier. Before putting valves into service, all pipe connections, valve seats and seals should be tested for leaks at pressure levels called for in appropriate codes.

## ELECTRICAL

The coils draw 16 watts and will operate properly between 85% and 110% of rated voltage (24V coil draws 19 watts). Standard coil connection is a 1/2" fitting (NPSM) for conduit, with two 18" wire leads and ground wire. Coils with combination DIN plug with NPSM thread and cable clamp are available; contact factory. All coils are totally encapsulated and meet NEMA4 (splash proof, IP65) requirements. The coil should only be energized while on the solenoid tube. Otherwise, immediate coil burnout may occur. To avoid bending the solenoid tube, remove the coil from valve before connecting any electrical conduit. Wireless Beacon pilot lights are available. (See page 16).

## COIL OPTIONS AVAILABLE

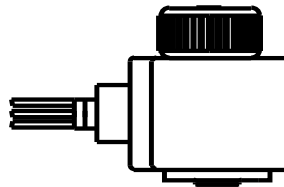

STANDARD LEADED WIRE WITH 1/2" NPSM CONNECTION

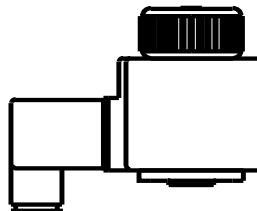

PLUG-IN COIL WITH DIN CONNECTOR FOR CABLE OR 1/2" NPSM CONNECTION

# HS4D TWO STEP SOLENOID PRINCIPLES OF OPERATION

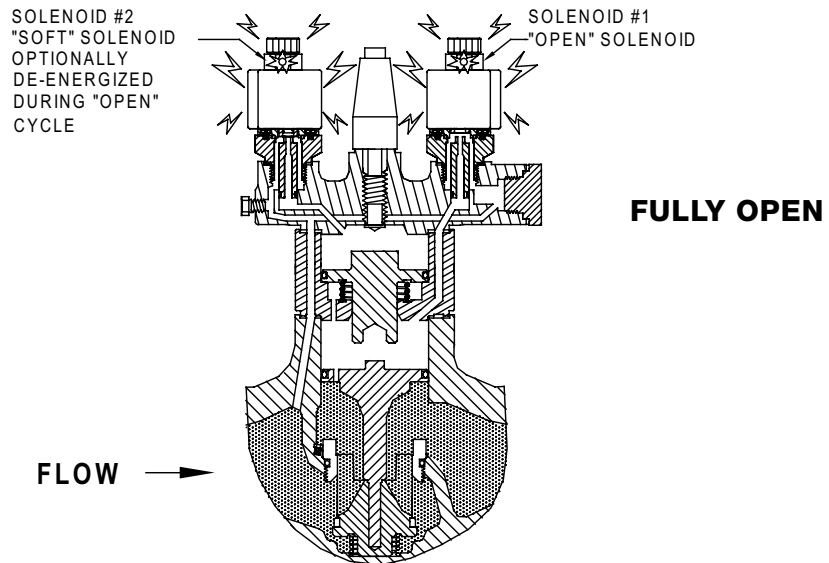
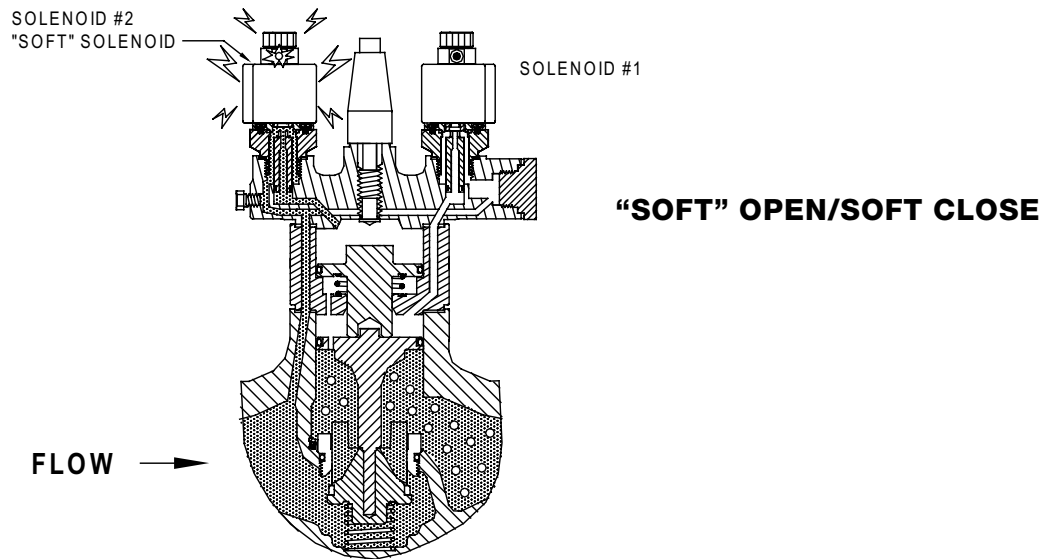
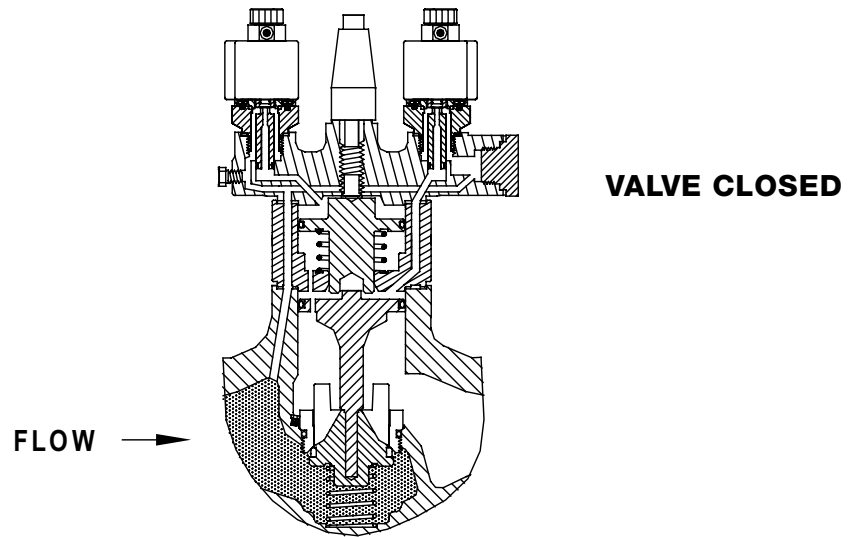

## HS4D TYPICAL WIRING DIAGRAM

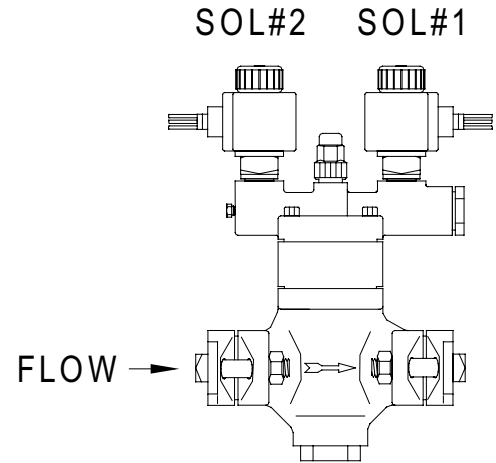
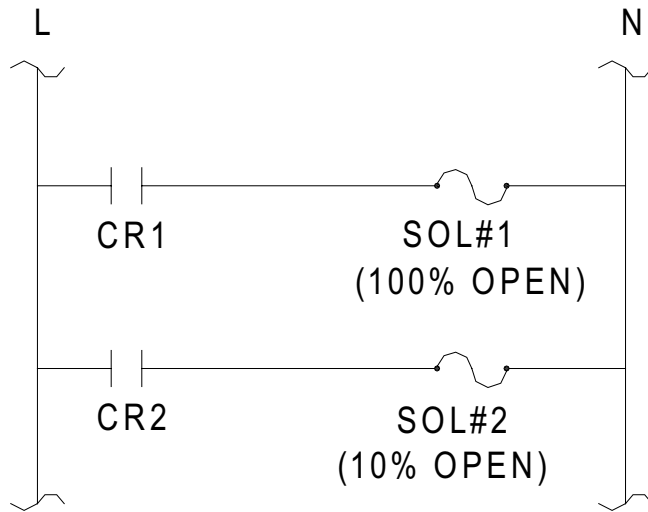

### NOTES:

1. SOLENOID COIL #2 OPENS VALVE 10%.
2. SOLENOID COIL #2 IS ALWAYS MOUNTED ON THE INLET SIDE OF VALVE.
3. SOLENOID COIL #1 OPENS VALVE FULLY.
4. SOLENOID COIL #2 DOES NOT HAVE TO BE ENERGIZED FOR COIL #1 TO FULLY OPEN VALVE.

## TYPICAL APPLICATIONS FOR HOT GAS DEFROST WITH TWO STEP SOLENOID VALVES AND SELF-EQUALIZING SUCTION STOP VALVES

These are only examples of possible control valve schemes. As always, they are provided only to assist system designer in applying and selecting valves and controls. Ultimately, designer is responsible for safe and satisfactory operation of any defrost system.

### BOTTOM FEED EVAPORATOR

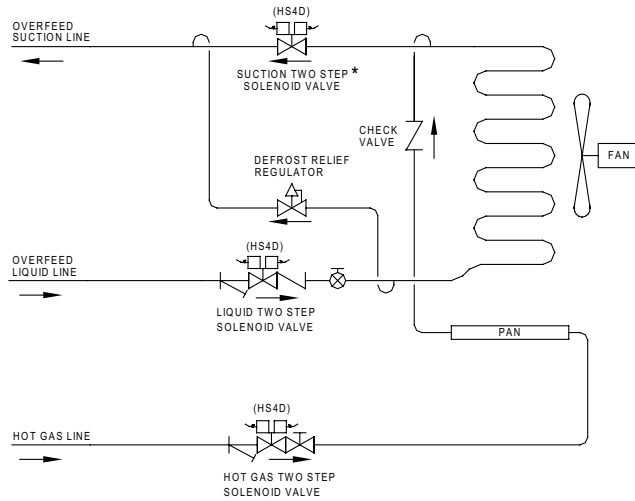

### TOP FEED EVAPORATOR

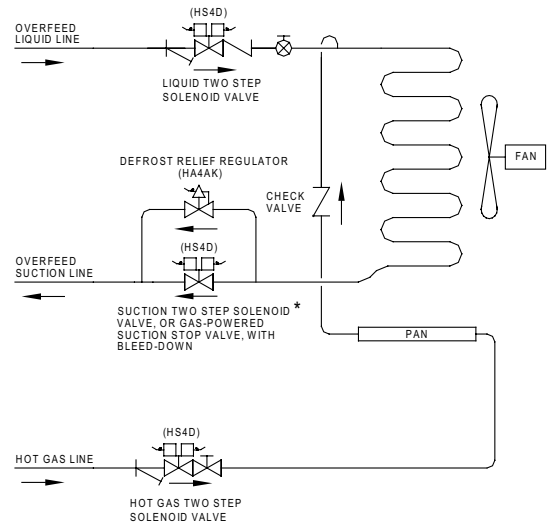

### EVAPORATOR WITH GAS-POWERED SUCTION STOP VALVE

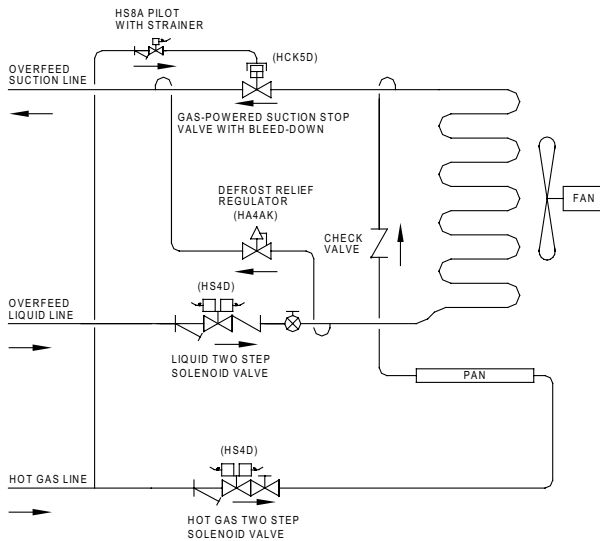

### EVAPORATOR WITH DEFROST CONDENSATE LIQUID DRAINER

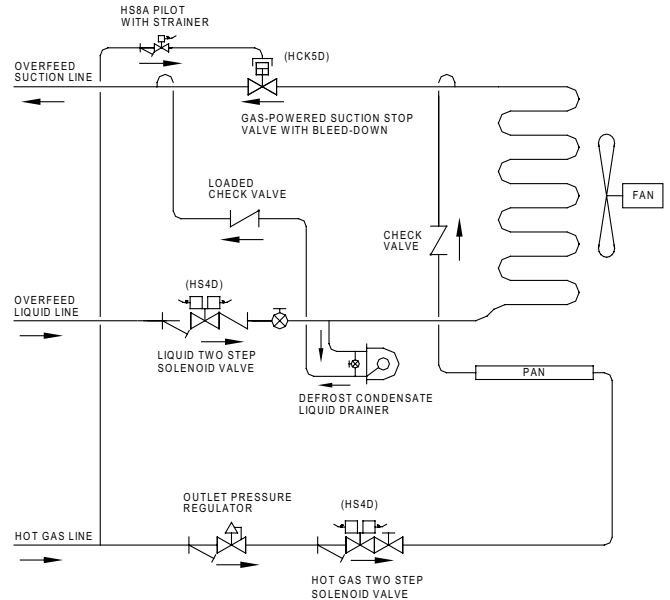

\*For suction closure at temperatures below 0°F (-18°C) alternate low pressure drop valves are preferably used such as Hansen Gas-Powered Suction Stop Valve Type HCK2, HCK5, HCK5D and HS9B.

## HIGH PRESSURE LIQUID VALVE CAPACITIES - TONS

PORT SIZE INCHES	R717		R22		R134A		R507	
	Pressure Drop (ΔP) PSID		Pressure Drop (ΔP) PSID		Pressure Drop (ΔP) PSID		Pressure Drop (ΔP) PSID	
	2	4	2	4	2	4	2	4
3/4"	139	197	28	39	26	36	17	24
1"	255	360	51	72	47	66	32	45
1 1/4"	357	505	71	101	65	93	44	63
1 1/2"	762	1078	152	215	140	198	95	134
2"	1023	1447	204	289	180	265	127	180
2 1/2"	1676	2371	335	474	308	435	208	295
3"	2264	3202	452	640	415	587	281	398
4"	3614	5111	722	1021	663	938	449	635

Note: Ammonia capacities are based on 86°F liquid temperature, 20°F evaporator temperature, and no flashing through the valve. Halocarbon capacities are based on 95°F saturated liquid temperatures and 20°F evaporator temperature.

## PUMPED LIQUID VALVE CAPACITIES - TONS - 1:1 RECIRCULATION

PORT SIZE INCHES	R717		R22		R134A		R507	
	Pressure Drop (ΔP) PSID		Pressure Drop (ΔP) PSID		Pressure Drop (ΔP) PSID		Pressure Drop (ΔP) PSID	
	2	4	2	4	2	4	2	4
3/4"	176	248	41	58	40	56	32	45
1"	320	452	75	107	73	103	58	82
1 1/4"	448	636	106	149	102	144	81	115
1 1/2"	960	1356	225	319	218	308	173	244
2"	1288	1824	303	428	293	414	232	328
2 1/2"	2112	2984	496	701	480	678	380	538
3"	2852	4032	670	947	648	916	514	726
4"	4552	6436	1069	1511	1034	1462	820	1159

Note: Pumped liquid line capacities are based on 0°F liquid temperature and 0°F evaporator temperature. For evaporator temperatures between -40°F and 40°F, capacities are within 5% for ammonia and ±10% for halocarbon refrigerants.

### Sizing Valve Based on Recirculation Rate

Table is for 1:1 recirculation rate. For higher recirculation rates, multiply required capacity by the recirculation rate and select port size from table. (ie. for a 30 ton ammonia evaporator coil and 4:1 recirculation rate, multiply 4x30=120 tons and select closest port size; 3/4" port with 2 psid pressure drop)

## HOT GAS DEFROST NOMINAL VALVE SIZING CAPACITIES - TONS

(Defrosting Evaporator Size Tons)

APPLICATION	REFRIGERANT	PORT SIZE INCHES					
		3/4"	1"	1 1/4"	1 1/2"	2"	2 1/2"
Hot Gas Solenoid*	R717	9 to 15	15 to 28	28 to 39	39 to 73	73 to 106	106 to 165
	R22, R134a, R507	6 to 8	8 to 15	15 to 20	20 to 32	32 to 47	47 to 75

\* Or an outlet pressure regulator with electric shut-off (HA4AOS).

Evaporator tons at 10°F TD (temperature differential), valve capacities are conservative. These capacities can be modified up or down depending on type of evaporator, temperature, mass, frost thickness, defrosting time, etc. Typical for -20°F evaporator.

## SUCTION VAPOR CAPACITIES - TONS

(1 Ton = 12,000 Btu/hr = 3.517kW = 3024 kcal/hr)

PORT SIZE INCHES	CV	PRESSURE DROP ACROSS VALVE	R717				R22			
			EVAPORATING TEMPERATURE				EVAPORATING TEMPERATURE			
			-20°F†	0°F	+20°F	+40°F	-20°F	0°F	+20°F	+40°F
¾"	6.4	2 psi	6.4	7.4	9.5	12	2.8	2.8	3.6	4.4
		5 psi	9.7	8.7	15	19	4.3	4.4	5.5	6.9
1"	11.7	2 psi	12	13	17	22	5.2	5.2	6.5	8.0
		5 psi	18	16	27	34	7.9	8.0	10	13
1¼"	16.4	2 psi	16	19	24	31	7.2	7.2	9.1	11.3
		5 psi	25	22	38	48	11	11	14	18
1½"	35	2 psi	35	40	52	65	15	15	19	24
		5 psi	53	48	81	102	24	24	30	38
2"	47	2 psi	47	54	70	87	21	21	26	32
		5 psi	71	64	108	137	32	32	41	51
2½"	77	2 psi	77	89	114	143	34	34	43	53
		5 psi	116	105	177	224	52	53	67	83
3"	104	2 psi	104	120	154	193	46	46	58	71
		5 psi	157	187	239	303	70	71	90	112
4"	166	2 psi	166	191	246	309	73	73	92	114
		5 psi	251	298	382	483	112	114	144	179

PORT SIZE INCHES	CV	PRESSURE DROP ACROSS VALVE	R134A				R507			
			EVAPORATING TEMPERATURE				EVAPORATING TEMPERATURE			
			-20°F	0°F	+20°F	+40°F	-20°F	0°F	+20°F	+40°F
¾"	6.4	2 psi	1.5	2.1	3.2	3.6	1.9	2.5	3.3	4.2
		5 psi	2.1	3.1	4.8	5.5	2.8	4.0	5.1	6.6
1"	11.7	2 psi	2.8	3.8	5.8	6.6	3.0	5.0	6.0	7.7
		5 psi	3.9	5.6	8.3	10	5.0	7.0	9.3	12
1¼"	16.4	2 psi	3.9	5.4	8.1	9.2	5.0	6.0	8.4	11
		5 psi	5.5	7.3	12	14	7.0	10	13	17
1½"	35	2 psi	8.3	11	17	20	10	14	18	23
		5 psi	12	17	26	30	16	21	28	36
2"	47	2 psi	11	15	23	26	14	18	24	31
		5 psi	16	23	36	41	21	28	37	48
2½"	77	2 psi	18	25	38	43	23	30	39	51
		5 psi	26	37	58	67	34	46	61	79
3"	104	2 psi	25	34	52	59	31	41	53	68
		5 psi	35	50	73	80	46	63	82	106
4"	166	2 psi	39	54	82	93	49	65	85	109
		5 psi	55	80	126	144	74	100	132	170

Conditions: Capacities based on evaporator temperatures shown and 86°F liquid. R717: For each 10°F lower liquid temperature, increase above table capacity by 3%. R22, R134a, R507: For each 10°F lower liquid temperature, increase above table capacity by 5%.

For liquid overfeed evaporator suction between normal 2:1 to 5:1 rate, add 20% to the evaporator load or use the next larger port size to accommodate liquid volume accompanying the suction gas and to reduce impact velocities.

† -20°F capacities are based on a two stage system. For suction stop valves at temperatures below 0°F, alternate low pressure drop valves are preferably used such as Hansen Two-Step Gas-Powered Suction Stop Valve Type HCK5D or Gas-Powered Solenoid Valve Type HS9B.

## HIGH PRESSURE LIQUID VALVE CAPACITIES - KILOWATTS

PORT SIZE MM	R717		R22		R134A		R507	
	Pressure Drop (ΔP) BAR		Pressure Drop (ΔP) BAR		Pressure Drop (ΔP) BAR		Pressure Drop (ΔP) BAR	
	.15	.3	.15	.3	.15	.3	.15	.3
20	452	630	127	151	100	141	64	90
25	822	1162	195	275	181	256	116	163
32	1151	1627	272	385	254	359	162	229
40	2466	3487	584	825	544	769	347	490
50	3287	4649	778	1101	725	1025	462	654
65	5424	7671	1284	1816	1196	1691	763	1079
80	7314	10,344	1732	2449	1612	2280	1029	1455
100	11,670	16,500	2763	3907	2573	3638	1642	2321

Note: Ammonia capacities are based on 30°C liquid temperature, -5°C evaporator temperature, and no flashing through the valve. Halocarbon capacities are based on 35°C saturated liquid temperatures and -5°C evaporator temperature.

## PUMPED LIQUID VALVE CAPACITIES - KILOWATTS - 1:1 RECIRCULATION

PORT SIZE MM	R717		R22		R134A		R507	
	Pressure Drop (ΔP) BAR		Pressure Drop (ΔP) BAR		Pressure Drop (ΔP) BAR		Pressure Drop (ΔP) BAR	
	.15	.3	.15	.3	.15	.3	.15	.3
20	621	879	145	205	141	199	103	146
25	1130	1598	263	372	256	362	187	265
32	1582	2237	369	521	359	507	262	371
40	3389	4793	790	1117	769	1087	562	795
50	4519	6391	1053	1490	1025	1449	750	1061
65	7457	10,546	1738	2458	1691	2391	1237	1750
80	10,055	14,221	2344	3315	2280	3225	1669	2360
100	16,044	22,689	3740	5289	3638	5145	2662	3765

Note: Pumped liquid line capacities are based on -10°C liquid temperature and -10°C evaporator temperature. For evaporator temperatures between -40°C and 10°C, capacities are within 5% for ammonia and ±10% for halocarbon refrigerants.

### Sizing Valve Based on Recirculation Rate

Table is for 1:1 recirculation rate. For higher recirculation rates, multiply required capacity by the recirculation rate and select port size from table. (ie. for a 100 kW ammonia evaporator coil and 4:1 recirculation rate, multiply 4x100=400 kW and select closest port size; 3/4" (20mm) port with 2 psid (.15 bar) pressure drop)

## HOT GAS DEFROST NOMINAL VALVE SIZING CAPACITIES - KILOWATTS

(Defrosting Evaporator Size Kilowatts)

APPLICATION	REFRIGERANT	PORT SIZE (MM)					
		20	25	32	40	50	65
Hot Gas Solenoid*	R717	32-53	53-99	99-137	137-257	257-373	373-580
	R22, R134a, R507	21-28	28-53	53-70	70-113	113-165	165-264

\* Or an outlet pressure regulator with electric shut-off (HA4AOS).

Evaporator kW at 5°C TD (temperature differential), valve capacities are conservative. These capacities can be modified up or down depending on type of evaporator, temperature, mass, frost thickness, defrosting time, etc. Typical for -25°C evaporator.



## SUCTION VAPOR CAPACITIES - KILOWATTS

(1 Ton = 12,000 Btu/hr = 3.517kW = 3024 kcal/hr)

PORT SIZE MM	Kv	PRESSURE DROP ACROSS VALVE	R717				R22			
			EVAPORATING TEMPERATURE				EVAPORATING TEMPERATURE			
			-25°C†	-15°C	-5°C	5°C	-25°C	-15°C	-5°C	5°C
20	5.5	.15 bar	27	30	37	45	9.0	11	14	17
		.30 bar	36	41	51	63	12	16	20	24
25	10	.15 bar	49	54	67	82	17	21	26	31
		.30 bar	66	74	93	115	23	29	36	44
32	14	.15 bar	68	76	94	115	23	29	36	44
		.30 bar	92	104	131	161	32	40	50	61
40	30	.15 bar	146	162	202	247	50	63	77	94
		.30 bar	197	223	280	345	68	87	108	132
50	40	.15 bar	195	216	270	330	66	84	103	126
		.30 bar	263	297	374	460	91	115	144	176
65	66	.15 bar	322	357	445	544	110	138	170	207
		.30 bar	434	490	617	759	150	190	237	290
80	89	.15 bar	435	481	600	734	148	186	230	280
		.30 bar	586	661	832	1024	202	257	319	391
100	142	.15 bar	693	768	957	1171	236	297	366	446
		.30 bar	934	1054	1327	1634	322	410	510	624

PORT SIZE MM	Kv	PRESSURE DROP ACROSS VALVE	R134A				R507			
			EVAPORATING TEMPERATURE				EVAPORATING TEMPERATURE			
			-25°C	-15°C	-5°C	5°C	-25°C	-15°C	-5°C	5°C
20	5.5	.15 bar	8.2	11	14	18	8.0	10	13	16
		.30 bar	11	15	19	24	11	14	18	22
25	10	.15 bar	11	14	18	23	14	18	23	29
		.30 bar	14	19	25	31	19	25	32	40
32	14	.15 bar	16	22	28	35	20	25	32	40
		.30 bar	22	29	38	49	27	35	45	57
40	30	.15 bar	35	47	60	75	42	54	69	86
		.30 bar	47	63	82	105	58	74	96	121
50	40	.15 bar	47	62	80	101	56	71	91	115
		.30 bar	62	84	110	139	77	99	128	162
65	66	.15 bar	78	102	132	166	93	118	151	190
		.30 bar	102	139	181	230	128	163	211	267
80	89	.15 bar	105	138	177	224	125	159	204	257
		.30 bar	158	187	244	310	172	220	284	359
100	142	.15 bar	167	220	283	357	199	253	325	409
		.30 bar	220	298	389	495	274	352	453	573

Conditions: Capacities based on evaporator temperatures shown and 30°C liquid. R717: For each 5°C lower liquid temperature, increase above table capacity by 3%. R22, R134a, R507: For each 5°C lower liquid temperature, increase above table capacity by 5%.

For liquid overfeed evaporator suction between normal 2:1 to 5:1 rate, add 20% to the evaporator load or use the next larger port size to accommodate liquid volume accompanying the suction gas and to reduce impact velocities.

† -25°C capacities are based on a two stage system. For suction stop valves at temperatures below -15°C, alternate low pressure drop valves are preferably used such as Hansen Two-Step Gas-Powered Suction Stop Valve Type HCK5D or Gas-Powered Solenoid Valve Type HS9B.

## INSTALLATION DIMENSIONS 3/4" THRU 4" HS4D/HS4DW

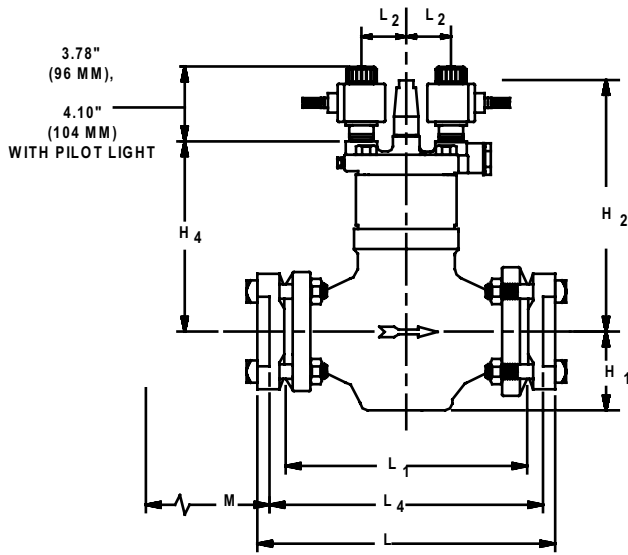

**HS4D FLANGED VALVE**

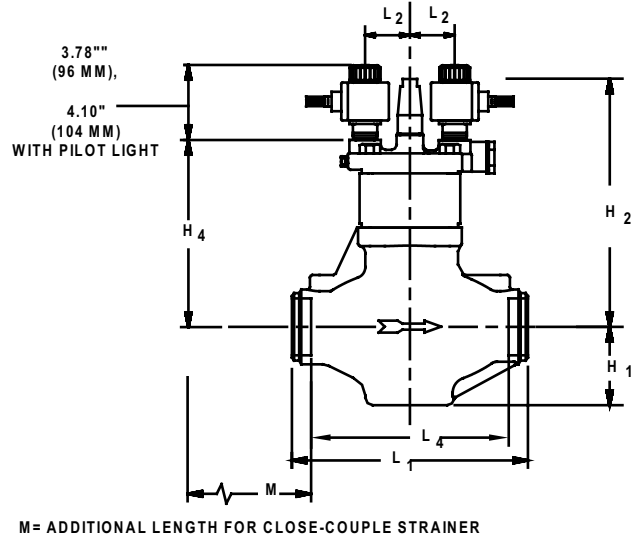

**HS4DW WELD-IN VALVE**

M = ADDITIONAL LENGTH FOR CLOSE-COUPLE STRAINER

### INSTALLATION DIMENSIONS, HS4D FLANGED VALVE INCHES (MM)

PORT SIZE (MM)	H <sub>1</sub>	H <sub>2</sub>	H <sub>4</sub>	L		L <sub>1</sub>	L <sub>2</sub>	L <sub>4</sub>	M	W*
				FPT,SW	WN,ODS					
3/4", 1", 1 1/4" (20, 25, 32)	3.09 (78)	8.45 (215)	6.31 (160)	8.20 (208)	8.94 (227)	6.19 (157)	2.38 (60)	7.20 (183)	3.70 (94)	4.50 (114)
1 1/2", 2" (40, 50)	2.87 (73)	11.0 (279)	7.88 (200)	12.39 (315)	13.39 (340)	9.88 (251)	2.35 (60)	10.89 (277)	9.83 (250)	4.50 (114)
2 1/2" (65)	3.62 (92)	12.45 (316)	9.29 (236)	13.01 (330)	14.03 (356)	9.88 (251)	2.35 (60)	11.01 (280)	9.83 (250)	5.62 (143)
3" (80)	4.06 (103)	12.76 (324)	9.64 (245)	15.38 (391)	16.40 (417)	12.25 (311)	2.35 (60)	13.38 (340)	12.20 (310)	6.50 (165)
4" (100)	4.69 (119)	13.65 (347)	10.55 (268)	17.01 (432)	20.51 (521)	14.12 (359)	2.69 (68)	15.01 (381)	14.07 (357)	8.06 (205)

\*Maximum width of valve. M = additional length for close-coupled strainer

### INSTALLATION DIMENSIONS, HS4DW WELD-IN VALVE INCHES (MM)

PORT SIZE (MM)	H <sub>1</sub>	H <sub>2</sub>	H <sub>4</sub>	L <sub>1</sub>	L <sub>2</sub>	L <sub>4</sub>	M	W*
3/4", 1", 1 1/4" (20, 25, 32)	3.07 (78)	8.45 (215)	6.31 (160)	10.44 (265)	2.38 (60)	9.00 (229)	10.44 (265)	3.56 (90)
1 1/2", 2" (40, 50)	2.87 (73)	11.0 (279)	7.88 (200)	10.38 (264)	2.35 (60)	8.94 (227)	10.38 (264)	4.64 (118)
2 1/2" (65)	3.62 (92)	12.45 (316)	9.29 (236)	11.38 (289)	2.35 (60)	9.38 (238)	11.38 (289)	5.62 (143)
3" (80)	4.06 (103)	12.76 (324)	9.64 (245)	12.25 (311)	2.35 (60)	—	12.25 (311)	6.50 (165)
4" (100)	4.69 (119)	13.65 (347)	10.55 (268)	14.12 (359)	2.69 (68)	—	14.12 (359)	8.06 (205)

\*Maximum width of valve. M = additional length for close-coupled strainer

## SERVICE AND MAINTENANCE

**Failure to Open:** Wrong voltage coil; low line voltage; controlling switch or thermostat not contacting; coil is burned-out; adjacent shut-off valve closed; plunger or main valve seat is dirt jammed; adapter gasket holes not aligned with holes in body and adapter; dirt packed under teflon seal rings enabling excessive blow-by; dirt blocking internal passages.

**Failure to Close:** controlling switch or thermostat not opening contacts; manual opening stem is turned in; valve installed in wrong direction; damage or dirt at main valve seat or one of the pilot seats; main piston bleed hole plugged.

**Before opening valve or disassembling pilot(s) for service, be sure its isolated from the system and all refrigerant is removed (pumped out to zero pressure).**

Follow usual refrigeration system safe servicing procedure. Read CAUTION section of this bulletin before attempting to service; see page 16.

To check a solenoid pilot section of valve, disconnect electrical power from coil. Remove the coil by unscrewing the coil knob. Slowly loosen, then remove the four solenoid tube screws, solenoid tube and plunger from valve. Inspect for dirt and damage to teflon seat and stainless steel pilot orifice. Plunger should move smoothly in solenoid tube. If plunger is damaged or "peened" over on the end, or makes excessive "buzzing" noise, replace plunger and solenoid tube as a set. Clean, polish or replace parts as necessary. Lightly oil solenoid tube gasket, reassemble pilot section of valve and replace coil knob.

### 3/4" thru 1 1/4" (20 thru 32 mm)

Use a 3/8" (9 mm) male hexagon wrench to loosen the four adapter bolts. Carefully break gasket seals before removing bolts; proceed slowly to avoid any refrigerant which may still remain in the valve. Remove piston housing and inspect. If any of the upper piston parts are stuck, inspect disc and piston bore for burrs, nicks or other damage. Inspect the remainder of the valve, including the main piston. If main piston parts are stuck, remove the 2" hex bottom cap to facilitate separation of the valve V-port/seat from the disc piston (flanged valve only). Inspect disc and piston bore for burrs, nicks and other damage. Remove burrs and nicks, clean or replace disc pistons as necessary. Long-life seals on disc pistons need only be replaced when damaged or severely worn. Inspect V-port/seat and main valve seat for nicks, marks, etc. Main valve seat may be lapped by hand or power drill to remove marks. Clean, polish or replace parts as necessary. If necessary, the V-port tapered seat may be reconditioned by removing up to 0.04" (1 mm) of teflon from it on a lathe. Lightly lubricate all parts and gaskets with soft rag containing refrigerant oil. Align holes in valve body, adapter gaskets, piston housing, and adapter to assure proper operation. Re-assemble valve. Carefully check entire valve for leaks before restoring it to service.

### 1 1/2" thru 4" (40 thru 100 mm)

Loosen adapter bolts using a 12" adjustable wrench. Carefully break gasket seals before removing bolts; proceed slowly to avoid any refrigerant which may still remain in the valve. Remove upper piston housing and inspect. If any of the upper piston parts are stuck, inspect disc and upper piston bore for burrs, nicks or other damage. Inspect the remainder of the valve, including the main piston. If disc piston is difficult to remove, insert a 1/4"-20 threaded screw into center of piston and lift straight-up. Inspect piston and piston bore for burrs, nicks and other damage. Remove burrs and nicks, clean or replace piston as necessary. Long-life seals on disc piston need only be replaced when damaged or severely worn. These valves have a removable stainless steel main valve seat. To remove seat ring for inspection, first remove small hex head seat screw. Turn seat ring counter-clockwise by turning it out with wrench and a steel bar tool positioned horizontally or by carefully tapping seat ring notch with a punch and hammer. Inspect V-port/seat and main valve seat for nicks, marks, etc. Main valve seat may be lapped by hand or power drill to remove marks. Grease and replace seat seal O-ring. Clean, polish or replace parts as necessary. The V-port tapered seat may be reconditioned by removing up to 0.04" (1 mm) of teflon from it on a lathe. Lightly lubricate all parts and gaskets with soft rag containing refrigerant oil. Align hole in valve body, adapter gaskets, piston housing, and adapter to assure proper operation. Reassemble valve. Carefully check entire valve for leaks before restoring it to service.

## MANUAL OPENING

The stem is located on top of adapter cover. Slowly remove manual opening stem seal cap, being cautious to avoid any refrigerant which may have collected under it. Turn stem in (clockwise) to open valve manually; this will open valve to 10% capacity position. Turn stem out, counter-clockwise to return valve to automatic operation.

**PARTS LIST 3/4" THRU 1 1/4"**  
(20 mm thru 32 mm)

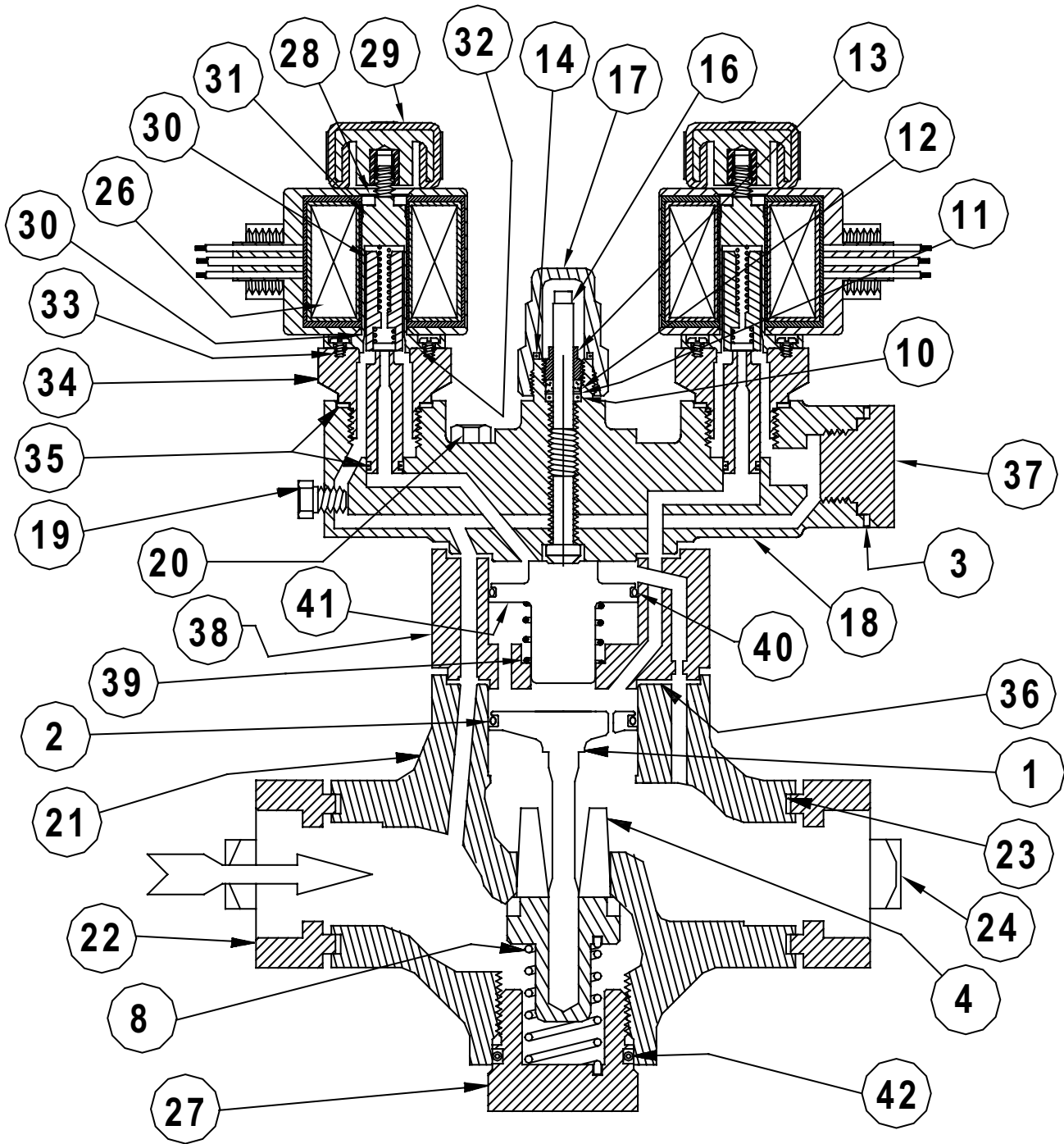

FLANGED VALVE SHOWN. WELD IN LINE PARTS LIST IS THE SAME.

**PARTS LIST ¾" THRU 1¼"**  
(20 mm thru 32 mm)

ITEM	DESCRIPTION	QTY	PART NO.
	<b>Main Piston Kit</b>	<b>1</b>	<b>75-1019</b>
	<i>Above kits consist of:</i>		
1	Main Piston	1	75-0191
2	Piston Seal	1	75-0353
36	Adapter Gasket	2	75-0489
23	Flange Gasket	2	70-0132
	<b>Upper Piston Kit ¾" - 1-1/4"</b>	<b>1</b>	<b>70-1109</b>
	<i>Above kits consist of:</i>		
41	Upper Piston	1	75-2515
40	Piston Seal	1	75-0353
39	Upper Spring	1	75-2538
36	Adapter Gasket	2	75-0489
	<b>V-Port/Seat Kit ¾"</b>	<b>1</b>	<b>75-1020</b>
	<b>V-Port/Seat Kit 1"</b>	<b>1</b>	<b>75-1021</b>
	<b>V-Port/Seat Kit 1-1/4"</b>	<b>1</b>	<b>75-1022</b>
	<i>Above kits consist of:</i>		
4a	¾" V-Port/Seat	1	75-0194
4b	1" V-Port/Seat	1	75-0193
4c	1-1/4" V-Port/Seat	1	75-0192
8	Closing Spring	4	75-0287
42	Bottom Cap O-Ring (Flanged Valve)	1	75-0183
	Seat Ring O-Ring (Weld-in Valve not shown)	1	75-2433
	<b>Gasket Kit</b>	<b>1</b>	<b>75-1023</b>
	<i>Above kit consists of:</i>		
36	Cover Gasket	1	75-0489
42	Bottom Cap O-Ring (Flanged Valve)	1	75-0183
	Seat Ring O-Ring (Weld-in Valve not shown)	1	75-2433
10	Stem O-Ring	1	70-0010
11	Stem Washer	1	70-0026
12	Stem Packing	1	70-0025
13	Packing Nut	1	70-0019
14	Seal Cap O-Ring	2	70-0011
23	Flange Gasket	1	70-0132
32	Solenoid Tube Gasket	1	70-0301
35	Port Plug Gasket & O-Ring	1	75-1071
38	Upper Piston Housing ¾" - 1-1/4"	1	75-2516
16	<b>Manual Opening Stem</b>	<b>1</b>	<b>75-0164</b>
17	<b>Seal Cap</b>	<b>1</b>	<b>50-0411</b>
19	<b>Gauge Port Plug (1/4" NPT)</b>	<b>1</b>	<b>75-0189</b>
18	<b>Adapter</b>	<b>1</b>	<b>75-2516</b>
20	<b>Adapter Bolts, Socket Cap</b>	<b>4</b>	<b>75-2537</b>
27	<b>Bottom Cap (Flanged Valve)</b>	<b>1</b>	<b>75-0155</b>
	<b>Seat Ring (Weld-in Valve not shown)</b>	<b>1</b>	<b>75-2402</b>
21a	<b>Body ¾", 1"</b>	<b>1</b>	<b>Factory</b>
21b	<b>Body 1-1/4", 2 Bolt</b>	<b>1</b>	<b>Factory</b>
22	<b>Flange (Various)</b>	<b>2</b>	<b>Factory</b>
24	<b>Flange Bolt (5/8" - 11x2.75)</b>	<b>4</b>	<b>70-0339</b>
25	<b>Flange Nut (5/8" - 11)</b>	<b>4</b>	<b>70-0136</b>
	<b>Coil Kit (115V) 1/2" Fitting w/leads</b>	<b>1</b>	<b>70-1085</b>
	<b>Coil Kit (208/230V) 1/2" Fitting w/leads</b>	<b>1</b>	<b>70-1086</b>
	<b>Coil Kit (24V) 1/2" Fitting w/leads</b>	<b>1</b>	<b>70-1087</b>
	<b>Coil Kit (Other Voltages)</b>	<b>1</b>	<b>Factory</b>
	<i>Above kits consist of:</i>		
26a	Bare Coil, 115V 50/60 Hz w/leads	1	70-0580
26b	Bare Coil, 208/230V 50/60 Hz w/leads	1	70-0581
26c	Bare Coil, 24V 50/60 Hz w/leads	1	70-0582
26d	Other Voltage Coils	1	Factory
29	Coil Knob	1	70-0579
	<b>Solenoid Tube/Plunger Kit</b>	<b>1</b>	<b>70-1059</b>
	<i>Above kits consist of:</i>		
29	Coil Knob	1	70-0579
30	Plunger	1	70-0295
31	Solenoid Tube	1	70-0298
32	Solenoid Tube Gasket	1	70-0301
33	Tube Screws	4	70-0297
34	<b>Solenoid Control Module</b>	<b>1</b>	<b>70-1052</b>
	(Control Module Body, including Plunger Kit, Port Plug Gasket and O-Ring (less coil))		

**PARTS LIST 1½" THRU 4"**  
**(40 mm thru 100 MM)**

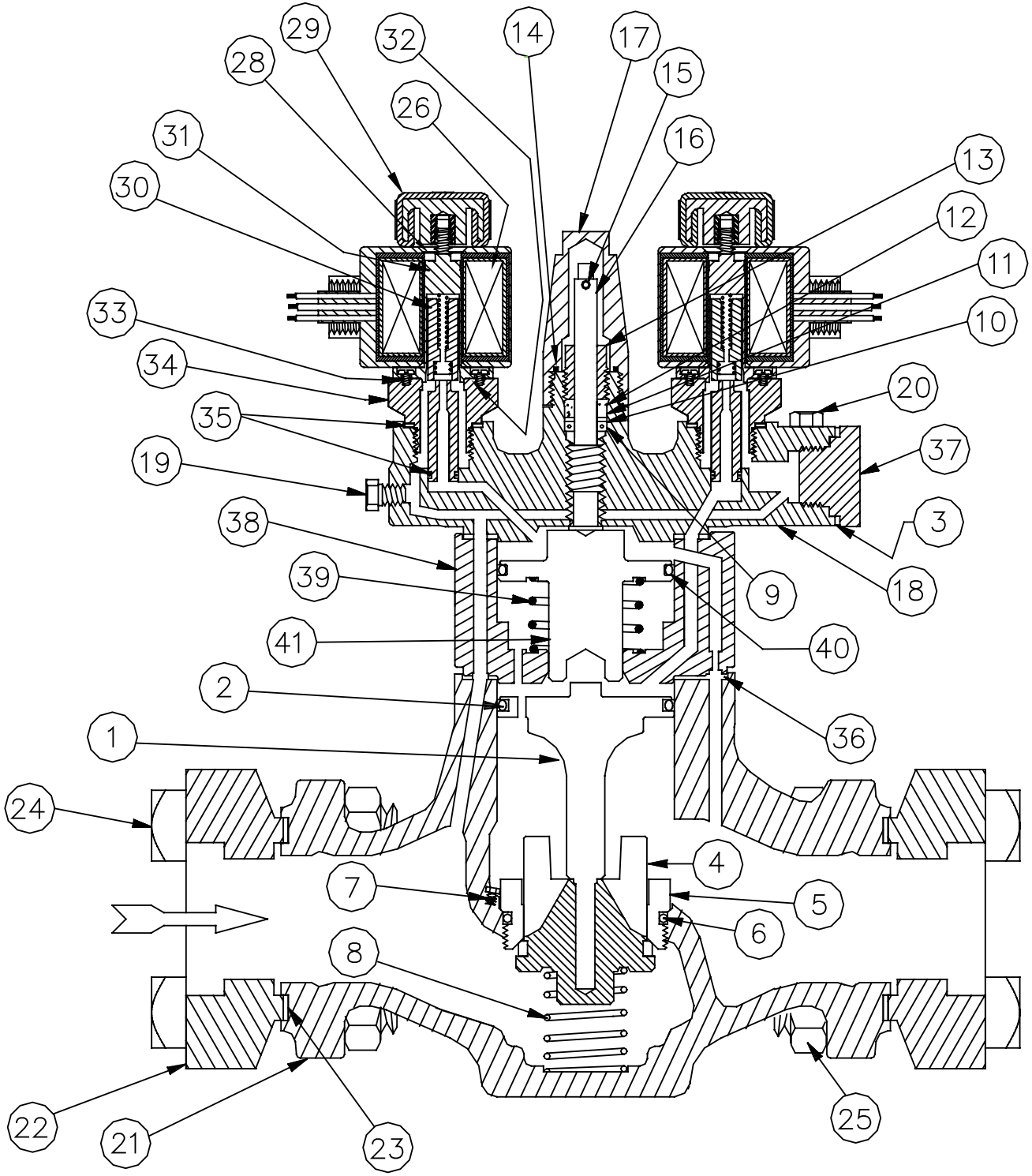

**FLANGED VALVE SHOWN. WELD IN LINE PARTS LIST IS THE SAME.**

**PARTS LIST 1½" THRU 4"**  
(40 mm thru 100 mm)

ITEM	DESCRIPTION	QTY	PART NO.
	<b>Main Piston Kit 1-1/2", 2"</b>	1	<b>75-1025</b>
	<b>Main Piston Kit 2-1/2"</b>	1	<b>75-1026</b>
	<b>Main Piston Kit 3"</b>	1	<b>75-1027</b>
	<b>Main Piston Kit 4"</b>	1	<b>75-1028</b>
	<i>Above kits consist of:</i>		
1a	Main Piston 1-1/2", 2"	1	75-0957
1b	Main Piston 2-1/2"	1	75-0169
1c	Main Piston 3"	1	75-0159
1d	Main Piston 4"	1	75-0278
2a	Piston Seal 1-1/2", 2"	2	75-0292
2b	Piston Seal 2-1/2", 3"	2	75-0293
2c	Piston Seal 4"	2	75-0236
36a	Adapter Gasket 1-1/2", 2"	2	75-0113
36b	Adapter Gasket 2-1/2", 3"	2	75-0093
36c	Adapter Gasket 4"	2	75-0233
23a	Flange Gasket 1-1/2", 2"	2	75-0138
23b	Flange Gasket 2-1/2", 3"	2	75-0125
23c	Flange Gasket 3"	2	75-0137
23d	Flange Gasket 4"	2	75-0253
	<b>Upper Piston Kit 1-1/2" - 2"</b>	1	<b>70-1110</b>
	<b>Upper Piston Kit 2-1/2" - 3"</b>	1	<b>70-1111</b>
	<b>Upper Piston Kit 4"</b>	1	<b>70-1112</b>
	<i>Above kits consist of:</i>		
41a	Upper Piston 1-1/2" - 2"	1	75-2511
41b	Upper Piston 2-1/2" - 3"	1	75-2528
41c	Upper Piston 4"	1	75-2543
40a	Piston Seal 1-1/2" - 2"	1	75-0292
40b	Piston Seal 2-1/2" - 3"	1	75-0293
40c	Piston Seal 4"	1	75-2541
39a	Upper Spring 1-1/2" - 2"	1	75-2532
39b	Upper Spring 2-1/2" - 3"	1	75-2541
39c	Upper Spring 4"	1	75-2548
36a	Adapter Gasket 1-1/2", 2"	2	75-0113
36b	Adapter Gasket 2-1/2", 3"	2	75-0093
36c	Adapter Gasket 4"	2	75-0233
	<b>V-Port/Seat Kit 1-1/2"</b>	1	<b>75-1029</b>
	<b>V-Port/Seat Kit 2</b>	1	<b>75-1030</b>
	<b>V-Port/Seat Kit 2-1/2"</b>	1	<b>75-1031</b>
	<b>V-Port/Seat Kit 3"</b>	1	<b>75-1032</b>
	<b>V-Port/Seat Kit 4"</b>	1	<b>75-1033</b>
	<i>Above kits consist of:</i>		
4a	V-Port/Seat 1-1/2"	1	75-0369
4b	V-Port/Seat 2"	1	75-0177
4c	V-Port/Seat 2-1/2"	1	75-0178
4d	V-Port/Seat 3"	1	75-0179
4e	V-Port/Seat 4"	1	75-0313
36a	Adapter Gasket 1-1/2", 2"	2	75-0113
36b	Adapter Gasket 2-1/2", 3"	2	75-0093
36c	Adapter Gasket 4"	2	75-0233
6a	Seat Seal O-Ring 1-1/2", 2"	1	75-0274
6b	Seat Seal O-Ring 2-1/2"	1	75-0275
6c	Seat Seal O-Ring 3", 4"	1	75-0276
7	Seat Screw	1	75-0220
8a	Closing Spring 1-1/2", 2"	1	75-0171
8b	Closing Spring 2-1/2"	1	75-0201
8c	Closing Spring 3"	1	75-0248
8d	Closing Spring 4"	1	75-0235
	<b>Coil Kit (115V) 1/2" Fitting w/leads</b>	1	<b>70-1085</b>
	<b>Coil Kit (208/230V) 1/2" Fitting w/leads</b>	1	<b>70-1085</b>
	<b>Coil Kit (24V) 1/2" Fitting w/leads</b>	1	<b>70-1087</b>
	<b>Coil Kit (Other Voltages)</b>	1	<b>Factory</b>
	<i>Above kits consist of:</i>		
26a	Bare Coil, 115V 50/60 Hz w/leads	1	70-0580
26b	Bare Coil, 208/230V 50/60 Hz w/leads	1	70-0581
26c	Bare Coil, 24V 50/60 Hz w/leads	1	70-0582
26d	Other Voltage Coils	1	Factory
29	Coil Knob	1	70-0579
<b>34</b>	<b>Solenoid Tube/Plunger Kit</b>	1	<b>70-1059</b>
	<i>Above kit consists of:</i>		
29	Coil Knob	1	70-0579
30	Plunger	1	70-0295
31	Solenoid Tube	1	70-0298
32	Solenoid Tube Gasket	1	70-0301
33	Tube Screws	4	70-0297

ITEM	DESCRIPTION	QTY	PART NO.
<b>34</b>	<b>Solenoid Control Module</b> (Control Module Body, including Plunger Kit, Port Plug Gasket and O-Ring (less coil))	1	<b>70-1052</b>
	<b>Gasket Kit 1 1/2", 2"</b>	1	<b>75-1039</b>
	<b>Gasket Kit 2 1/2"</b>	1	<b>75-1040</b>
	<b>Gasket Kit 3"</b>	1	<b>75-1041</b>
	<b>Gasket Kit 4"</b>	1	<b>75-1042</b>
	<i>Above kits consist of:</i>		
36a	Adapter Gasket 1-1/2", 2"	2	75-0113
36b	Adapter Gasket 2-1/2", 3"	2	75-0093
36c	Adapter Gasket 4"	2	75-0233
6a	Seat Seal O-Ring 1-1/2", 2"	1	75-0274
6b	Seat Seal O-Ring 2-1/2"	1	75-0275
6c	Seat Seal O-Ring 3", 4"	1	75-0276
9a	Back-up Washer 1-1/2" - 3"	1	75-0245
9b	Back-up Washer 4"	1	50-0351
10a	Stem O-Ring 1-1/2" - 3"	1	50-0179
10b	Stem O-Ring 4"	1	50-0253
11a	Stem Washer 1-1/2" - 3"	1	50-0046
11b	Stem Washer 4"	1	50-0247
12a	Stem Packing 1-1/2" - 3"	1	50-0045
12b	Stem Packing 4"	1	50-0248
13a	Packing Nut 1-1/2" - 3"	1	50-0013
13b	Packing Nut 4"	1	50-0251
14a	Seal Cap O-Ring	1	50-0432
14b	Seal Cap Gasket	1	50-0270
15a	Stem Pin 1-1/2" - 3"	1	75-0173
15b	Stem Pin 4"	1	75-0434
23a	Flange Gasket 1-1/2", 2"	2	75-0138
23b	Flange Gasket 2-1/2"	2	75-0125
23c	Flange Gasket 3"	2	75-0137
23d	Flange Gasket 4"	2	75-0253
32	Solenoid Tube Gasket	1	70-0301
35/37	Port Plug Gasket & O-Ring	1	75-1071
<b>18a</b>	<b>Adapter 1-1/2", 2"</b>	1	<b>75-2513</b>
<b>18b</b>	<b>Adapter 2-1/2", 3"</b>	1	<b>75-2527</b>
<b>18c</b>	<b>Adapter 4"</b>	1	<b>75-2546</b>
<b>5a</b>	<b>Seat Ring 1-1/2", 2"</b>	1	<b>75-0084</b>
<b>5b</b>	<b>Seat Ring 2-1/2"</b>	1	<b>75-0170</b>
<b>5c</b>	<b>Seat Ring 3"</b>	1	<b>75-0071</b>
<b>5d</b>	<b>Seat Ring 4"</b>	1	<b>75-0231</b>
<b>16a</b>	<b>Manual Opening Stem 1-1/2" - 3"</b>	1	<b>75-0079</b>
<b>16b</b>	<b>Manual Opening Stem 4"</b>	1	<b>75-0427</b>
<b>17a</b>	<b>Seal Cap 1-1/2" - 3"</b>	1	<b>75-0139</b>
<b>17b</b>	<b>Seal Cap 4"</b>	1	<b>50-0260</b>
<b>38a</b>	<b>Adapter 1-1/2", 2"</b>	1	<b>75-2512</b>
<b>38b</b>	<b>Adapter 2-1/2", 3"</b>	1	<b>75-2529</b>
<b>38c</b>	<b>Adapter 4"</b>	1	<b>75-2544</b>
<b>19</b>	<b>Gauge Port Plug (1/4" NPT)</b>	1	<b>75-0189</b>
<b>20a</b>	<b>Adapter Bolts 1-1/2", 2"</b>	4	<b>75-2533</b>
<b>20b</b>	<b>Adapter Bolts 2-1/2", 3"</b>	4	<b>75-2549</b>
<b>20c</b>	<b>Adapter Bolts 4"</b>	4	<b>75-2586</b>
<b>21a</b>	<b>Body 1-1/2", 2"</b>	1	<b>Factory</b>
<b>21b</b>	<b>Body 2-1/2"</b>	1	<b>Factory</b>
<b>21c</b>	<b>Body 3"</b>	1	<b>Factory</b>
<b>21d</b>	<b>Body 4"</b>	1	<b>Factory</b>
<b>22</b>	<b>Flange (Various)</b>	2	<b>Factory</b>
<b>24a</b>	<b>Flange Bolt 1-1/2", 2" (5/8" - 11x3.25")</b>	8	<b>70-0135</b>
<b>24b</b>	<b>Flange Bolt 2-1/2", 3" (3/4" - 10x3.75")</b>	8	<b>75-0202</b>
<b>24c</b>	<b>Flange Bolt 4" (7/8"-9x4")</b>	8	<b>75-0279</b>
<b>25a</b>	<b>Flange Nut 1-1/2", 2" (5/8"-11)</b>	8	<b>70-0136</b>
<b>25b</b>	<b>Flange Nut 2-1/2", 3" (3/4"-10)</b>	8	<b>75-0210</b>
<b>25c</b>	<b>Flange Nut 4" (7/8"-9)</b>	8	<b>75-0280</b>

## ORDERING INFORMATION

FLANGE VALVE CONNECTION STYLE AND SIZES INCHES (MM)			
PORT SIZE	FPT,SW,WN		ODS
	STD	ALSO	STD
¾" (20)	¾"	1", 1¼"	7/8" (22), 1½" (28), 1¾" (35)
1" (25)	1"	1¼"	1½" (28), 1¾" (35)
1¼" (32)	1¼"		1¾" (35)
1½" (40)	1½"	2"	1¾" (42), 2½" (54)
2" (50)	2"		2½" (54)
2½" (65)	2½"	3"	2¾" (67)
3" (80)	3"	—	3½" (79)
4" (100)	4"	—	4½" (105)

WELD-IN VALVE CONNECTION STYLE AND SIZES INCHES (MM)		
PORT SIZE	SW	WN
¾" (20)	¾", 1", 1¼"	—
1" (25)	1", 1¼"	—
1¼" (32)	1¼"	—
1½" (40)	1½", 2"	—
2" (50)	2"	—
2½" (65)	2½"	—
3" (80)	—	3"
4" (100)	—	4"

## TO ORDER

Specify type, flanged or weld-in, connection type and size, and strainer if required. Specify voltage and color of optional Beacon Pilot Light if required. Unless otherwise specified, standard coil with ½" wire lead connection will be supplied. Plug-in DIN connector is optional.

## OPTIONAL STRAINERS

Generous capacity strainer is a separate, close-coupled, 60 mesh (233 micron rating) unit with optional 100 mesh (150 micron) available in ¾" to 2-1/2".

## OPTIONAL BEACON PILOT LIGHTS

Pilot Light Kit includes Beacon pilot light, knob and o-ring. A/C Coils Only.

BEACON PILOT LIGHT KITS	
Color	Part No.
Red	70-1100
Amber	70-1101
Green	70-1102



## TYPICAL SPECIFICATIONS

"Two step refrigerant solenoid valves shall provide for two automated valve positions, partial and full flow. Valves shall have encapsulated, watertight coils, Teflon seats, carbon steel or ductile iron bodies, spring closing pilot and main valve seats, and be suitable for a safe working pressure of 400 psig (28 bar), as manufactured by Hansen Technologies Corporation or approved equal."

## CAUTION

Hansen valves are only for refrigeration systems. These instructions must be completely read and understood before selecting, using or servicing Hansen valves. Only knowledgeable, trained refrigeration mechanics should install, operate, or service these valves. Stated temperature and pressure limits should not be exceeded. Bonnets, solenoid tubes, etc. should not be removed from valves unless system has been evacuated to zero pressure. Must also see Safety Precautions in current List Price Bulletin and Safety Precautions Sheet supplied with product.

## WARRANTY

All Hansen products, except electronics, are guaranteed against defective materials or workmanship for one year F.O.B. factory. Electronics/electrical are guaranteed against defective materials or workmanship for 90 days F.O.B. factory. No consequential damages or field labor is included.

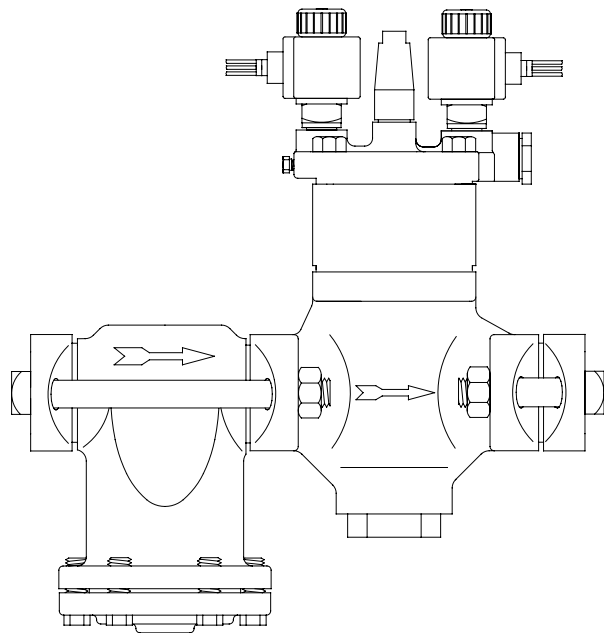

1-1/4" HS4D WITH CLOSE-COUPLED STRAINER

# HANSEN

Hansen Technologies Corporation  
 400 Quadrangle Dr, Suite F  
 Bolingbrook, Illinois 60440 USA  
 Tel: 630.325.1565 Fax: 630.325.1572 Toll: 800.426.7368  
 Email: info@hantech.com Web: www.hantech.com  
**USA · Asia · Europe · India · Latin America · Middle East**  
 © 2011 Hansen Technologies Corporation