

www.CRE-Marine.com  
Tel: + 44 01224 872 445  
Fax: + 44 01224 873 710  
Email: sales@CRE-Marine.com



# **‘B’ Class Expanded Beam Connector System Subsea / Underwater / Marine**



# 'B' Class Expanded Beam Connector System Subsea / Underwater / Marine

## Introduction:

CRE's range of metal shell Fibre Optic Fully Sealed Hermaphroditic Connectors focus on delivering high reliability in tough environments. The design offers a high integrity sealing arrangement, metal keyways, multiple options on size, along with our ability to design specific solutions for your application. They are designed for heavy duty use in the most rigorous underwater applications on the planet. Made of 316 stainless steel or custom built with any material specified, they come as standard with high open face pressure resistance. These robust and versatile connectors are rated to 4,000m in oil filled assemblies and up to 2,000m in moulded assemblies. They are designed for use for the heaviest power, signal and electro-mechanical applications.

## The most common applications:

- ROV
- Dive Bell Connectors
- Underwater Thruster

## Key Features:

- Multi size shell body
- 4 to 8 Channel Configurations
- Multimode 50/125 and 62.5/125 versions
- Singlemode 9/125 Fibre
- Available as Patchcords and Pigtailed Bulkheads
- Right angled Plug End also available
- Pressure up to 400 bar (Mated)
- Bulkhead open face pressure up to 400 bar
- Oil filled available as standard (OF)
- Tails with connections to suit ( ST/SC/ etc. )



### Options:

- Field Installable
- Bespoke design/configuration to suit customer requirements at no extra cost
- Available in alternative materials: Aluminium, Titanium etc.
- **Testing:**
  - Pressure testing up to 400 bar
  - Durability testing with 100 mate and re-mate cycles
  - Bulkhead open face pressure testing up to 400 bar

### Part Numbering System - Bulkhead Example

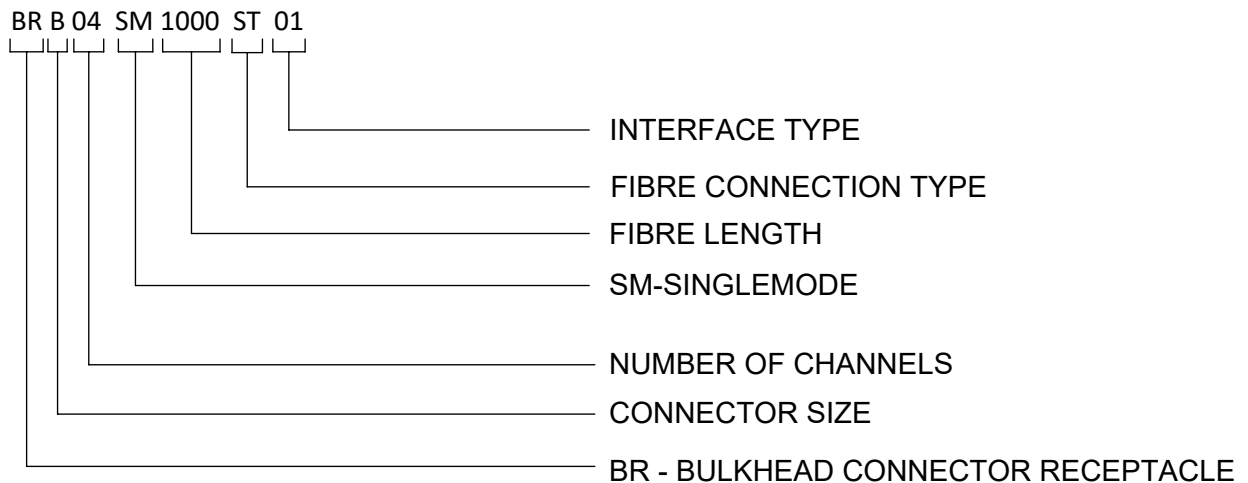

### Part Numbering System - Connector Example

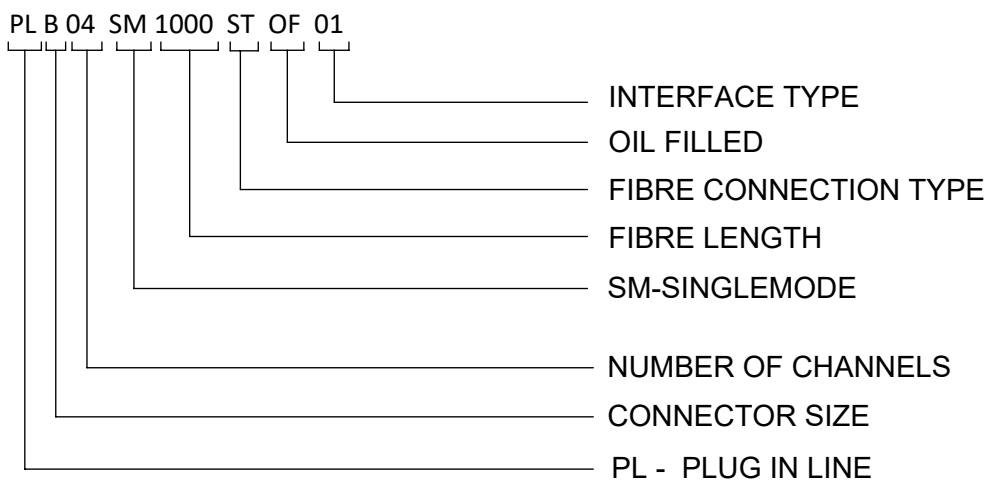



**Standard Mechanical Specification:**

COMPONENT	MATERIAL
Shell Body	Stainless Steel 316L
Retaining Nut	Stainless Steel/Aluminium Bronze
'O' Rings	Nitrile NI70

Contact CRE for special order materials.

**Electrical and Enviromental:**

- Singlemode Insertion Loss: 9/125 Fibre @ 1,310nm/1,550nm : Up To 2.0dB
- Multimode Insertion Loss: 50/125 & 62.5/125 @850nm/1300nm : Up To 1.0dB
- Operating Temperature: -40C to + 85C
- Storage Temperature: -55C to + 85C
- Durability: 2000 Matings minimum
- Depth Rating: 4000 Meters (2000m moulded assemblies)

**Fibre Characteristics:**

**Singlemode - 9/125 (SM)**

- Attenuation: 0.38dB/km @ 1,310nm
- Attenuation: 0.25dB/km @ 1,550nm
- Dispersion: 3.5ps/nm.km @ 1310nm
- Dispersion: 18.0ps/nm.km @ 1,550nm
- NA: 1.470

**Multimode - 50/125 (MM)**

- Attenuation: 2.8dB/km @ 850nm
- Attenuation: 0.8dB/km @ 1,300nm
- Bandwidth: 500MHz/km @ 850nm
- Bandwidth: 500MHz/km @1,300nm
- NA: 0.20
- 

**Multimode - 62.5/125 (MM)**

- Attenuation: 3.0dB/km @ 850nm
- Attenuation: 1.0dB/km @ 1,300nm
- Bandwidth: 200MHz/km @ 850nm
- Bandwidth: 500MHz/km @1,300nm
- NA: 0.27
-

# Reference Dimensions 'B' Fibre Connector

Bulkhead Connector Receptacle (BR)

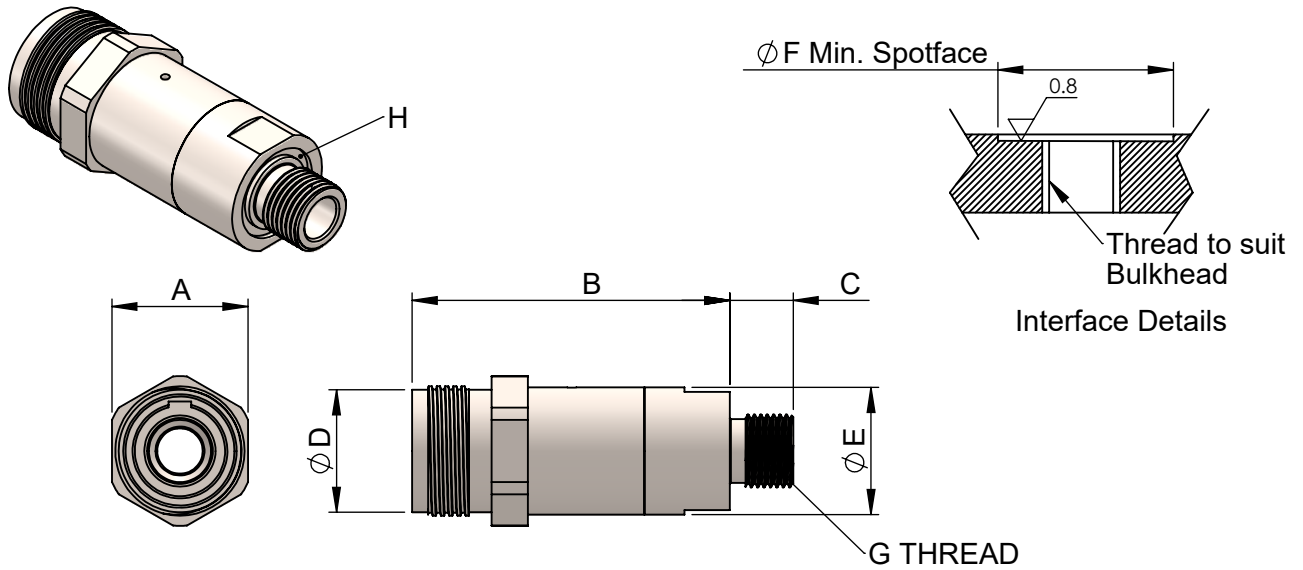

A	B	C	D	E	F	G	H-O'Ring	TYPE
30	70	14	27	28	30	7/16"- 20 UNF-2A	BS017	04
30	70	14	27	28	30	5/8"-18 UNF-2A	BS017	01
30	70	14	27	28	30	3/4"-16 UNF-2A	BS019	02
30	70	19	27	28	30	3/4"-16 UNF-2A	BS019	05
30	70	14	27	28	30	3/4"- 20 UNEF-2A	BS019	03

NOTE: For recommended Torque figures please refer to page 12

## Reference Dimensions 'B' Fibre Connector

Flanged Bulkhead Connector Receptacle (FR)

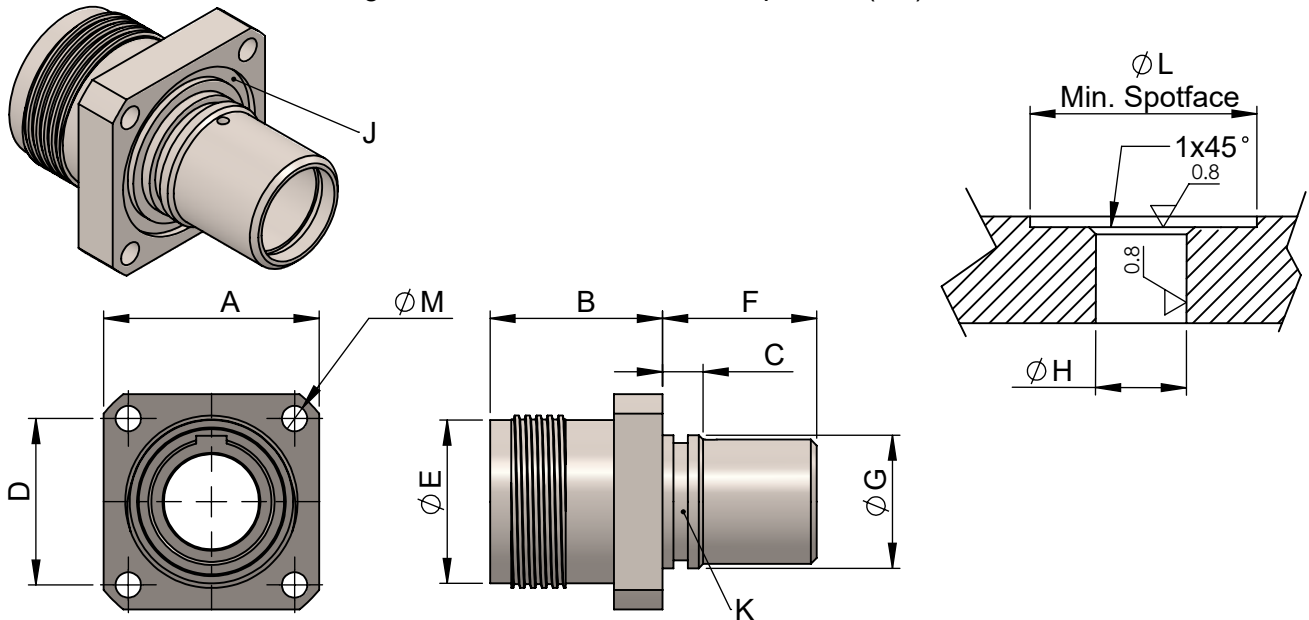

A	B	C	D	E	F	G	H	J-'O'Ring	K-'O' Ring	L	M	TYPE
35.6	28.5	6.75	27.5	27	25.5	22	22.05/22.1	BS022	BS018	50	4.25	03

Flanged Bulkhead Connector Receptacle-Composite (FR)

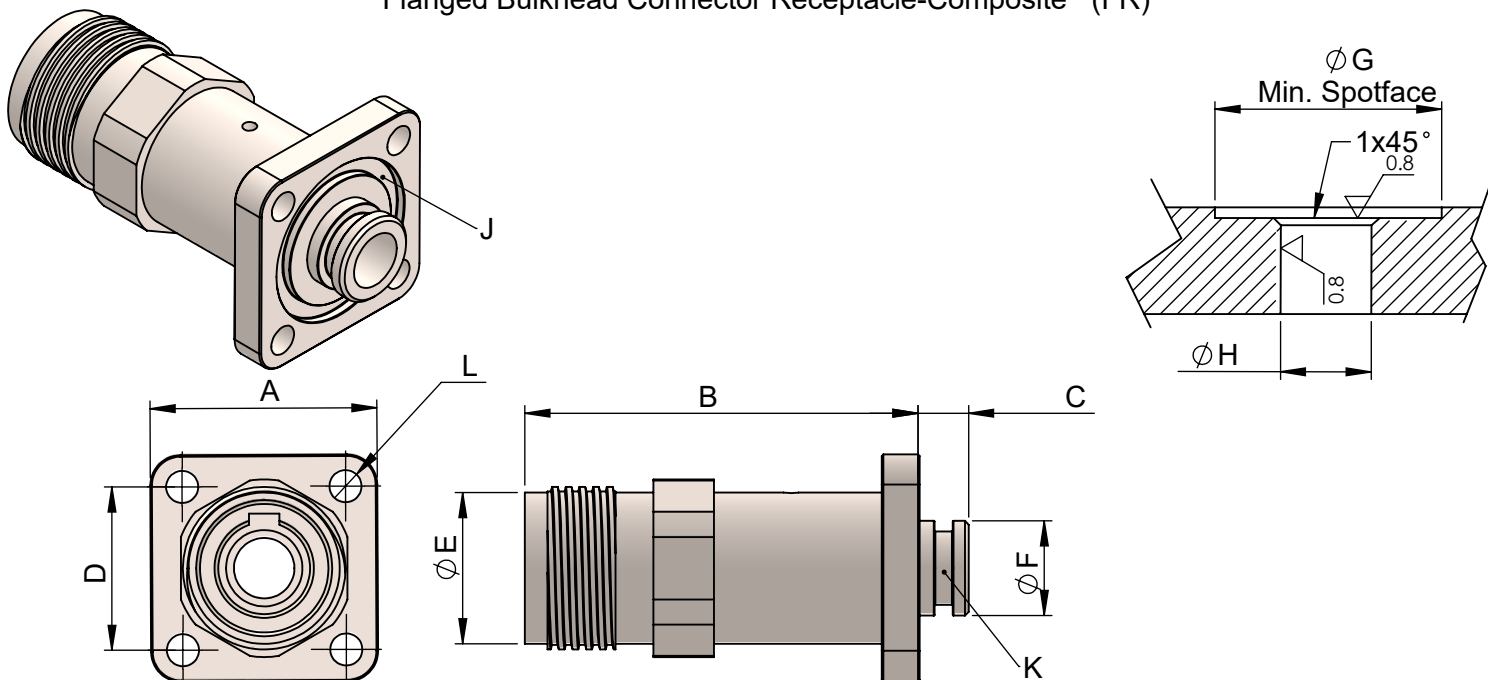

A	B	C	D	E	F	G	H	J-'O'Ring	K-'O'Ring	L	TYPE
38	70	14	25.4	27	15.8	52	15.85/15.9	BS116	N/A	5.6	02
38.1	70	9	25.4	27	24	52	24.05/24.1	BS022	BS019	4.25	04
45	70	12.5	31.8	27	18	60	18.05/18.1	BS118	BS016	7.0	01

# Reference Dimensions 'B' Fibre Connector

## Backshell Connector Receptacle (PL)

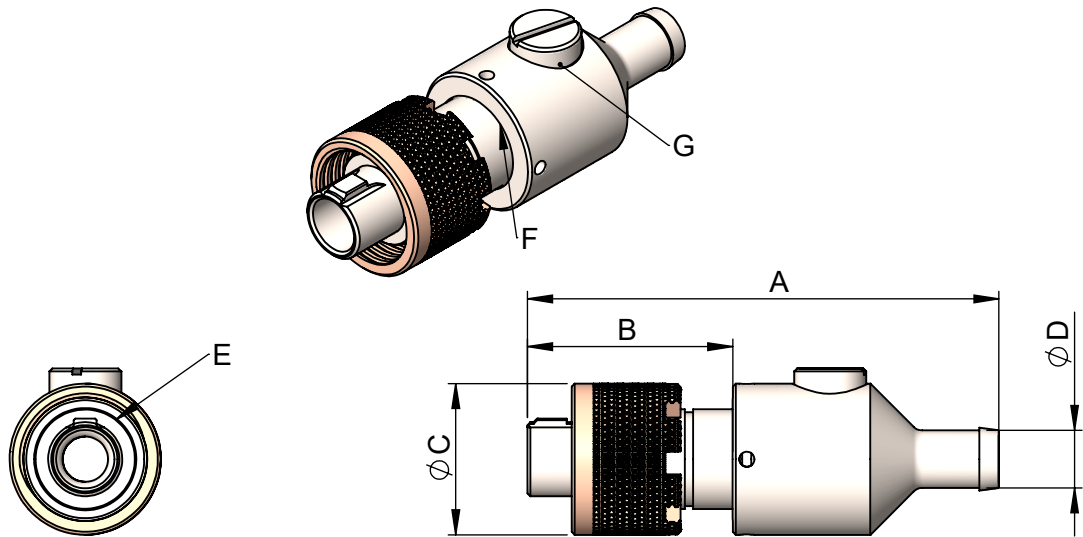

A	B	C	D	E-O'Ring	F-O'Ring	G-O'Ring	TYPE
87.25	35.25	31.7	12.5	21 x 1.65	6 x 1.5	22 x 2	01
92.25	35.25	31.7	19.5	21 x 1.65	6 x 1.5	22 x 2	02

## Backshell Connector Receptacle (PR)

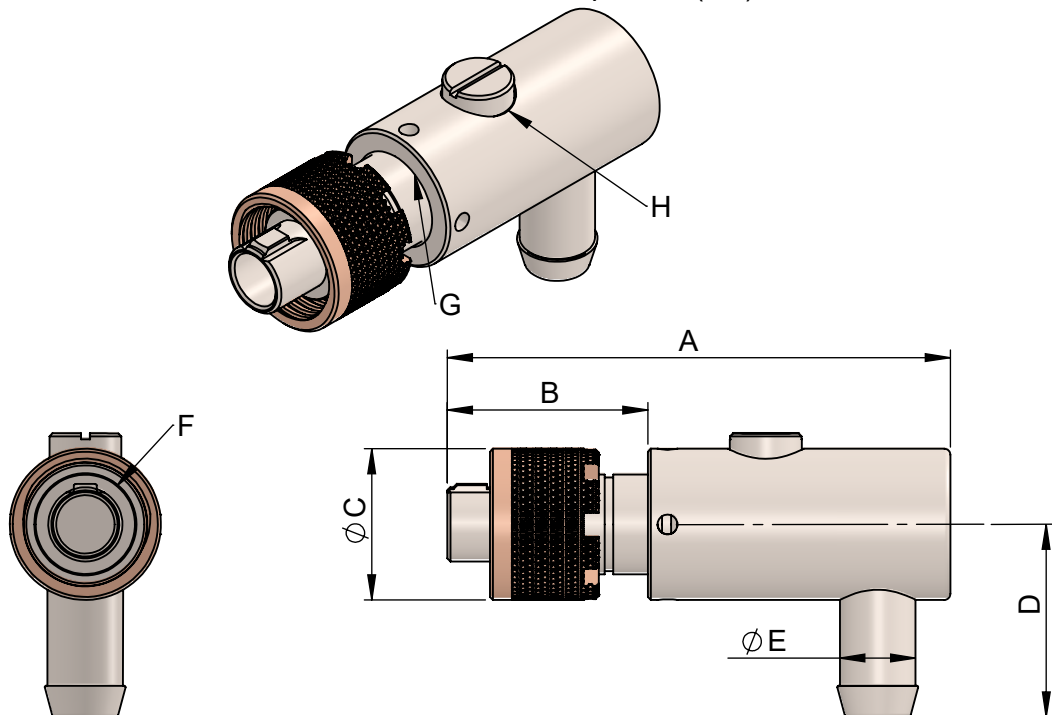

A	B	C	D	E	F-O'Ring	G-O'Ring	H-O'Ring	TYPE
93.25	35.25	31.7	36.5	15	21 x 1.65	22 x 2	6 x 1.5	01
93.25	35.25	31.7	36	19.5	21 x 1.65	22 x 2	6 x 1.5	02

## Reference Dimensions 'B' Fibre Connector

### Bulkhead Blanking Plug - PLBBC

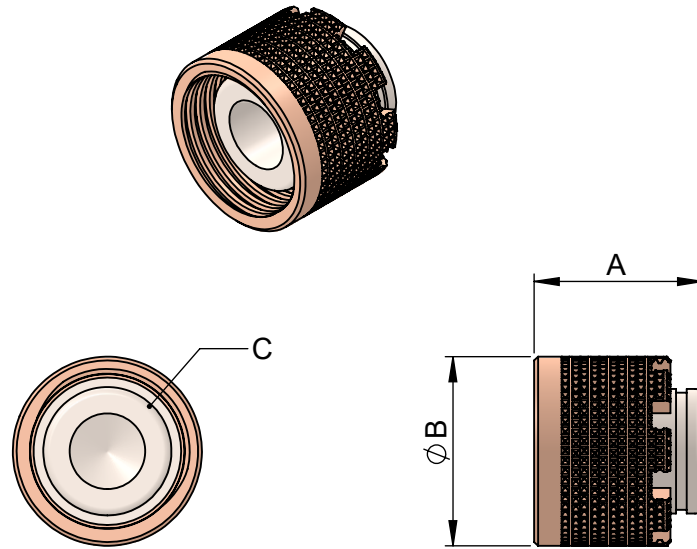

A	B	C-'O'Ring
21.8	31.7	21 x 1.65

### Cable Connector Blanking Plug - BRBBC

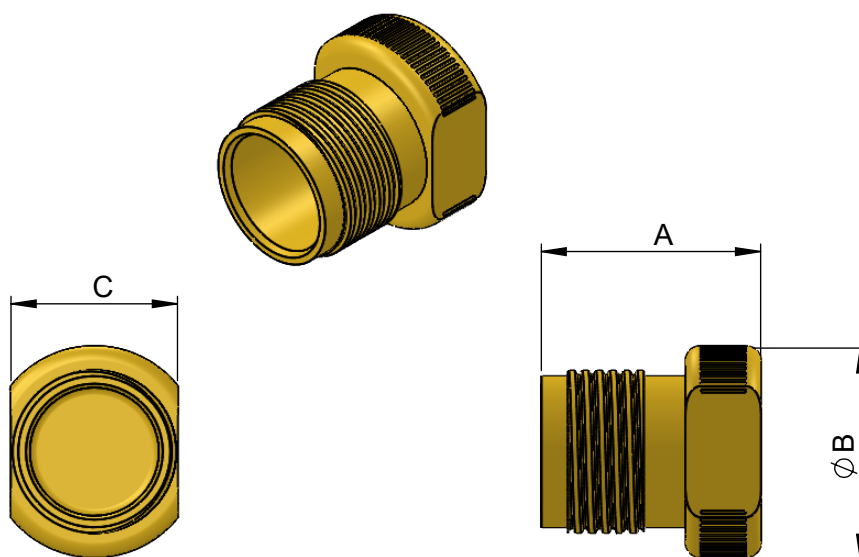

A	B	C
29	36	30

# Reference Dimensions 'B' Fibre Connector

Backshell Connector Receptacle - Straight / 90° Moulded

PLB

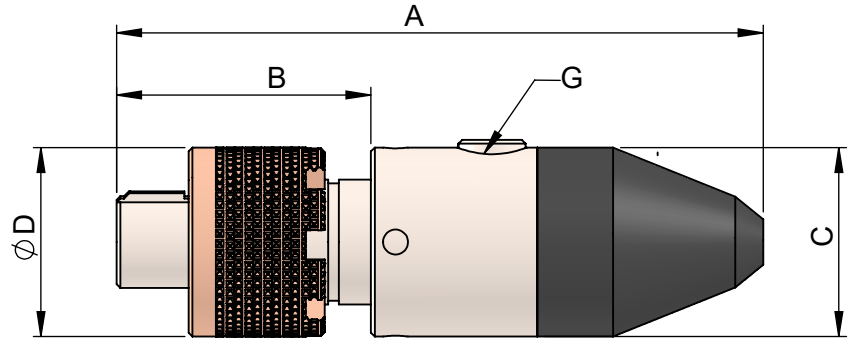
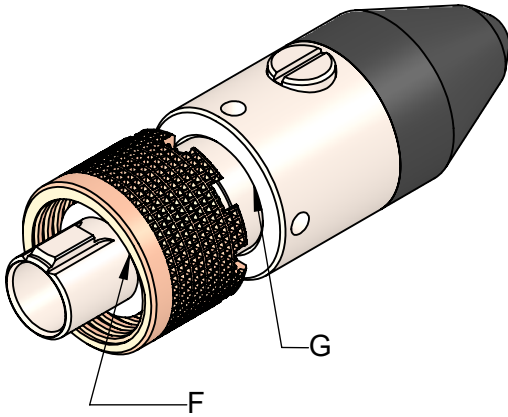

A	B	C	D	F-'O'Ring	G-'O'Ring	G-'O'Ring
105	33.4	34	31.7	21 x 1.65	22 x 2	6 x 1.5

PRB

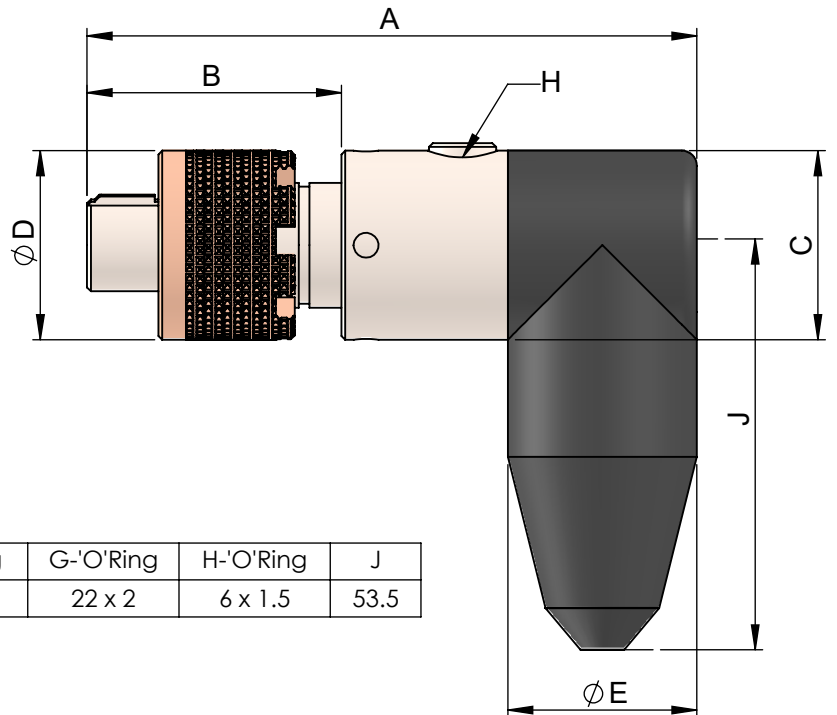
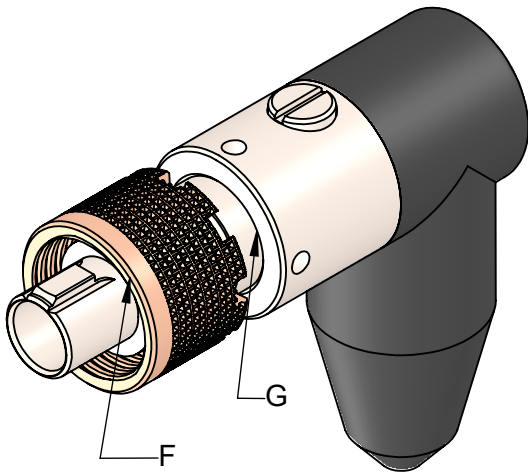

A	B	C	D	E	F-'O'Ring	G-'O'Ring	H-'O'Ring	J
100	33.4	34	31.7	34	21 x 1.65	22 x 2	6 x 1.5	53.5

Mould Sizes Are Indicative

Note: Step files for design purposes available from engineering @CRE-marine.com

## Assembled Dimensions 'B' Fibre Connector

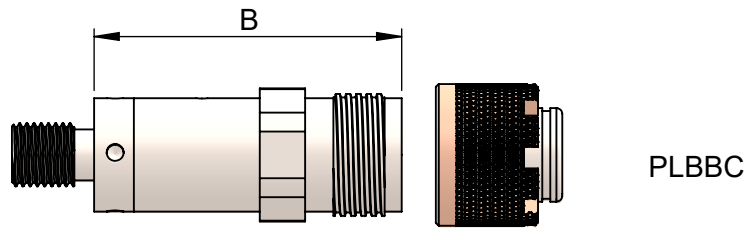

Assembled Dimension = 'B' + 9

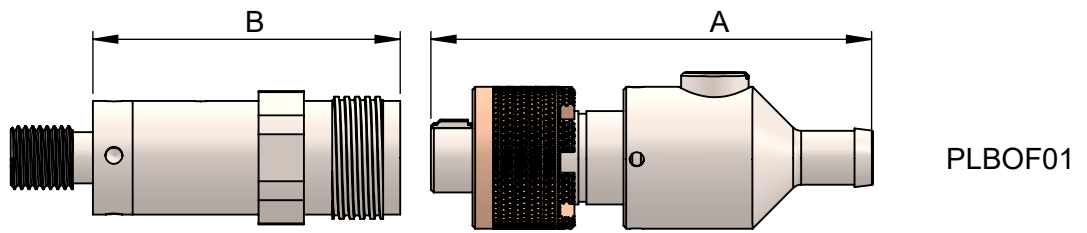

Assembled Dimension = 'B' + A - 22mm

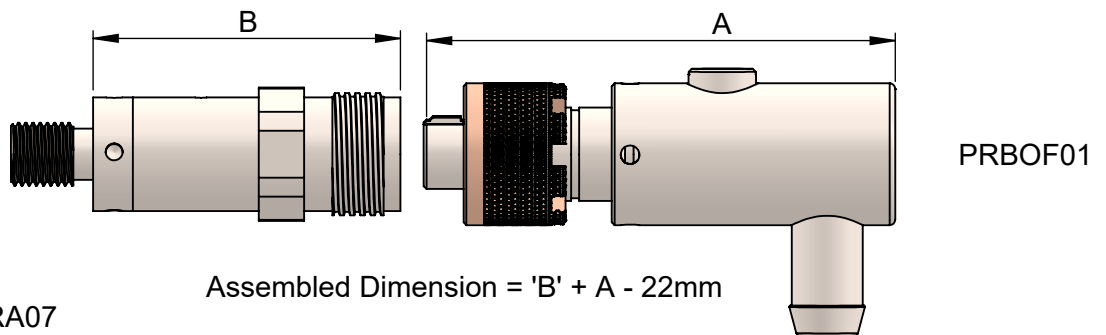

Assembled Dimension = 'B' + A - 22mm

BULKHEADS BRA01 - BRA07

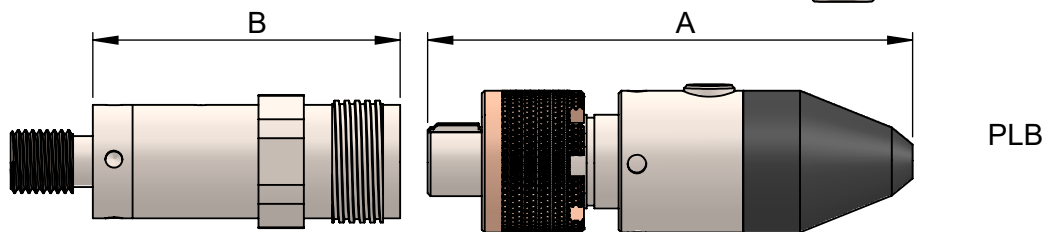

Assembled Dimension = 'B' + A - 22mm

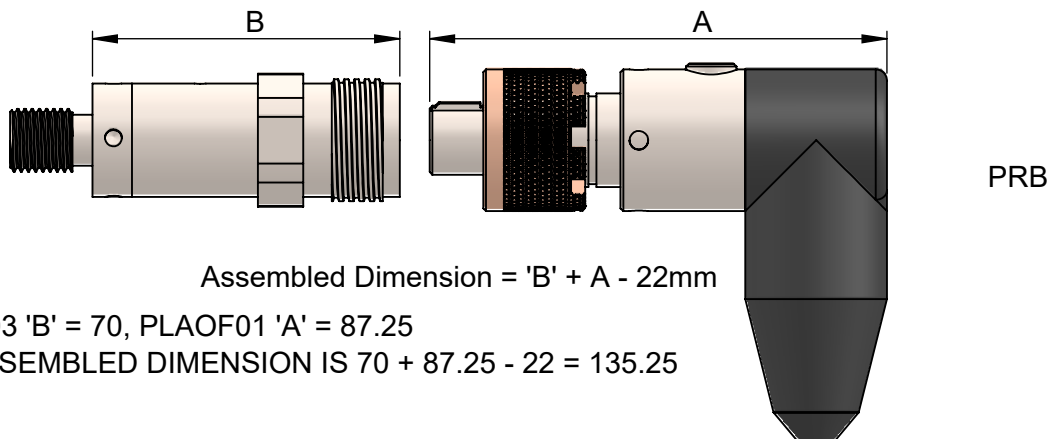

Assembled Dimension = 'B' + A - 22mm

EXAMPLE: BRA03 'B' = 70, PLAOF01 'A' = 87.25  
 THEREFORE ASSEMBLED DIMENSION IS 70 + 87.25 - 22 = 135.25

Mould Sizes Are Indicative

Note: Step files for design purposes available from engineering @CRE-marine.com

## Assembled Dimensions 'A' Fibre Connector

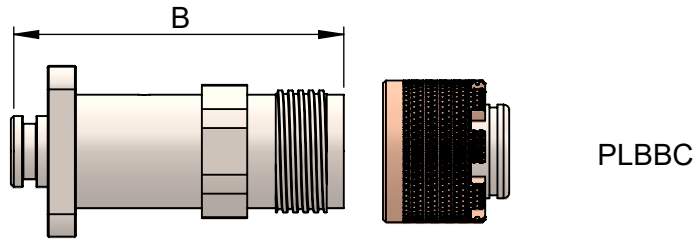

Assembled Dimension = 'B' + 9

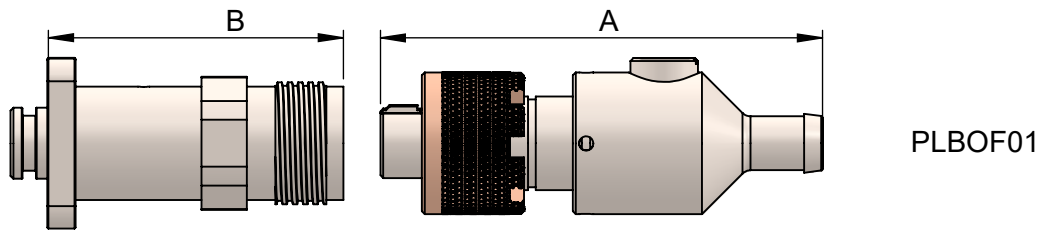

Assembled Dimension = 'B' + A - 22mm

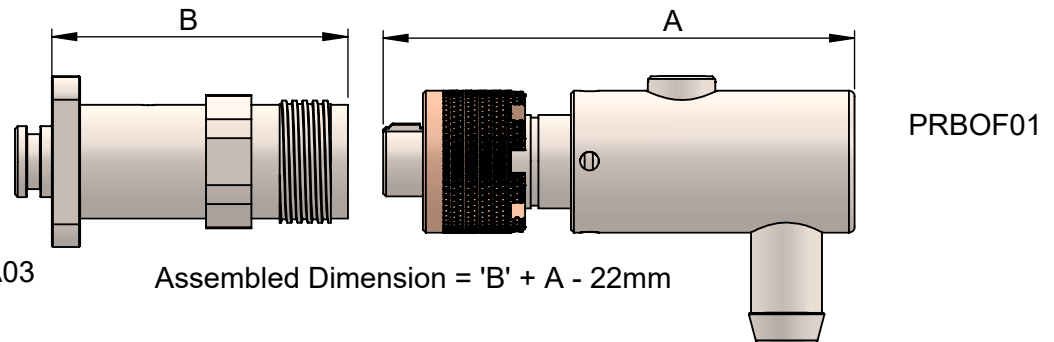

Assembled Dimension = 'B' + A - 22mm

BULKHEADS FRA01 - FRA03

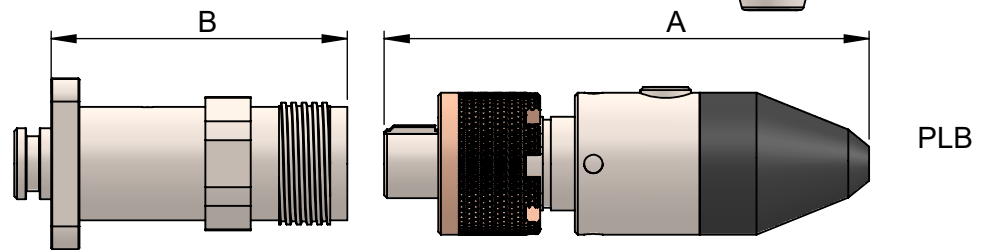

Assembled Dimension = 'B' + A - 22mm

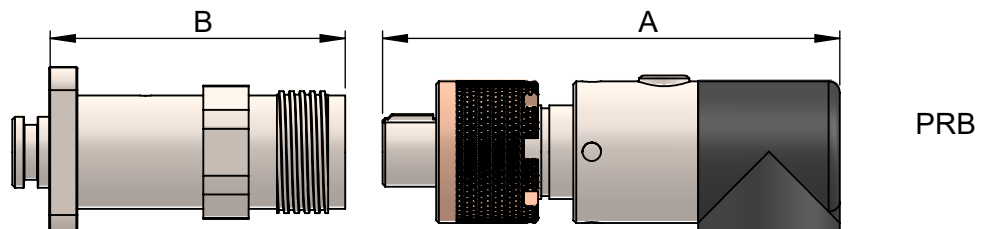

Assembled Dimension = 'B' + A - 22mm

EXAMPLE: BRA03 'B' = 70, PLAOF01 'A' = 87.25  
 THEREFORE ASSEMBLED DIMENSION IS 70 + 87.25 - 22 = 135.25

Mould Sizes Are Indicative

Note: Step files for design purposes available from engineering @CRE-marine.com

## FACE VIEW

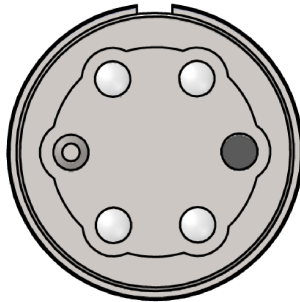

4 CHANNEL

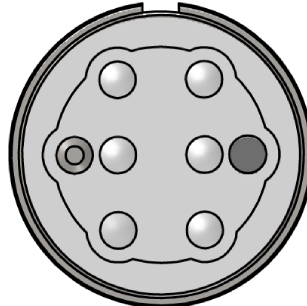

6 CHANNEL

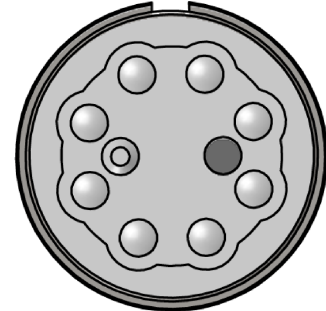

8 CHANNEL

FIBRE TYPE-----SM / MM  
 TAILS WITH CONNECTION TO SUIT-ST/SC ETC.

### Recommended Torque figures for threaded Bulkheads and Low Profile Interfaces manufactured in 316L Stainless Steel

THREAD	TORQUE N/m (Lubricated)	Torque Inch Pounds (Lubricated)
7/16-UNF	3-4	30-35
5/8-18 UNF	5-7	50-55
3/4-16 UNF	7-9	60-65
3/4-20 UNEF	7-9	60-65

The table above shows our recommended tightening torque values for the Size 'B' threaded Bulkheads and Low Profile Interfaces shown in these Datasheets.

We would recommend a small quantity of anti-seize lubricant such as Copaslip is used on the threads as a lubricant to aid the make up process.

CRE also supply Bulkheads manufactured from 6082-T6 Aluminium, Grade 5 Titanium

The same Torque figures can be applied for the Aluminium and Titanium materials.

Should you require any further information or advice then please contact CRE direct.