

techflo tp

Standard Twin Pumps

Standard Twin pumps are designed to boost the incoming hot and cold water supply to an individual shower, bath, shower mixer or mixer tap. Suitable for positive head applications only.

Techflo tp pumps require a flow of 0.8 l/min through the outlet to start.



Features

- Durable plastic construction
- 1.5 and 2.0 bar performance options
- Automatic switching
- Nitrile/carbon/silicon carbide seal
- 15 mm push-in flexible hoses
- G 3/4 threaded connections
- Pre-wired with 1.5 metre power cable
- Anti-vibration feet
- 1-year guarantee (subject to conditions)
- WRAS approved

Application

- Boost hot and cold water supplies equally
- Single function shower
- Bath/basin mixer tap

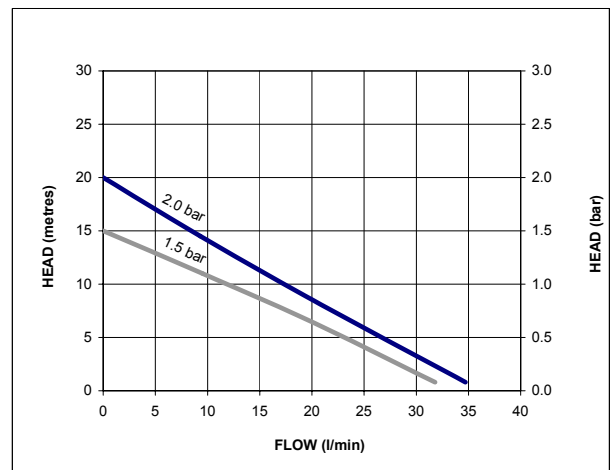

techflo tp

Pump Model		S1.5 bar Twin 49084	S2.0 bar Twin 49085
General	Guarantee	1 year	
	WRAS approved	1506334	
Features	Pump type	Centrifugal	
	Mechanical seal	Nitrile / Carbon / Silicon Carbide	
	Anti-vibration feet	✓	✓
	Inlet strainer(s)	✓	✓
	Flexible hoses	4	4
	Dry run protection	✓	✓
Materials	Pump body	Plastic	
	Impeller	Plastic	
Performance	Maximum head (closed valve)	1.5 bar	2.0 bar
	Performance @ 9 l/min	1.1 bar	1.5 bar
	Performance @ 18 l/min	0.7 bar	0.9 bar
	Maximum flow	32 l/min	35 l/min
	Maximum static inlet pressure	10 metres	
	Maximum working pressure*	300 kPa (3 bar)	
	Maximum ambient air temperature	40 °C	
	Min / Max water temperature**	Min 4 °C / Max 65 °C	
	Flow switch sensitivity (approx)	0.8 l/min	
Connections	Pump connections	G 3/4 male	
Flexible hoses	Connections	G 3/4 female x 15 mm push-in x 185 mm long (inlet) G 3/4 female x 15 mm push-in x 175 mm long (outlet)	
Motor	Type	Series wound, manual reset thermal trip	
	Duty rating	Intermittent (S3) 30 mins on/30 mins off @ 9 l/min***	
Electrical	Power supply / phase / frequency	230 V a.c. / 1 / 50 Hz	
	Current (full load)	1.2 Amps	1.5 Amps
	Power consumption	200 Watts	300 Watts
	Fuse rating	3 Amps	
	Power cable (pre-wired)	1.5 metres	
Physical	Enclosure protection	IPX2	
	Length	250 mm	
	Width	97 mm	
	Height (excluding hoses)	152 mm	
	Weight (including fittings)	2.6 Kg	

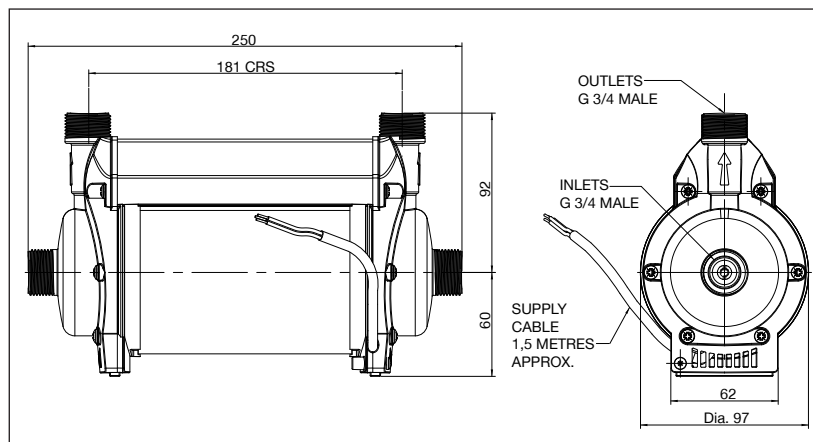

* The maximum pressure that can be applied to the pump under any installation conditions.

** A stored water temperature of 60 °C is considered sufficient to meet all normal requirements and will minimise deposition of scale in hard water areas.

*** Both heads pumping 4.5 l/min.

Stuart Turner Limited reserves the right to amend specifications without notice.